

TECHNICAL MANUAL

**OPERATOR'S, UNIT, DIRECT SUPPORT,
AND GENERAL SUPPORT MAINTENANCE MANUAL**

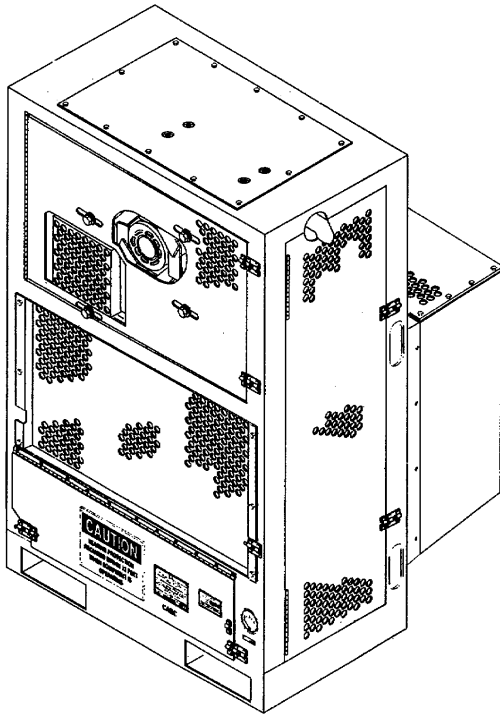

**REFRIGERATION UNIT, MECHANICAL,
5K BTU, DIESEL
MODEL F5000RD**

(4110-01-389-9181)

OPERATING INSTRUCTIONS	2-1
OPERATOR PREVENTIVE MAINTENANCE CHECKS AND SERVICES (PMCS)	2-6
UNIT MAINTENANCE INSTRUCTIONS	4-1
UNIT PREVENTIVE MAINTENANCE CHECKS AND SERVICES (PMCS)	4-8
UNIT TROUBLESHOOTING	4-34
DIRECT SUPPORT MAINTENANCE INSTRUCTIONS	5-1
GENERAL SUPPORT MAINTENANCE INSTRUCTIONS	6-1
MAINTENANCE ALLOCATION CHART	B-1

DISTRIBUTION STATEMENT A: Approved for public release; distribution is unlimited.

HEADQUARTERS, DEPARTMENT OF THE ARMY

10 October 1996

WARNING

- Exposed rotating parts are contained in the refrigeration unit. Personal injury can result if access doors are open when battery is connected.
- Muffler and engine may be hot to touch and can cause serious personal injury. Allow to cool before performing any maintenance functions.
- The fuel used in this refrigeration unit is highly explosive. Do not make or use open flame when performing maintenance. Flames and explosion could result in severe personal injury or death.
- The refrigeration unit engine produces dangerously high noise levels reaching 96 dB (A) at the service position. Approved hearing protection must be worn any time personnel are within 12 feet of an operating unit to avoid temporary or possibly permanent hearing damage.
- Dangerous chemical refrigerant under pressure is used in the refrigeration unit. Sudden and irreversible tissue damage can result from contact with liquid refrigerant. When exposed to high heat or flame, irritating, toxic, and corrosive gases may be released. Wear gloves and a face protector or safety glasses in any situation where skin or eye contact with refrigerant is possible. Do not allow refrigerant to come in contact with high heat or flame. All refrigerant must be discharged from the system and the entire system must be purged with dry nitrogen before beginning any brazing operation.
- Do not attempt any disassembly of refrigerant system components with a refrigerant charge in the system. Refrigerant will be sprayed out dangerously.
- Never introduce high discharge pressure into a refrigerant cylinder. This can cause the cylinder to rupture and injure personnel.
- Never pressurize refrigerant lines with oxygen, mixture with oil could cause an explosion.
- Nitrogen is an inert gas that can cause suffocation and must be discharged in a well ventilated area.
- The pressure in a nitrogen cylinder can exceed 2000 psi. A nitrogen pressure regulator should be used at all times to avoid personal injury.
- Acetone and methyl-ethyl ketone (MEK) are flammable and their vapors can be explosive. Repeated or prolonged skin contact or inhalation of vapors can be toxic. Use in a well ventilated area, wear gloves, and keep away from sparks or flame.
- Solder, brazing alloys, and flux contain materials which are hazardous to health. Avoid breathing vapors or fumes from soldering or brazing operations. Perform operations only in well-ventilated areas. Wash hands with soap and water after handling solder, brazing alloys, or flux. Wear thermal gloves and protective goggles or face shield to protect against burns.
- Compressor lubricating oil used in this refrigeration system is caustic. Wear gloves and a face protector or safety glasses in any situation where skin or eye contact is possible. If oil does contact skin, wash with soap and water.

**OPERATOR'S, UNIT, DIRECT SUPPORT AND
GENERAL SUPPORT MAINTENANCE MANUAL
FOR
REFRIGERATION UNIT, MECHANICAL,
5K BTU, DIESEL
MODEL F5000RD
4110-01-389-9181**

Reporting of Errors

REPORTING ERRORS AND RECOMMENDING IMPROVEMENTS

You can help improve this manual. If you find any mistakes or if you know of a way to improve these procedures, please let us know. Mail your letter, DA Form 2028 (Recommended Changes to Publications and Blank Forms), or DA Form 2028-2 located in the back of this manual direct to: Commander, U.S. Army Aviation and Troop Command, ATTN: AMSAT-I-MP, 4300 Goodfellow Blvd., St. Louis, MO 63120-1798. You may also submit your recommended changes by E-mail directly to <daf2028@st-louis-emh7.army.mil>. A reply will be furnished directly to you. Instructions for sending an electronic 2028 may be found at the back of this manual immediately proceeding the hard copy 2028.

DISTRIBUTION STATEMENT A: Approved for public release, distribution is unlimited.

TABLE OF CONTENTS

		Page
CHAPTER 1	INTRODUCTION	1-1
Section I	General Information	1-1
Section II	Equipment Description	1-3
Section III	Principles Of Operation.....	1-5
CHAPTER 2	OPERATING INSTRUCTIONS	2-1
Section I	Description And Use Of Operator's Controls And Indicators.	2-1
Section II	Preventive Maintenance Checks And Services (PMCS).....	2-6
Section III	Operation Under Usual Conditions	2-22
Section IV	Operation Under Unusual Conditions	2-30

TABLE OF CONTENTS - Continued

	Page
CHAPTER 3	OPERATOR MAINTENANCE INSTRUCTIONS 3-1
Section I	Lubrication 3-1
Section II	Troubleshooting Procedures..... 3-1
Section III	Operator's Maintenance Procedures 3-5
CHAPTER 4	UNIT MAINTENANCE INSTRUCTIONS 4-1
Section I	Repair Parts, Tools, Special Tools, Test, Measurement, And Diagnostic Equipment (TMDE), And Support Equipment 4-1
Section II	Service Upon Receipt 4-1
Section III	Unit Preventive Maintenance Checks And Services (PMCS) 4-8
Section IV	Troubleshooting Instructions 4-34
Section V	Unit Maintenance Instructions..... 4-38
Section VI	Preparation For Storage Or Shipment 4-165
CHAPTER 5	DIRECT SUPPORT MAINTENANCE INSTRUCTIONS 5-1
Section I	Direct Support Troubleshooting Instructions 5-1
Section II	Direct Support Maintenance Instructions..... 5-3
CHAPTER 6	GENERAL SUPPORT MAINTENANCE INSTRUCTIONS 6-1
APPENDIX A	REFERENCES A-1
APPENDIX B	MAINTENANCE ALLOCATION CHART B-1
Section I	Introduction B-1
Section II	Maintenance Allocation Chart For Refrigeration Unit..... B-5
Section III	Tool And Test Equipment Requirements For Refrigeration Unit B-11
Section IV	Remarks For Refrigeration Unit B-11
APPENDIX C	COMPONENTS OF END ITEM (COEI) AND BASIC ISSUE ITEMS (BII) LIST C-1
Section I	Introduction C-1
Section II	Components Of End Item C-1
Section III	Basic Issue Items List C-2
APPENDIX D	ADDITIONAL AUTHORIZATION LIST D-1
APPENDIX E	EXPENDABLE AND DURABLE ITEMS LIST E-1
Section I	Introduction..... E-1
Section II	Expendable And Durable Items List E-2

TABLE OF CONTENTS - Continued

		Page
APPENDIX F	ILLUSTRATED LIST OF MANUFACTURED ITEMS	F-1
Section I	F-1
Section II	F-1
APPENDIX G	MANDATORY REPLACEMENT PARTS.....	G-1

LIST OF ILLUSTRATIONS

Figure	Title	Page
1-0	Refrigeration Unit	1-0
1-1	Major Components	1-4
1-2	Operating/Electrical System	1-6
1-3	Electrical Schematic	1-7
1-4	Electrical Wiring Diagram	1-8
1-5	Refrigeration System.....	1-10
1-6	Refrigeration Schematic.....	1-11
1-7	Air Handling System.....	1-12
2-1	Operating Controls and Indicators.....	2-3
2-2	Fault Controls and Indicators	2-5
2-3	Operator PMCS Routing Diagram (Sheet 1 of 2)	2-8
2-3	Operator PMCS Routing Diagram (Sheet 2 of 2)	2-9
2-4	Operator Controls and Indicators (Sheet 1 of 2).....	2-23
2-4	Operator Controls and Indicators (Sheet 2 of 2).....	2-24
2-5	Decals and Instruction Plates (Sheet 1 of 2)	2-28
2-5	Decals and Instruction Plates (Sheet 2 of 2)	2-29
4-1	Wall Opening Dimensions	4-2
4-2	Installation	4-3
4-3	Unit Preparation	4-4
4-4	Refrigeration Valve Settings for Normal Operation	4-6
4-5	Defrost Timer Adjustment.....	4-7
4-6	Lubrication (Sheet 1 of 2).....	4-9
4-6	Lubrication (Sheet 2 of 2).....	4-10
4-7	Top Panel.....	4-38
4-8	Front Coil Guard Panel.....	4-40
4-9	Evaporator Cover Panel.....	4-41
4-10	Access Panel.....	4-42
4-11	Barrel Bolt	4-13
4-12	Unit Mounting Bolt Assembly	4-45
4-13	Wires Cables and Harnesses.....	4-47
4-14	Control Box Assembly	4-54

LIST OF ILLUSTRATIONS - Continued

Figure	Title	Page
4-15	Circuit Breaker	4-56
4-16	Lamp Assembly.....	4-58
4-17	Fuses	4-60
4-18	Control Relays.....	4-63
4-19	Time Delay Relay.....	4-64
4-20	Hourmeter.....	4-67
4-21	Ammeter	4-69
4-22	Toggle Switch.....	4-71
4-23	Defrost Timer	4-74
4-24	Remote Bulb Thermostat (Temperature Control).....	4-77
4-25	Engine Speed Switch	4-80
4-26	Control Transformer T1	4-82
4-27	Refrigeration Temperature Gage (Thermometer).....	4-85
4-28	Continuous Duty Solenoid.....	4-87
4-29	Battery	4-90
4-30	Temperature Switch	4-93
4-31	Push Switches	4-96
4-32	V-Belt	4-99
4-33	Engine Pulley.....	4-101
4-34	Idler Pulley	4-103
4-35	Condenser Fan.....	4-104
4-36	Evaporator Fan	4-106
4-37	Flange Bearing (Condenser Fan).....	4-107
4-38	Flange Bearing (Evaporator Fan)	4-109
4-39	Grease Fitting Extension.....	4-110
4-40	Fan Clutch	4-113
4-41	Solenoid Valve (Liquid Line)	4-115
4-42	Solenoid Valve (Defrost Line)	4-118
4-43	Oil Filter	4-120
4-44	Air Cleaner.....	4-122
4-45	Muffler	4-124
4-46	Engine Oil Pressure Switch.....	4-125
4-47	Engine Temperature Switch	4-127
4-48	Fuel Solenoid.....	4-128
4-49	Starting Motor.....	4-130
4-50	Fuel Filter.....	4-133
4-51	Voltage Regulator.....	4-134
4-52	Alternator Test Point.....	4-135
4-53	Glow Plug.....	4-137
4-54	Engine Drain Hose	4-139
4-55	Engine	4-141
4-56	Fuel Supply Hoses (Sheet 1 of 2)	4-145
4-56	Fuel Supply Hoses (Sheet 2 of 2)	4-146
4-57	Fuel Return Hoses	4-151
4-58	In-line Fuel Filter	4-154
4-59	Fuel Gage	4-156

LIST OF ILLUSTRATIONS - Continued

Figure	Title	Page
4-60	Sending Unit	4-158
4-61	Fuel Tank	4-160
4-62	Gasket (Heat Shield)	4-164
4-63	Refrigeration System Pump Down	4-166
5-1	Control Box Cover Assembly.....	5-4
5-2	Access Panel	5-5
5-3	Control Panel	5-7
5-4	Battery Shield.....	5-9
5-5	Compressor Pulley	5-10
5-6	Fan Drive Shaft	5-11
5-7	Service Manifold Installation	5-14
5-8	Discharging Refrigerant.....	5-15
5-9	Nitrogen Tank Connection	5-17
5-10	Evacuation of Refrigerant System	5-24
5-11	Refrigerant Charging (Total System)	5-26
5-12	Refrigerant Charging (Partial System /Small Quantity Charge)	5-28
5-13	Dehydrator	5-33
5-14	Compound Gage	5-35
5-15	Pressure Gage	5-37
5-16	Strainer	5-38
5-17	Isolation Valves.....	5-39
5-18	Receiver.....	5-42
5-19	Condenser Coil	5-43
5-20	Pressure Regulator Valve.....	5-45
5-21	Pressure Regulator Valve.....	5-47
5-22	Check Valve	5-48
5-23	Metal Hose Assembly	5-49
5-24	Metal Hose Assembly	5-50
5-25	Accumulator.....	5-52
5-26	Solenoid Valve (Liquid Line)	5-54
5-27	Solenoid Valve (Defrost Line)	5-55
5-28	Stop Valve	5-57
5-29	Stop Valve	5-59
5-30	Sight Indicator	5-60
5-31	Differential Oil Pressure Switch	5-62
5-32	Dual Pressure Control Switch	5-64
5-33	Heat Exchanger	5-66
5-34	Expansion Valve	5-67
5-35	Evaporator Coil	5-69
5-36	Compressor.....	5-72
5-37	Tubing And Fittings	5-80
5-38	Nozzle.....	5-82
5-39	Fuel Injection Pumps	5-85

LIST OF ILLUSTRATIONS - Continued

Figure	Title	Page
5-40	Fuel Pump.....	5-90
5-41	Cylinder Head	5-92
5-42	Engine Oil Pump	5-95
5-43	Flywheel	5-97
5-44	Alternator	5-99
5-45	Engine and Compressor Base.....	5-101
5-46	Left and Right Side Doors.....	5-103
5-47	Front Door	5-105
C-1	Basic Issue Items	C-2
F-1	Tube, Copper Straight, Various	F-4
F-2	Tubing-Copper, Straight Flared, Various.....	F-4
F-3	Gasket, Various.....	F-5
F-4	Chain, Sash, Part Number 12290-8- 8000.....	F-5
F-5	Insulation, Sound and Temperature, Part Number 148K0000-1/204.....	F-6
F-6	Insulation Sleeving	F-6
F-7	Insulation Tubing, Part Number 148K0000-1/233.....	F-7
F-8	Gasket, Control Box, Top, Part Number 148K0018.....	F-7
F-9	Webbing Fabric, Part Number 148K0093-3	F-7
F-10	Gasket, Control Box Cover	F-8
F-11	Gasket, Control Cover, Part Number 148K0113-13.....	F-8
F-12	Gasket, Top/Bottom, Part Number 148K0143	F-9
F-13	Gasket, Right/Left, Part Number 148K0144.....	F-9
F-14	Tube, Coil To Heat Exchanger, Part Number 148K0168.....	F-10
F-15	Tube expansion, Valve To Heat Exchanger, Part Number 148K0169-1/T.....	F-10
F-16	Tube, Expansion Valve Bypass, Part Number 148K0171.....	F-11
F-17	Tube, 0.375 Tee To Defrost Coil, Part Number 148K0173.....	F-11
F-18	Tube, Heat Exchanger to 0.375 Elbow, Part Number 148K0174.....	F-12
F-19	Tube, Condenser Outlet, Part Number 148K0221.....	F-12
F-20	Tube, Receiver Inlet, Part Number 148K0222-1/T.....	F-13
F-21	Tube, Receiver To Filter Drier, Part Number 148K0223-1-T	F-14
F-22	Tube, Hand Valve To Solenoid N. C., Part Number 148K0224-1/T	F-15
F-23	Tube, Solenoid N.C to Sight Glass, Part Number 148K0225-1/T.....	F-16
F-24	Tube, Sight Glass To Elbow, Part Number 148K0226-1 /T.....	F-17
F-25	Tube, Compressor Discharge, Part Number 148K0227.....	F-18
F-26	Tube, Isolator (Discharge) to Reducer Elbow, Part Number 148K0228.....	F-18
F-27	Tube, Strainer Hand Valve, Part Number 148K0229.....	F-19
F-28	Tube, Strainer to Solenoid N.O., Part Number 148K0230-1/T	F-20
F-29	Tube, Solenoid N.O. to Elbow, Part Number 149K0231-1/T.....	F-21
F-30	Tube, Isolator (Suction) To CPR Valve, Part Number 148K0232	F-22
F-31	Tube, Discharge Pressure Regulator to Elbow, Part Number 148K0233.....	F-22
F-32	Tube, DPR Valve To Street, Part Number 148K0234.....	F-23
F-33	Gasket, Horizontal, Part Number 148K0245	F-23
F-34	Hose, Drain, Part Number 150K0165.....	F-24

LIST OF ILLUSTRATIONS - Continued

Figure	Title	Page
F-35	Braid, Wire, Tubular, Part Number 150K0185-1/1 and 150K0201-1/1	F-24
F-36	Capillary Lines, Part Number 150K0206-3/3 & -5/3.....	F-25
F-37	Contact Cradle, Sensing Bulb, Part Number 152K0194	F-25
F-38	Loom-1/2 I.D. Part Number 51206-13, -25, -30, and -36	F-26
F-39	Tape, Adhesive, Part Number 8337032-4	F-26

LIST OF TABLES

Table	Title	Page
2-1	Operator Preventive Maintenance Checks and Services for Model F5000RD	2-10
4-1	Unit Preventive Maintenance Checks and Services for Model F5000RD	4-12
4-2	200 Hour Mandatory Replacement Parts	4-33
4-3	Semi-Annually Mandatory Replacement Parts	4-33
4-4	Wire List.....	4-49
5-1	Pressure Temperature Relationship of Saturated Refrigerant R-134a	5-30
5-2	Nominal Operating Pressure At Suction And Discharge Shut Off Valves	5-31

HOW TO USE THIS MANUAL

Be sure to read all Warnings before using this equipment.

This manual contains instructions for operation and maintenance of the Refrigeration Unit.

The front cover index of this manual lists the areas of the manual used most often and guides you to those sections. Follow the black mark on the cover index edge through the pages to the edge mark on the section you want. The subjects on the front cover index are also boxed in the table of contents. A detailed alphabetical index is located at the back of the manual.

Chapter 1- Introduces you to the equipment and gives you information such as weight and dimensions used and general theory of operation including principles of operation.

Chapter 2- Provides the operator with information necessary to identify and service the equipment. Operating instructions for usual and unusual conditions.

Chapter 3- Provides operator lubrication tasks, and troubleshooting procedures for identifying common equipment malfunctions. Provides maintenance procedures for performing operator maintenance tasks.

Chapter 4- Provides unit maintenance personnel with procedures for lubrication and service upon receipt of equipment and instructions for performing repairs on equipment as authorized by the maintenance allocation chart.

Chapter 5- Provides direct support maintenance personnel with instructions for performing repairs on equipment as authorized by the maintenance allocation chart.

Chapter 6- Provides general support maintenance personnel with instructions for performing repairs on equipment as authorized by the maintenance allocation chart.

Appendix A -Provides a list of frequently used forms and publications referenced or used in this manual.

Appendix B -The maintenance allocation chart identifies repairable components and the maintenance level authorized to perform the repairs.

Appendix C- List of components of end item and basic issue items to help you inventory the equipment.

Appendix D- Lists additional items that are authorized for the support of the refrigeration unit.

Appendix E- Lists expendable and durable items needed to operate and maintain the refrigeration unit.

Appendix F- Provides you with instructions for making items authorized to be manufactured or fabricated at unit, direct support or general support maintenance.

Appendix G- Lists all mandatory replacement parts.

Alphabetical Index Lists subject matter contained in manual in alphabetical order with the paragraph number.

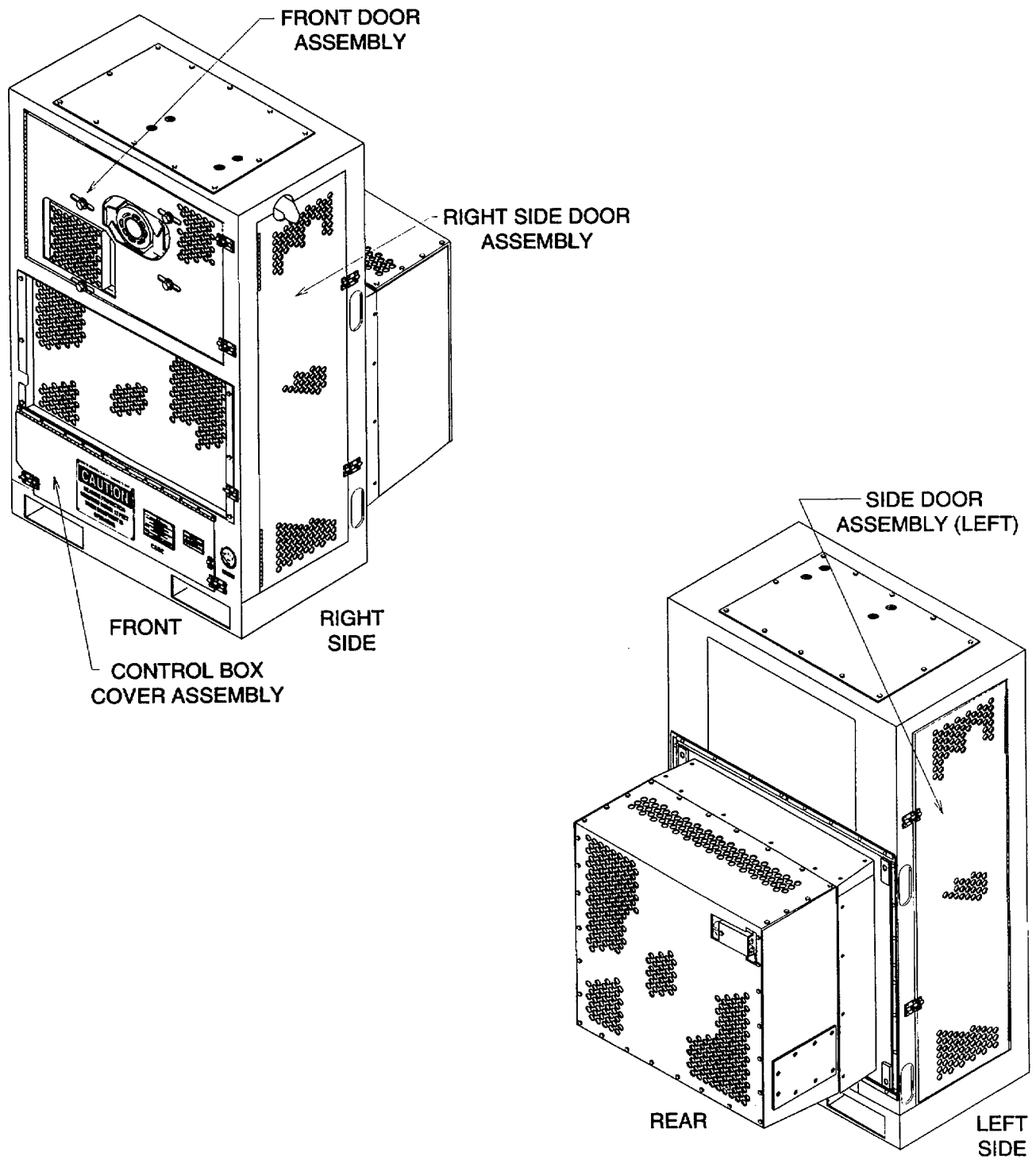

Figure 1-0. Refrigeration Unit

CHAPTER 1

INTRODUCTION

SECTION I GENERAL INFORMATION

1-1. SCOPE.

- a. Type of Manual. Operator's, Unit, Direct Support and General Support Maintenance Manual.
- b. Model Number and Equipment Name. The Model F5000RD, Mechanical, Diesel engine driven, 5,000 Btu per hour Refrigeration Unit.
- c. Purpose of Equipment. The portable, field use refrigeration unit is intended to be used with a 150 cubic foot refrigerator covered by MIL-R-12571 and a 70 cubic foot refrigerator covered by MIL-R-43024.

1-2. MAINTENANCE FORMS. RECORDS AND REPORTS.

Department of the Army forms and procedures used for equipment maintenance will be those prescribed by DA Pam 738-750, The Army Maintenance Management System.

1-3. DESTRUCTION OF ARMY MATERIAL TO PREVENT ENEMY USE.

Refer to TM 750-244-3 for specific instructions on the destruction of army material to prevent enemy use.

1-4. PREPARATION FOR STORAGE OR SHIPMENT.

Refer to Chapter 4 for specific information under the same heading.

1-5. QUALITY ASSURANCE.

Requirement for specific quality assurance steps are not applicable to this equipment.

1-6. OFFICIAL NOMENCLATURE, NAMES AND DESIGNATIONS.

The following listings include the nomenclature cross-reference list, list of abbreviations, and explanation of terms (glossary) used in this manual.

Nomenclature Cross-Reference List. A shortened nomenclature is used in this manual to make procedures easier for you to read. A cross-reference between the shortened nomenclature and the official nomenclature is shown in the following table.

<u>Manual Nomenclature</u>	<u>Official Nomenclature</u>
Refrigeration Unit	Refrigeration Unit, Mechanical, 5K btu, Diesel, Model F5000RD
Refrigerator Enclosure	Prefabricated Panel Type Refrigerator

1-7. REPORTING EQUIPMENT IMPROVEMENT RECOMMENDATIONS (EIR).

If your Diesel Refrigeration Unit needs improvement, let us know. Send us an EIR. You, the user, are the only one who can tell us what you don't like about your equipment. Let us know why you don't like the design or performance. Put it on an SF 368 (Product Quality Deficiency Report). Mail it to:

Commander
 U.S. Army Aviation and Troop Command
 ATTN: AMSAT-I-MDO
 4300 Goodfellow Blvd.
 St. Louis, MO 63120-1798

1-8. WARRANTY INFORMATION.

Refer to TB 9-4110-255-24 for specific warranty information.

1-9. CORROSION PREVENTION AND CONTROL.

a. Corrosion Prevention and Control (CPC) of Army material is a continuing concern. It is important that any corrosion problems with this item be reported so that the problem can be corrected and improvements can be made to prevent the problem in future items.

b. While corrosion is typically associated with rusting of metals, it can also include deterioration of other materials, such as rubber and plastic. Unusual cracking, softening, swelling, or breaking of these materials may be a corrosion problem.

c. If a corrosion problem is identified, it can be reported using Standard Form 368, Product Quality Deficiency Report. Use of keywords such as "corrosion," "rust," "deterioration," or "cracking" will ensure that the information is identified as a CPC problem. The form should be submitted to the address specified in DA Pam 738-750.

SECTION II EQUIPMENT DESCRIPTION

1-10. EQUIPMENT CHARACTERISTICS, CAPABILITIES AND FEATURES.

a. Characteristics. The Keco Model F5000RD, is a self-contained, diesel engine driven, panel-mounted refrigeration unit used with a prefabricated panel type refrigerator. It can be used under adverse climatic and operating conditions without added protection from the elements.

b. Capabilities. The unit is capable of starting and operating in ambient temperature of 0° F to 1250 F (-17° C to 520 C) and to automatically maintain a refrigerator temperature of 0° F and 35° F (-170 C and 2° C).

c. Features. The portion of the condensing unit exposed to weather is capable of operating in rainfall of three inches per hour without functional damage or impaired operation. This unit is designed to use R-134a refrigerant.

1-11. LOCATION AND DESCRIPTION OF MAJOR COMPONENTS.

See figure 1-1.

- 1 CONTROL BOXASSEMBLY. Houses the automatic and manual engine and electrical control components as well as system monitoring gauges.
- 2 EVAPORATOR COIL. Absorbs heat from the air being circulated through the refrigerator enclosure causing the low pressure liquid refrigerant in the coil to evaporate.
- 3 COMPRESSOR. Moves the refrigerant through the refrigeration system by raising the pressure of the incoming gas from the evaporator coil and discharging it as a high pressure gas.
- 4 CONDENSER COIL. Releases heat from the high pressure gas coming from the compressor causing the gas to condense into a high pressure liquid.
- 5 DIESEL ENGINE. Drives the compressor and air handling components.
- 6 EVAPORATOR FAN. Circulates air through the refrigerator and across the evaporator coil.
- 7 CONDENSER FAN. Circulates ambient, outside air across the condenser coil.
- 8 DUAL PRESSURE CONTROL SWITCH. Provides over/under pressure protection for the refrigeration system. The switch has a manual reset for over pressure conditions.
- 9 DIFFERENTIAL OIL PRESSURE SWITCH. Provides protection against loss of lubricating oil in the compressor. The switch has a manual reset for low oil conditions.

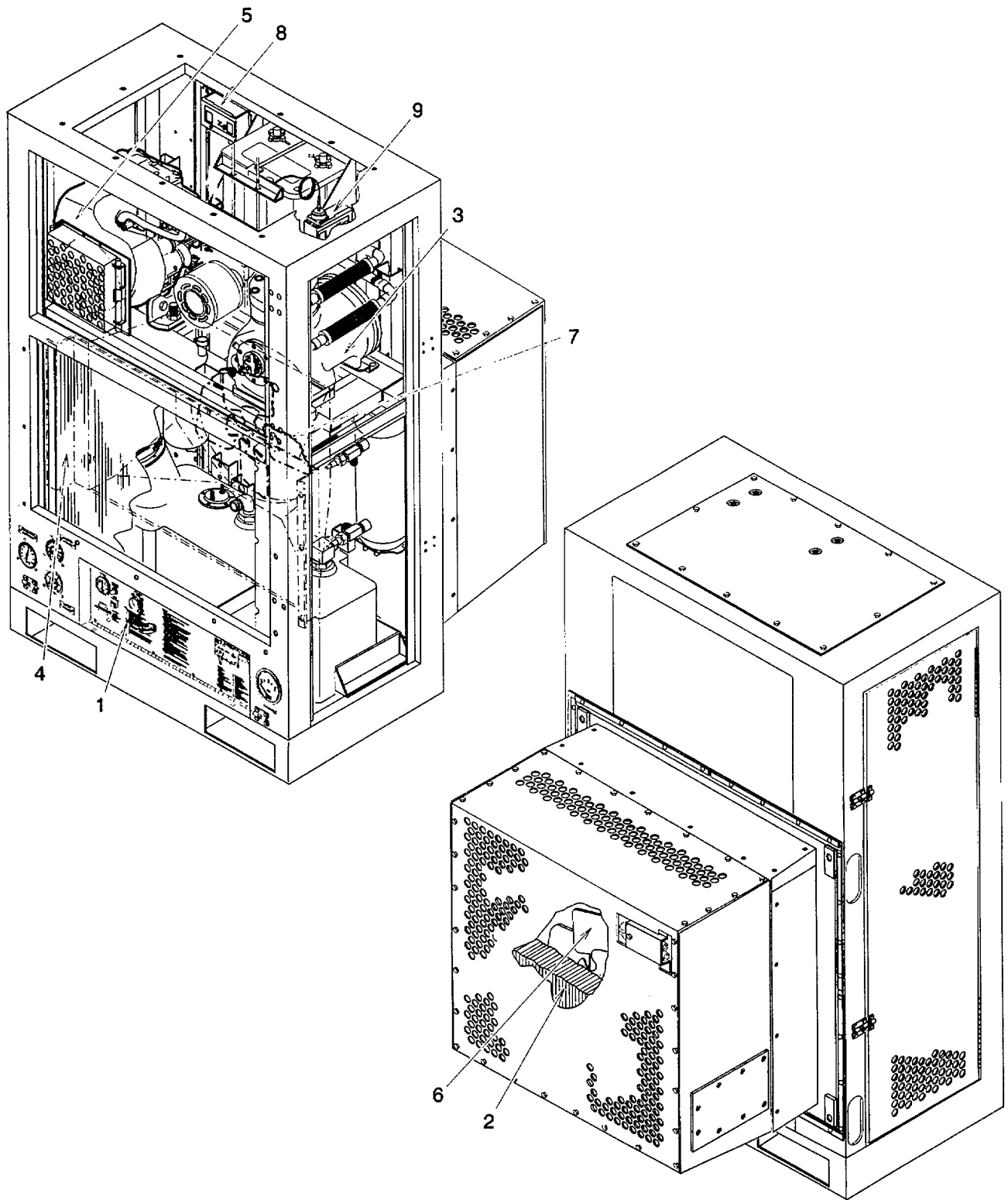

Figure 1-1. Major Components

1-12. EQUIPMENT DATA.

WEIGHTS AND DIMENSIONS

Weight	- 800 lb.(363 Kg)
Width	35.0 in. (88.9 cm)
Height.....	56.5 in. (143.5 cm)
Depth	35.1 in. (89.2 cm)

PERFORMANCE

Cooling Capacity

0° F (-18° C)	5,000 btuh
35° F (2° C)	7,500 btuh

ENGINE CHARACTERISTICS

Horsepower.....	5.4
Number of Cylinders	1
RPM	3,000

FLUID CAPACITIES

Refrigerant R134a.....	10 lb. (4.5 Kg)
Compressor Lubricating Oil.....	5.5 pt. (2.6 l)
Fuel Tank	9 gal. (34l)
Engine Lubricating Oil	85 qt. (80.1)

SECTION III PRINCIPLES OF OPERATION

1-13. OPERATING SYSTEM.

The refrigeration unit is self-contained, using a diesel engine to operate. Fuel for the engine is supplied from a self contained fuel tank. The engine is started using an electric starter motor powered by a battery in the refrigeration unit. The engine contains an alternator which is controlled by a voltage regulator to provide system power and charge the battery. The engine drives the refrigerant compressor and air handling equipment. The control box assembly houses various automatic and manual components which control the engine/compressor and air handling system. The compressor causes refrigerant flow through the refrigeration system and the air handling system circulates air through the refrigeration unit and refrigerator enclosure.

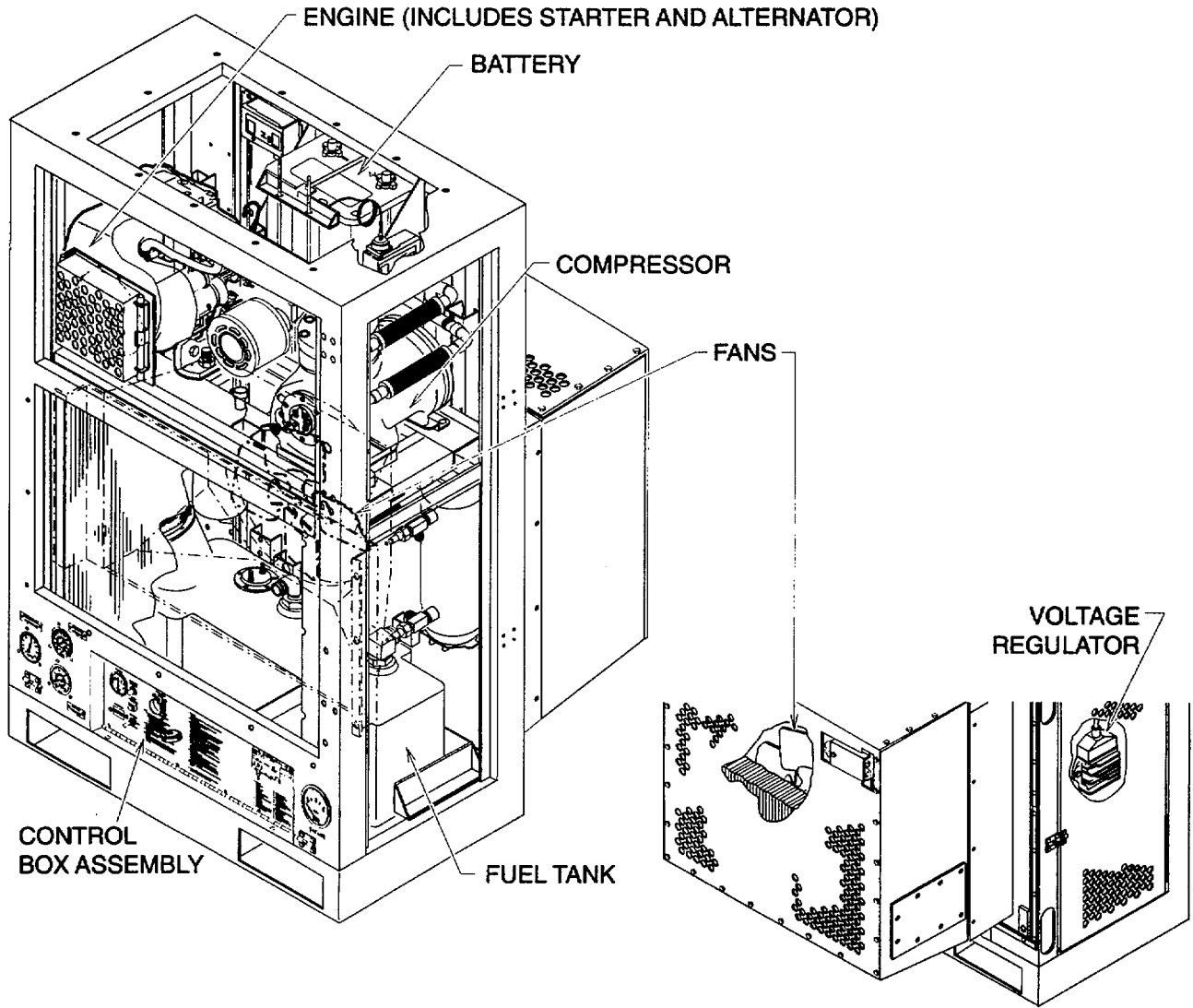
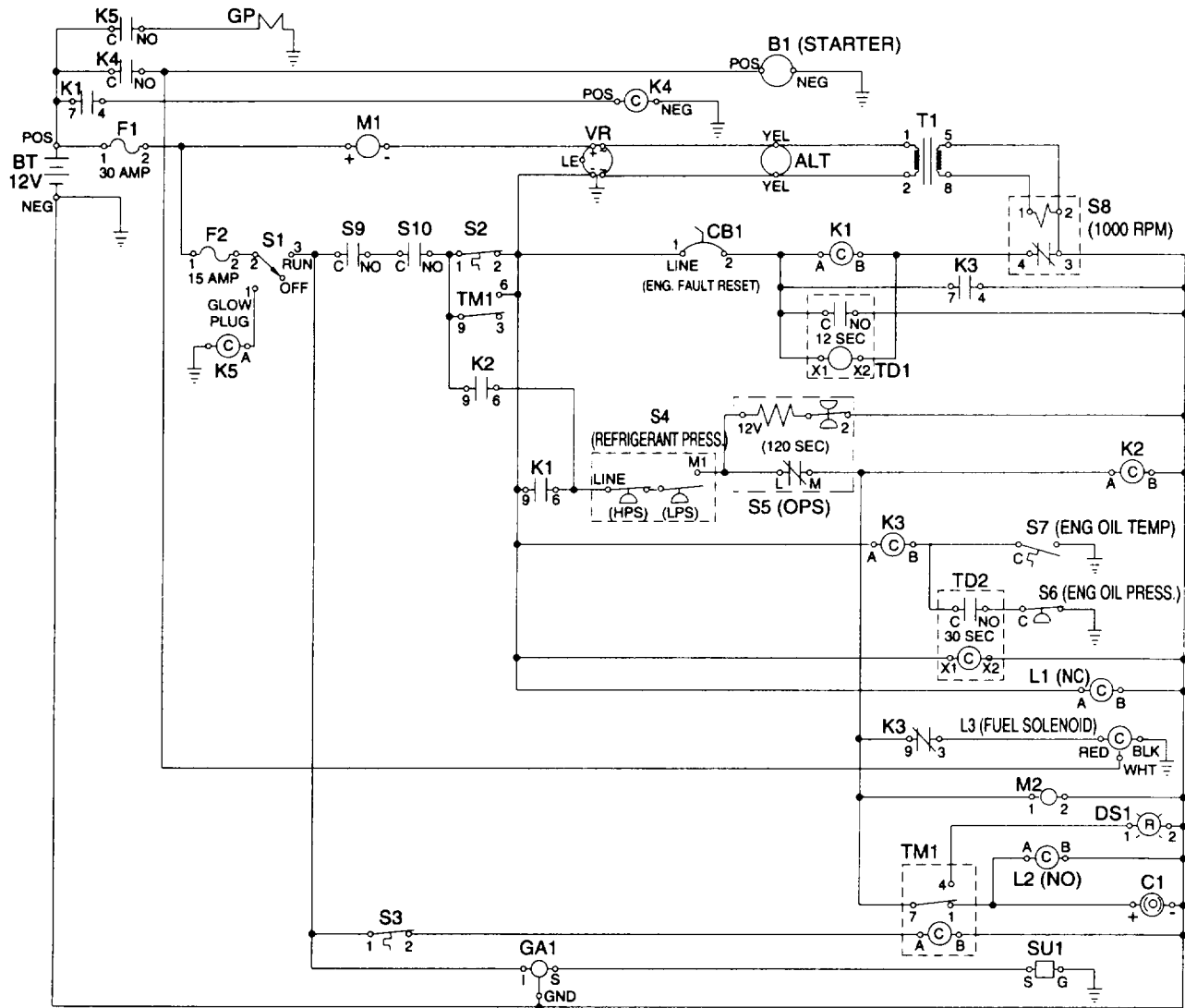
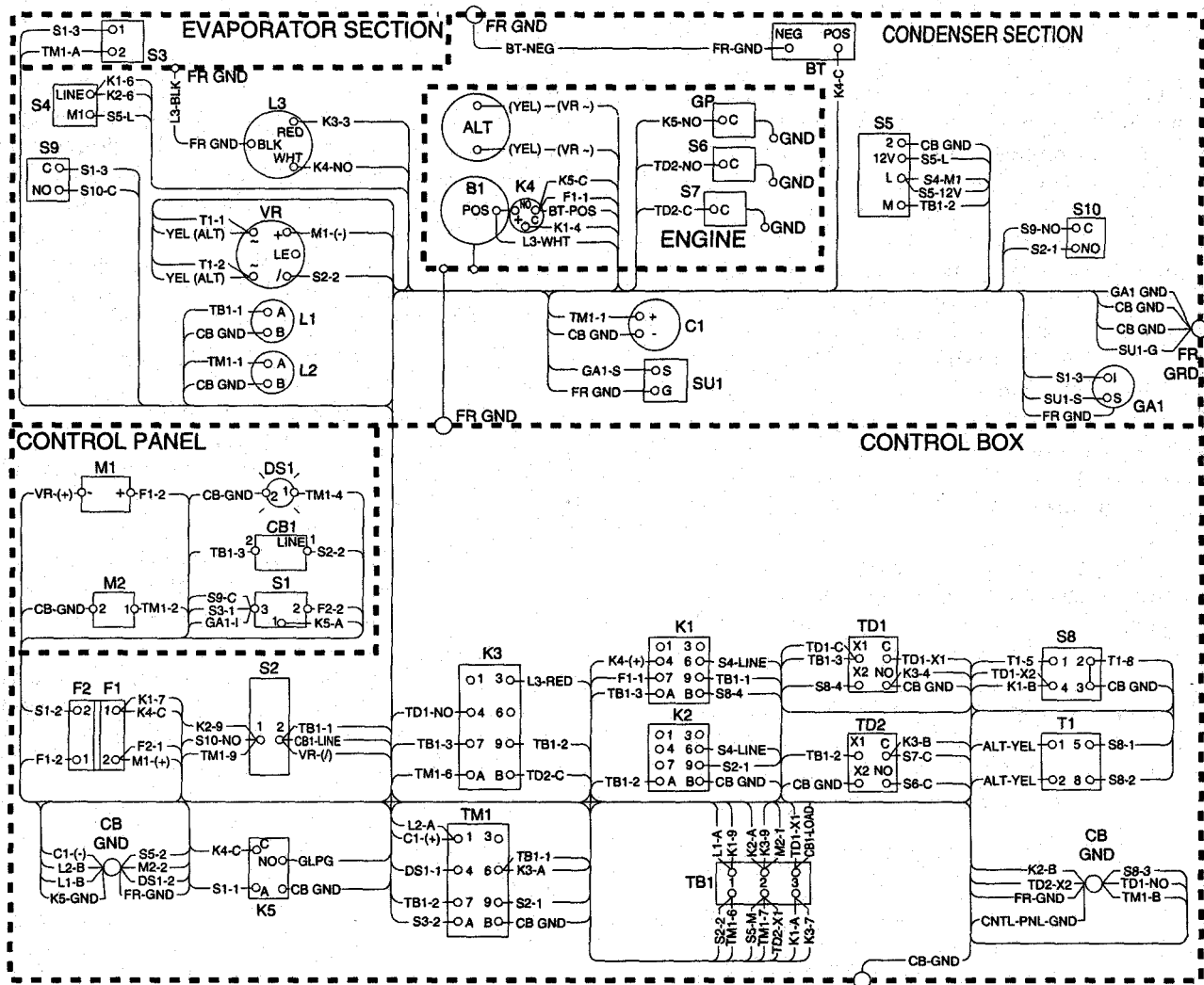

Figure 1-2. Operating/Electrical System



LEGEND		LEGEND	
ITEM	DESCRIPTION	ITEM	DESCRIPTION
ALT	ALTERNATOR (12V, 280W)	M1	AMMETER
B1	STARTER (12V, 1.3 KW)	M2	HOURMETER
BT	BATTERY, 12V	S1	SWITCH, TOGGLE (START/RUN-OFF-GLOWPLUG)
C1	CLUTCH, FAN DRIVE	S2	THERMOSTAT, REMOTE BULB
CB1	CIRCUIT BREAKER (ENGINE FAULT RESET)	S3	SWITCH, DEFROST TERMINATION
DS1	LIGHT, INDICATOR (DEFROST)	S4	SWITCH, REFRIGERANT PRESSURE
F1	FUSE (30 AMP)	S5	SWITCH, REFRIGERANT OIL PRESSURE
F2	FUSE (15 AMP)	S6	SWITCH, ENGINE OIL PRESSURE
GA1	GAUGE, FUEL LEVEL	S7	SWITCH, ENGINE TEMPERATURE
GP	GLOW PLUG	S8	SWITCH, ENGINE SPEED
K1	RELAY, STARTER SOLENOID	S9,10	SWITCH, PUSHBUTTON (DOOR)
K2,3	RELAY, CONTROL	SU1	SENDING UNIT, FUEL LEVEL
K4	SOLENOID, STARTER	T1	TRANSFORMER, CONTROL
K5	SOLENOID, CONTINUOUS DUTY	TD1	RELAY TIME DELAY (STARTER)
L1	SOLENOID VALVE, NC (LIQUID LINE)	TD2	RELAY TIME DELAY (ENGINE OIL PRESSURE)
L2	SOLENOID VALVE, NO (DEFROST/EQUALIZER)	TM1	TIMER, DEFROST
L3	SOLENOID, FUEL SHUTOFF (12V)	VR	VOLTAGE REGULATOR

Figure 1-3. Electrical Schematic



LEGEND

ITEM	DESCRIPTION	ITEM	DESCRIPTION
ALT	ALTERNATOR (12V, 280W)	M2	HOURMETER
B1	STARTER (12V, 1.3 KW)	S1	SWITCH, TOGGLE (START/RUN-OFF-GLOWPLUG)
BT	BATTERY, 12V	S2	THERMOSTAT, REMOTE BULB
C1	CLUTCH, FAN DRIVE	S3	SWITCH, DEFROST TERMINATION
CB1	CIRCUIT BREAKER (ENGINE FAULT RESET)	S4	SWITCH, REFRIGERANT PRESSURE
DS1	LIGHT, INDICATOR (DEFROST IN PROGRESS)	S5	SWITCH, REFRIGERANT OIL PRESSURE
F1	FUSE (30 AMP)	S6	SWITCH, ENGINE OIL PRESSURE
F2	FUSE (15 AMP)	S7	SWITCH, ENGINE TEMPERATURE
GA1	GAUGE, FUEL LEVEL	S8	SWITCH, ENGINE SPEED
GP	GLOW PLUG	S9,10	SWITCH, PUSHBUTTON (DOOR)
K1	RELAY, STARTER SOLENOID	SU1	SENDING UNIT, FUEL LEVEL
K2,3	RELAY, CONTROL	T1	TRANSFORMER, CONTROL
K4	SOLENOID, STARTER	TB1	TERMINAL BOARD
K5	SOLENOID CONTINUOUS DUTY	TD1	RELAY TIME DELAY (STARTER)
L1	SOLENOID VALVE, NC (LIQUID LINE)	TD2	RELAY TIME DELAY (ENGINE OIL PRESSURE)
L2	SOLENOID VALVE, NO (DEFROST/EQUALIZER)	TM1	TIMER, DEFROST
L3	SOLENOID, FUEL SHUTOFF (12V)	VR	VOLTAGE REGULATOR
M1	AMMETER		

Figure 1-4. Electrical Wiring Diagram

1-14. REFRIGERATION SYSTEM.

a. Cooling Cycle. Heat is absorbed from the refrigerator enclosure and released to the outside ambient air using refrigerant flowing through the refrigeration system. The compressor moves the refrigerant through the refrigeration system by raising the pressure of the incoming gas from the evaporator coil (evaporator) and discharging it as a high pressure gas. The high pressure gas passes through the condenser coil (condenser) where heat is released to the outside ambient air causing the high pressure gas to condense to a high pressure liquid. The high pressure liquid, which may contain some gas, is collected in the receiver. The receiver contains a dip tube that allows only liquid to flow from it. The high pressure liquid passes through the heat exchanger where it is cooled by low pressure gas returning to the compressor. The high pressure liquid passes through the expansion valve (thermostatic expansion valve) which causes a pressure drop and automatically meters the amount of liquid passing through it. The rapid drop in pressure causes the liquid to cool. The cool, low pressure liquid passes through the evaporator coil where heat is absorbed from the refrigerator enclosure air causing the low pressure liquid to evaporate to a low pressure gas. The low pressure gas passes through the heat exchanger where it absorbs heat from the high pressure liquid going into the expansion valve. The low pressure gas, which may contain some liquid, is collected in the accumulator (suction accumulator). The accumulator separates the low pressure gas from any liquid and allows only gas to flow from it. The low pressure gas returns to the compressor to begin the cycle again.

b. Defrost Cycle. By lowering the temperature in the refrigerator enclosure to a temperature below freezing, any moisture that accumulates on the evaporator coil will freeze and prevent proper air circulation through the coil. The defrost cycle is automatically controlled by a temperature sensor and electronic timer in the electrical system. The evaporator coil is defrosted when high pressure gas is sent from the compressor directly into the coil. To prevent water from freezing in the evaporator coil drip pan, the warm high pressure gas tubing is routed through the drain hole in the drip pan. The high pressure gas tubing then serpentine across the bottom of the drip pan before entering the coil. The high pressure gas is then returned to the compressor to begin the cycle again. The defrost cycle will continue until either the temperature sensor or electronic timer terminates it.

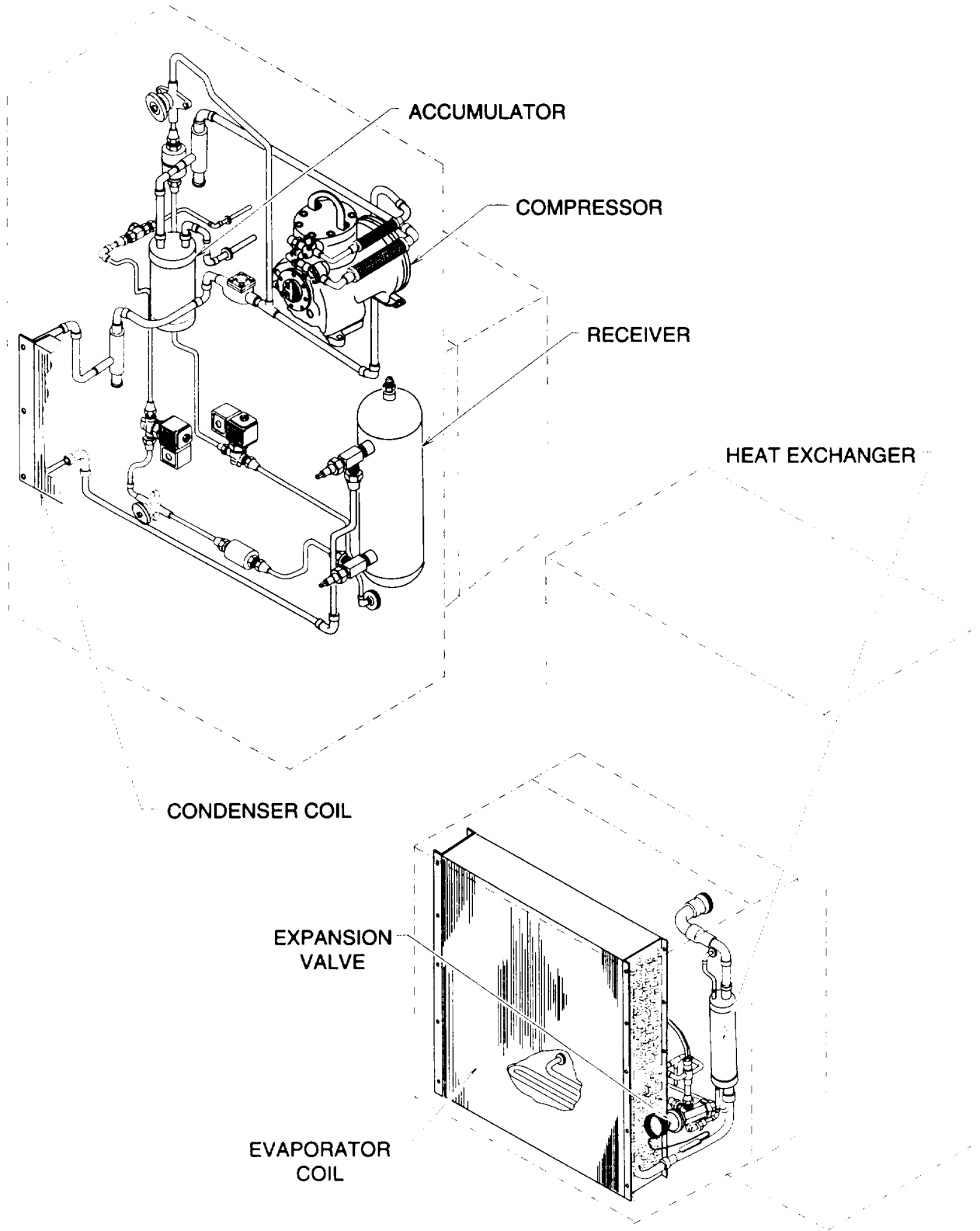
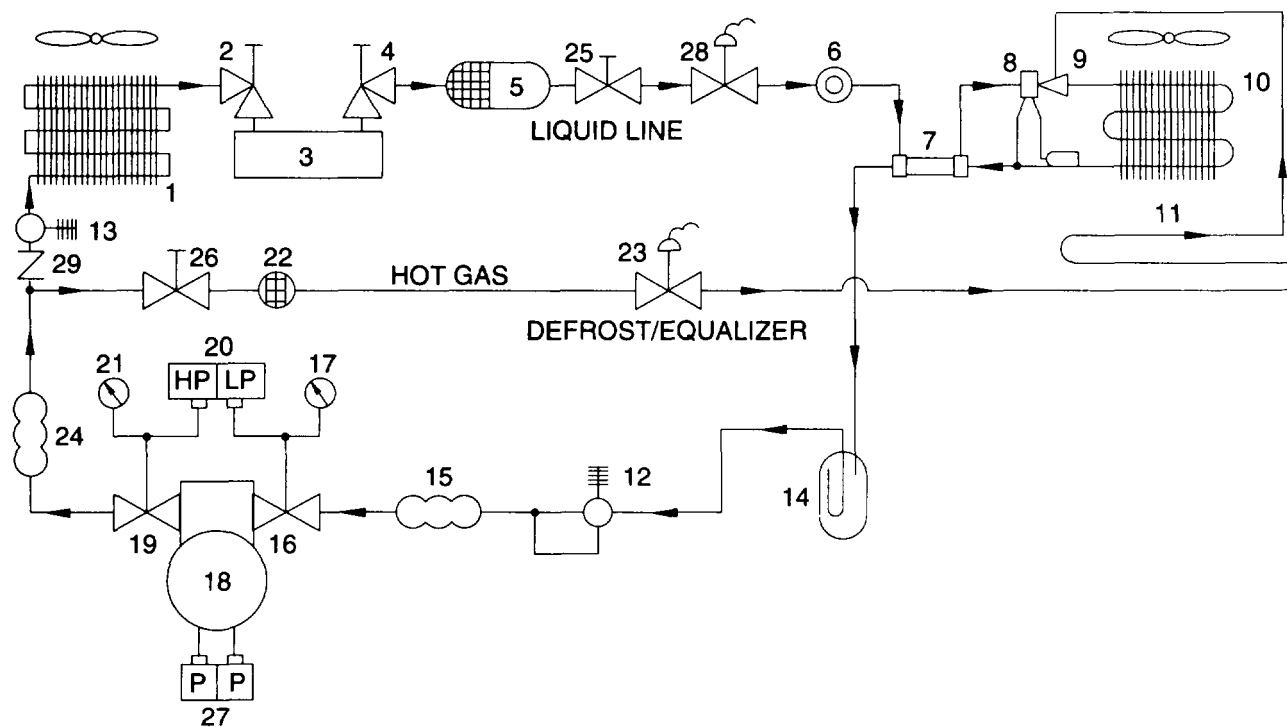

Figure 1-5. Refrigeration System



LEGEND			
ITEM	DESCRIPTION	ITEM	DESCRIPTION
1	CONDENSER	15	VIBRATION ABSORBER
2	SHUT-OFF VALVE	16	SUCTION SERVICE VALVE
3	RECEIVER	17	COMPOUND GAUGE
4	SHUT-OFF VALVE	18	COMPRESSOR
5	FILTER DRIER	19	DISCHARGE SERVICE VALVE
6	MOISTURE LIQUID INDICATOR	20	DUAL PRESSURE CUTOFF SWITCH
7	HEAT EXCHANGER	21	HEAD PRESSURE GAUGE
8	THERMOSTATIC EXPANSION VALVE	22	STRAINER
9	DISTRIBUTOR	23	SOLENOID VALVE, N.O. (DEFROST/EQL)
10	EVAPORATOR	24	VIBRATION ABSORBER
11	DEFROST COIL	25	SHUT-OFF VALVE
12	CRANKCASE PRESSURE REGULATOR	26	SHUT-OFF VALVE
13	DISCHARGE PRESSURE REGULATOR	27	DIFFERENTIAL OIL PRESSURE SWITCH
14	SUCTION ACCUMULATOR	28	SOLENOID VALVE, N.C. (LIQUID LINE)
		29	CHECK VALVE

Figure 1-6. Refrigeration Schematic

1-15. AIR HANDLING SYSTEM.

a. Refrigerator Enclosure. To absorb heat and cool the refrigerator enclosure, air must be circulated through the evaporator section of the refrigeration unit. Refrigerator enclosure air is drawn in through the coil guard and evaporator coil by the evaporator fan. The air is discharged through the evaporator air outlet guard back into the refrigerator enclosure.

b. Outside Ambient. To release heat absorbed in the refrigerator enclosure to the outside ambient, air must be circulated through the condenser section of the refrigeration unit. Outside ambient air is drawn in through the condenser guard and condenser coil by the condenser fan. The air is discharged through the side condenser doors and upper front door back to the outside ambient.

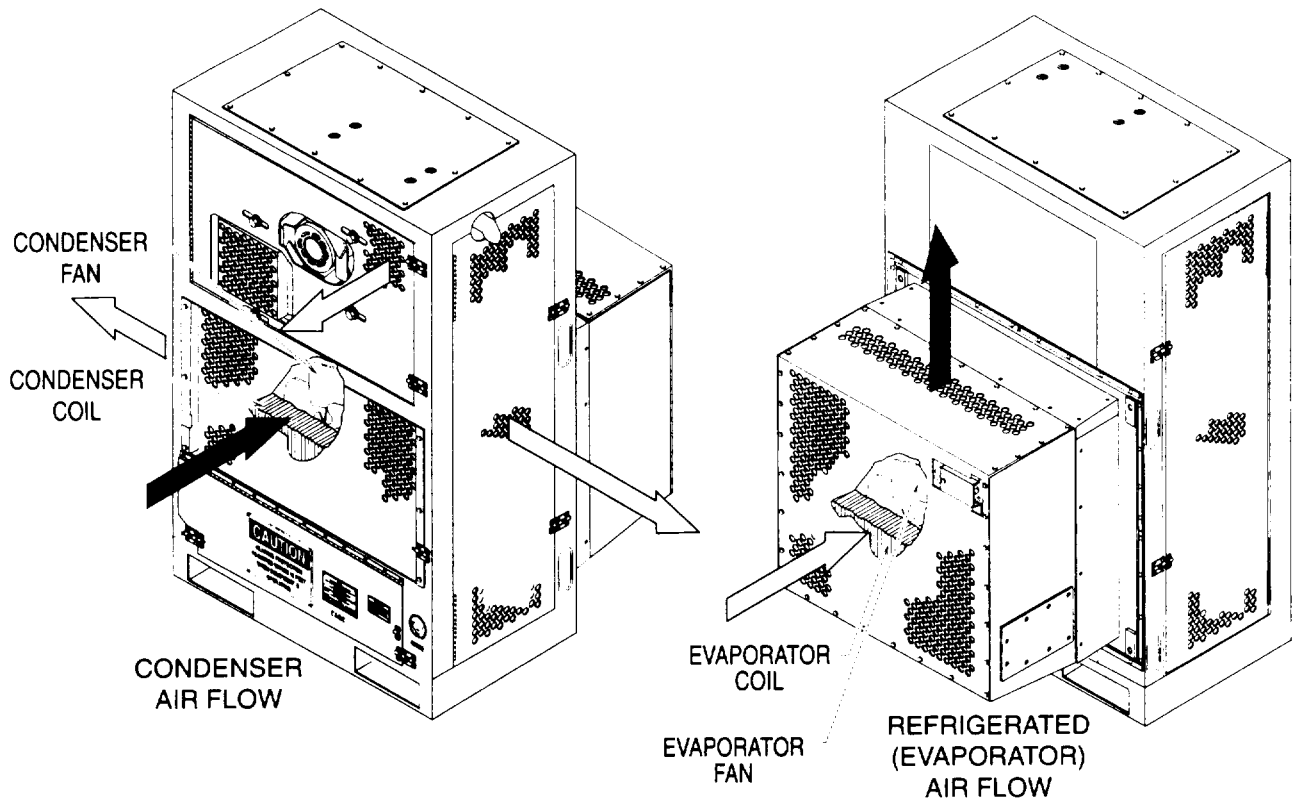

Figure 1-7. Air Handling System

CHAPTER 2

OPERATING INSTRUCTIONS

	Page
SECTION I	DESCRIPTION AND USE OF OPERATOR'S CONTROLS AND INDICATORS 2-1
2-1	Operating Controls and Indicators..... 2-1
2-2	Fault Controls and Indicators 2-4
SECTION II	PREVENTIVE MAINTENANCE CHECKS AND SERVICES (PMCS) 2-6
2-3	General 2-6
SECTION III	OPERATION UNDER USUAL CONDITIONS 2-22
2-4	Assembly and Preparation for Use..... 2-22
2-5	Startup Procedures 2-22
2-6	Operator Checks 2-26
2-7	Shutdown Procedures..... 2-27
2-8	Decals and Instruction Plates..... 2-27
SECTION IV	OPERATION UNDER UNUSUAL CONDITIONS 2-30
2-9	Operation Under Inclement Weather 2-30
2-10	NBC Decontamination Procedures 2-31

SECTION I. DESCRIPTION AND USE OF OPERATOR'S CONTROLS AND INDICATORS

2-1. OPERATING CONTROLS AND INDICATORS.

The controls and indicators needed to operate and monitor the refrigeration unit are located on the control box assembly, housing frame, and inside the housing.

- 1 Circuit Breaker (ENGINE FAULT RESET). Provides electrical circuit protection for the refrigeration unit control systems. The circuit breaker button can be pushed to place it in either the on (button in with no white band showing) or off (button extended with white band exposed) position. The circuit breaker should normally be kept in the on position.
- 2 Remote Bulb Thermostat (TEMPERATURE CONTROL). Monitors and automatically controls the temperature inside the refrigerator enclosure. The remote bulb thermostat should be set to the desired refrigerator enclosure temperature.
- 3 Toggle Switch (START/RUN, OFF, GLOW PLUG). Activates the refrigeration unit in the START/RUN position and activates the glow plug for cold weather starting in the GLOW PLUG position. The toggle switch should be in the START/RUN position to operate the refrigeration unit and the OFF position when not in use.

2-1. OPERATING CONTROLS AND INDICATORS. - Continued

- 4 Thermometer (REFRIGERATION TEMPERATURE). Indicates the refrigerator enclosure temperature. The thermometer should indicate within 15° F (8° C) of the temperature set on the remote bulb thermostat.
- 5 Pressure Gage (DISCHARGE PRESSURE). Indicates the pressure of the refrigerant gas leaving the compressor. The pressure gage should generally indicate between 165 and 250 psi (1139 and 1725 kPa), at start up and/or operation in high temperatures, this range can go higher. The inner scale indicates the temperature of the refrigerant at any given pressure.
- 6 Compound Gage (SUCTION PRESSURE). Indicates the pressure of the refrigerant gas entering the compressor. The compound gage should generally indicate between 0 and 15 psi (0 and 104 kPa), at shut down and/or operation in low temperatures, this range can go lower. The inner scale indicates the temperature of the refrigerant at any given pressure.
- 7 Sight Indicator (REFRIGERANT SIGHT GLASS). Provides a port through which the refrigerant may be observed as it passes through the liquid line of the refrigeration system. The center indicator changes color as it reacts to moisture in the refrigerant. The sight indicator port should be clear, indicating liquid refrigerant passing through it. An occasional flash of bubbles is normal as the refrigerant system automatically adjusts to changing conditions. The center indicator should be green or chartreuse in color.
- 8 Sight Glass (COMPRESSOR OIL SIGHT GLASS). Provides a port through which the oil level in the compressor may be observed. The sight glass port should show an oil level between 1/4 and 1/2 up the port. Bubbles in or on the oil surface is normal.
- 9 Hourmeter (HOURMETER). Indicates the total number of hours the engine/compressor has operated.
- 10 Lamp (DEFROST IN PROGRESS). Indicates, by illuminating, when the refrigeration unit is operating in a defrost cycle.
- 11 Fuel Gage (FUEL GAGE). Indicates the relative level of fuel in the fuel tank. The gage should always be above 1/4 mark during normal operation.
- 12 Ammeter (AMMETER). Indicates approximate amperage and relative flow of current to or from the battery. Flow from the battery (discharging) is indicated by negative (-) numbers and flow to the battery (charging) is indicated by positive (+) numbers. The ammeter should indicate a positive flow during normal operation, the amperage will vary depending on conditions.

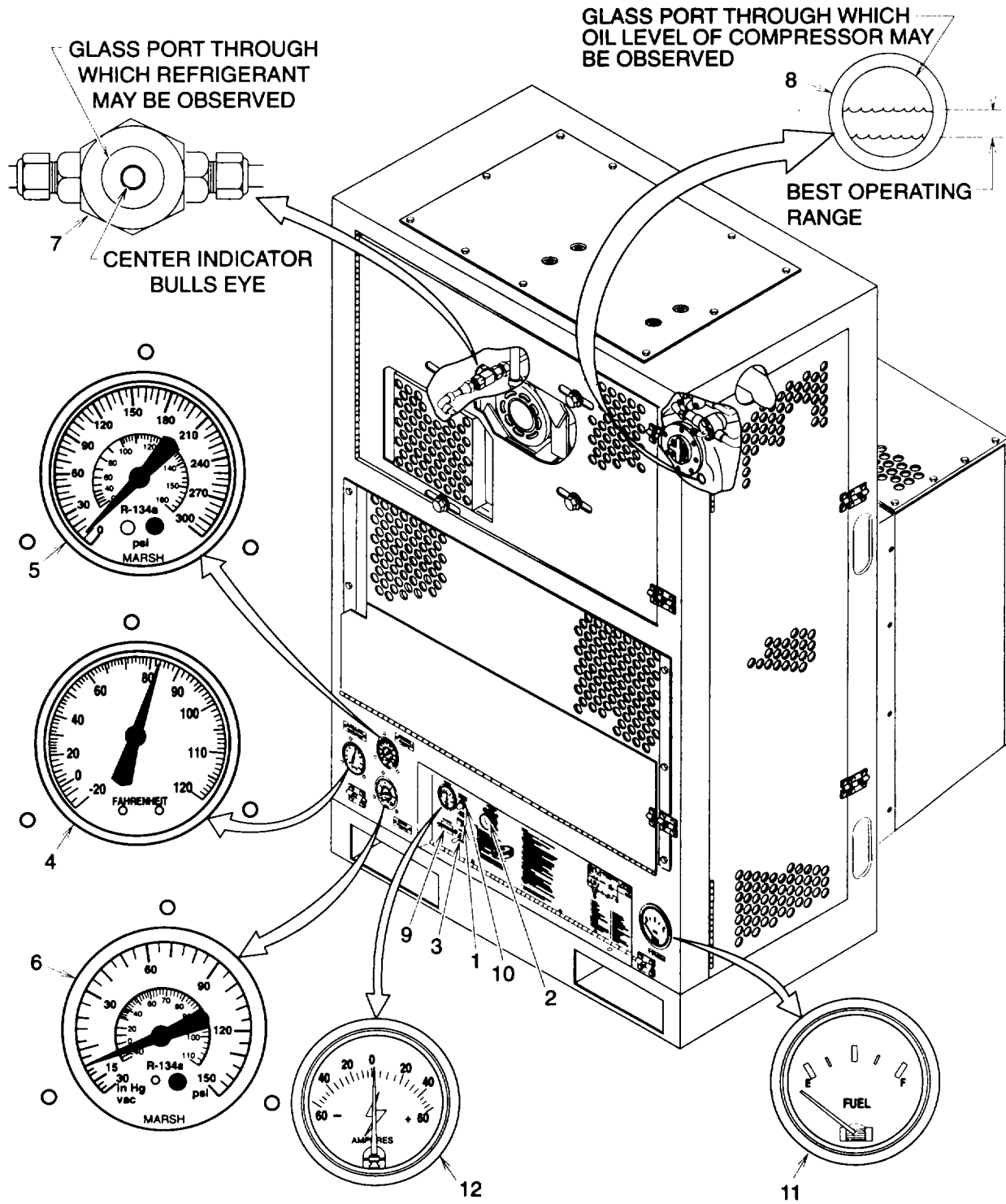

Figure 2-1. Operating Controls and Indicators

2-2. FAULT CONTROLS AND INDICATORS.

The controls and indicators needed to monitor and reset a fault condition on the refrigeration unit are located on the control box assembly and inside the condenser frame.

- 1 Thermometer (REFRIGERATION TEMPERATURE). The thermometer will indicate more than 150 F (8° C) above or below the remote bulb thermostat setting if a fault occurs in the temperature control system.
- 2 Pressure Gage (DISCHARGE PRESSURE). The pressure gage will indicate more than 250 psi (1725 kPa) or less than 165 psi (1139 kPa) if a fault occurs in the refrigeration system. At start up, shut down, or operation in high temperatures, this range can go higher.
- 3 Compound Gage (SUCTION PRESSURE). The compound gage will indicate more than 15 psi (104 kPa) or less than 0 psi (0 kPa) if a fault occurs in the refrigeration system. At start up, shut down, or operation in low temperatures, this range can go lower.
- 4 Circuit Breaker (ENGINE FAULT RESET). The circuit breaker button will be extended with a white band exposed if a fault has caused excessive load on the electrical control system. To reset the circuit breaker, push it in so the white band is no longer exposed.
- 5 Ammeter (AMMETER). The ammeter will show a negative (-) number indicating the battery is being discharged. This normally indicates a failure in the charging system.
- 6 Dual Pressure Control Switch. The dual pressure control switch will open the electrical control circuit if a fault in the refrigeration system causes the pressure of the refrigerant gas leaving the compressor to exceed 300 psi (2070 kPa). Push the reset button to reset the dual pressure control switch.
- 7 Differential Oil Pressure Switch. The differential oil pressure switch will open the electrical control circuit if a fault in the refrigeration system causes the compressor oil pressure to drop. Push the reset button to reset the differential oil pressure switch.
- 8 Sight Indicator (REFRIGERANT SIGHT GLASS). The sight indicator port will show continuous bubbles or foam in the refrigerant if there is a fault in the refrigeration system. The center indicator color will be yellow if moisture in the refrigerant exceeds safe operating limits.
- 9 Sight Glass (COMPRESSOR OIL SIGHT GLASS). The sight glass port will show the compressor oil level less than 1/4 up the port or will show the oil foaming if there is a fault in the refrigeration system.
- 10 Fuel Gage (FUEL GAGE). Indicates below 1/4 level. The fuel tank needs to be filled to maintain a fuel level above 1/4 for reliable operation.

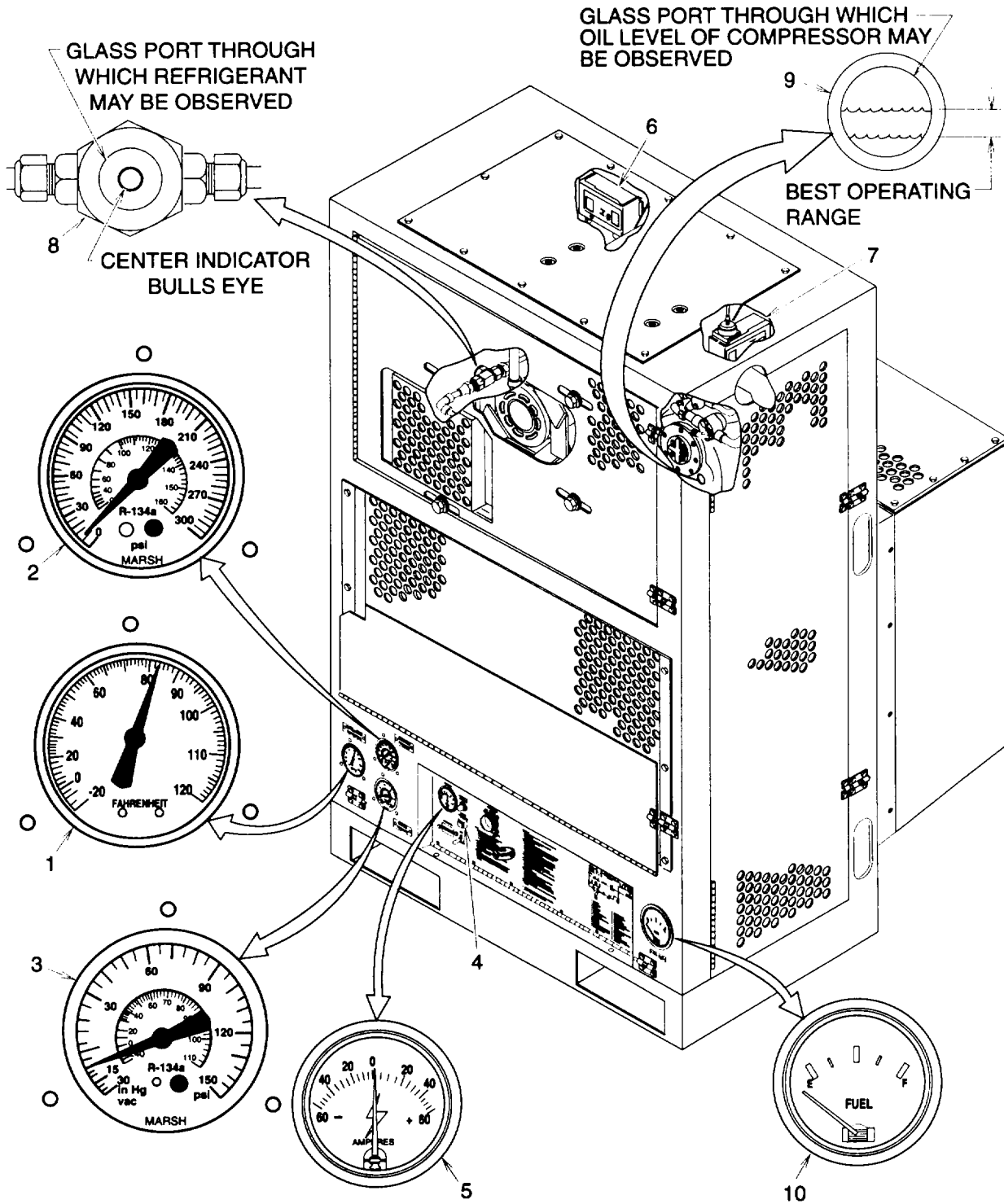

Figure 2-2. Fault Controls and Indicators

SECTION II. OPERATOR PREVENTIVE MAINTENANCE CHECKS AND SERVICES (PMCS)

2-3. GENERAL.

Preventive Maintenance Checks and Services (PMCS) are essential to the efficient operation of the refrigeration unit and to prevent possible damage that might occur through neglect or failure to observe warning symptoms in a timely manner. Checks and services performed by operators are limited to those functions which can be done from the outside of the cabinet or behind access doors. The Preventive Maintenance Checks and Services Table 2-1 lists the inspections and care of the refrigeration unit required to keep it in good operating condition.

a. Warnings and Cautions. Always observe the WARNINGS and CAUTIONS appearing in your PMCS Table. Warnings and cautions appear before applicable procedures. You must observe these WARNINGS and CAUTIONS to prevent serious injury to yourself and others or prevent your equipment from being damaged.

b. Explanation of Table Entries.

(1) Item Number Column. Numbers in this column are for reference. When completing DA Form 2404 (Equipment Inspection and Maintenance Worksheet), include the item number for the check/service indicating a fault. Item numbers also appear in the order that you must do checks and services for the intervals listed.

(2) Interval Column. This column tells you when you must do the procedure in the procedure column. BEFORE procedures must be done before you operate or use the equipment for its intended mission. DURING procedures must be done during the time you are operating or using the equipment for its intended mission. AFTER procedures must be done immediately after you have operated or used the equipment. When a check and service procedure is required for both WEEKLY and BEFORE intervals, it is not necessary to do the procedure twice if the equipment is operating during the WEEKLY period.

(3) Location, Check/Service Column. This column provides the location and the item to be checked or serviced. The item location is underlined.

(4) Procedure Column. This column gives the procedure you must do to check or service the item listed in the Check/Service column to know if the equipment is ready or available for its intended mission or for operation. You must do the procedure at the time stated in the interval column.

(5) Not Fully Mission Capable IF: Column. Information in this column tells you what faults will keep your equipment from being capable of performing its primary mission. If you made a check and service procedure that shows faults listed in this column, do not operate the equipment. Follow standard operating procedures for maintaining the equipment or reporting equipment failure.

c. Other Table Entries. Be sure to observe all special information and notes that appear in your table.

d. Leakage Definitions for Operator PMCS. It is necessary for you to know how fluid leakage affects the status of your refrigeration unit. The following are types/classes of leakages an operator needs to know to be able to determine the status of their unit. When in doubt notify your supervisor.

(1) Refrigerant Leaks. Oil is carried with the refrigerant as it flows through the refrigeration system. If a leak develops in the system, the oil will seep out and soak the copper tubing around the leak or drip and soak or puddle on the housing or other component below the leak. If any oil or seepage is found, a refrigerant leak would be suspected.

WARNING

The accumulation of liquid fuel is a fire hazard.

(2) Engine Fuel Leaks. Fuel is carried from the fuel tank, through filters, into the engine, and back to the fuel tank through various rubber hoses and fittings. If a leak develops, the fuel will seep out and soak the hose or fitting around the leak and may drip and soak or puddle on the housing or other component below the leak. If any fuel seepage is found, a leak would be suspected.

(a) Wipe and wash down such areas or surfaces promptly.

(b) Dispose of any wiping rags in approved containers. Contact your local environmental officer for guidance on how to properly dispose of fuel soaked wiping rags in accordance with local regulations.

(c) Apply no smoking rules within 50 ft of any fuel accumulation.

(3) Engine Lubricating Oil Leaks. Engine lubricating oil is carried from the engine, through filters, and back to the engine through various rubber hoses and fittings. If a leak develops, the oil will seep out and soak the hose or fitting around the leak and may drip and soak or puddle on the housing or other component below the leak. If any oil seepage is found, a leak would be suspected.

CAUTION

- **The refrigeration unit will not be operated with an obvious fuel leak.**
- **Operation is allowable with minor leakages (class I or II) in the engine lubricating oil system. Consideration must be given to oil capacity in the engine.**
- **When operating with class I or II oil leaks, continue to check oil level as required in your PMCS.**
- **Class III oil leaks should be reported immediately to your supervisor and the unit must be shut down.**

(a) Class I leak is defined as seepage of fluid as indicated by wetness or discoloration but not great enough to form drops.

(b) Class II leak is defined as leakage of fluid great enough to form drops but not enough to cause drops to drip from item being checked/inspected.

(c) Class III leak is defined as leakage of fluid great enough to form drops that fall from item being checked / inspected.

2-3. GENERAL - Continued

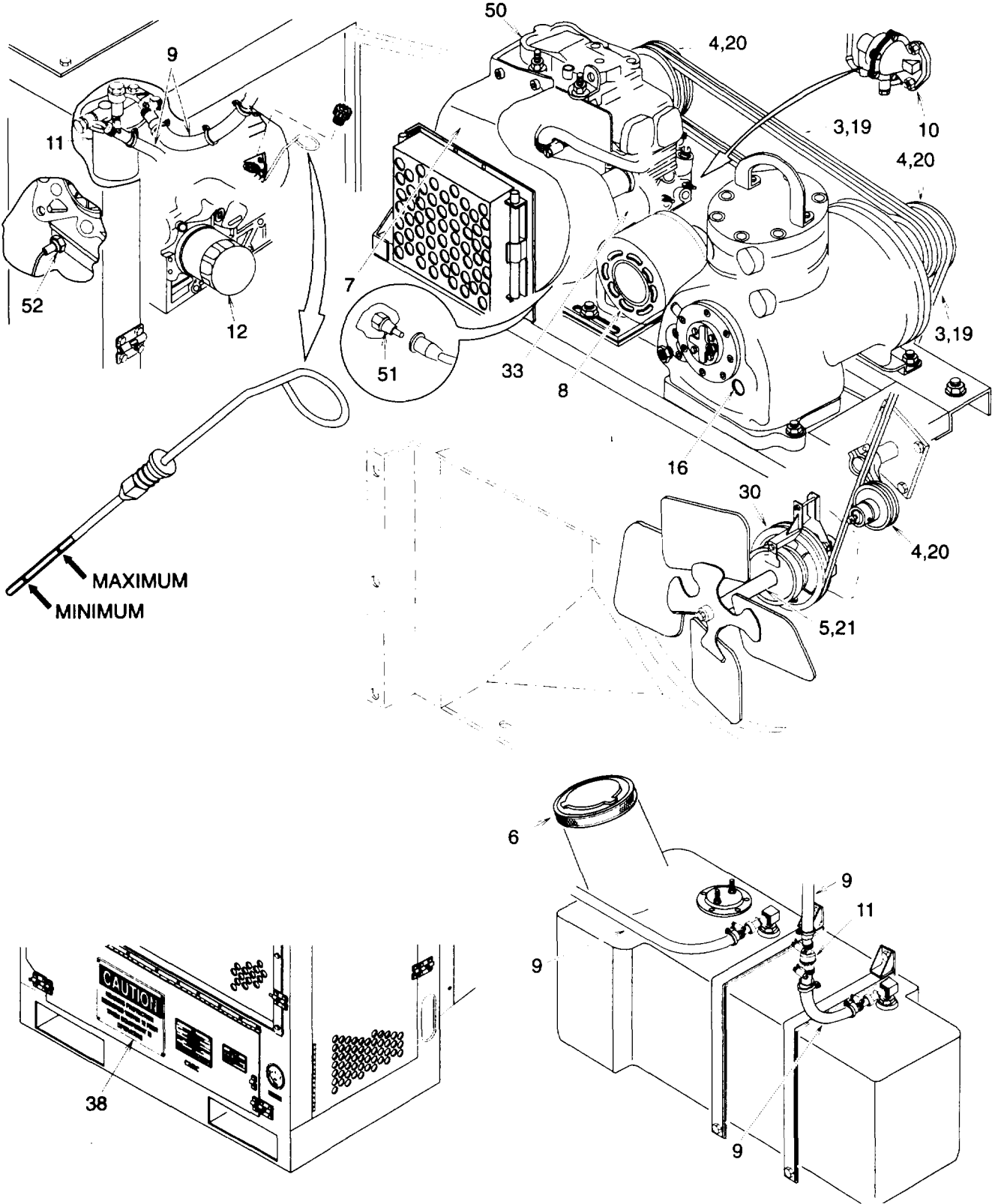

Figure 2-3. Operator PMCS Routing Diagram (Sheet 1 of 2)

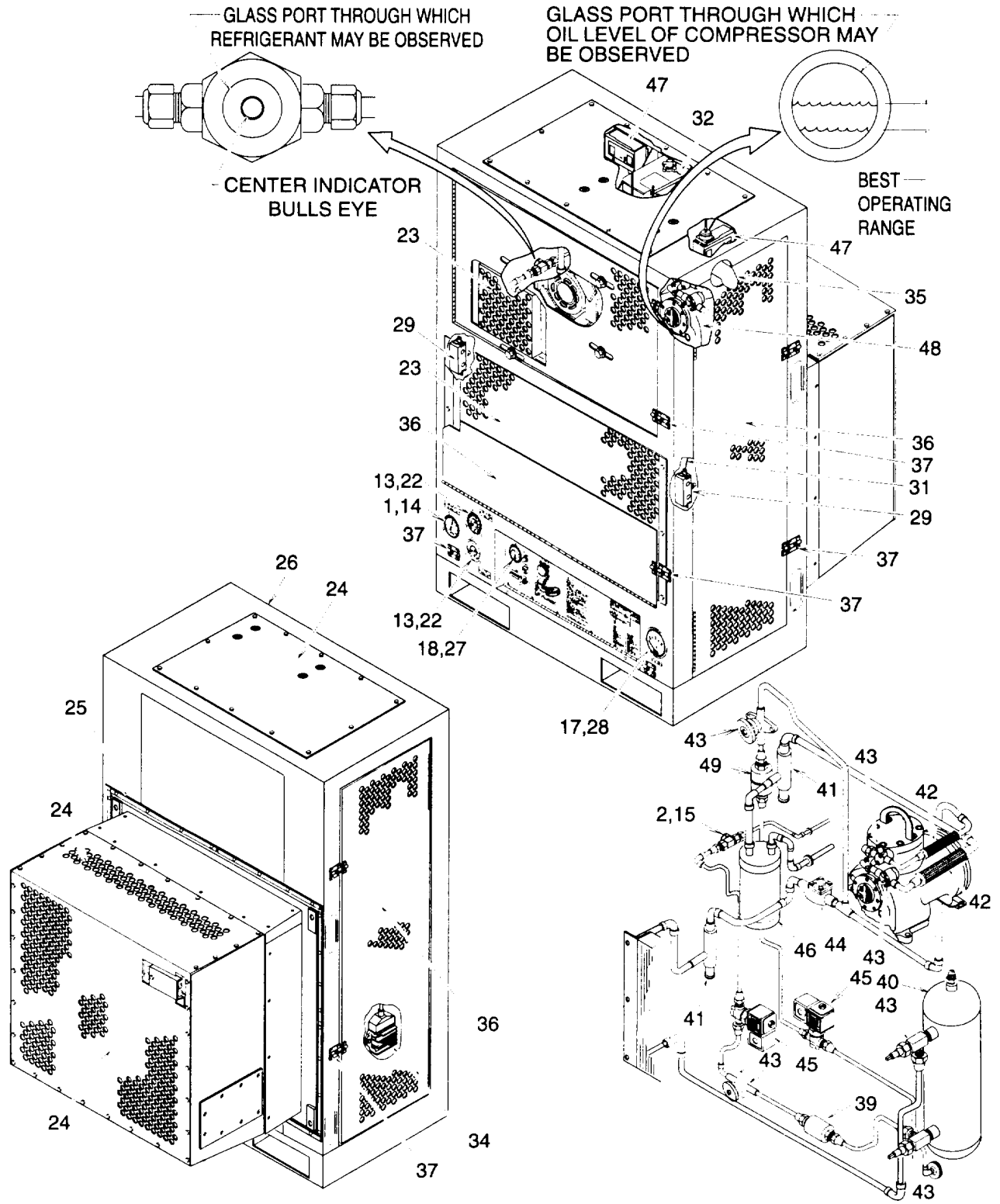

Figure 2-3. Operator PMCS Routing Diagram (Sheet 2 of 2)

Table 2-1. Operator Preventive Maintenance Checks and Services for Model F5000RD

NOTE

If the equipment must be kept in continuous operation, do only the procedures that can be done without disturbing operation. Make complete checks and services when the equipment is shut down.

Item No.	Interval	Location	Procedure	Not Fully Mission Capable If:
		Item to Check/Service		
1	Before	Refrigeration Unit Exterior	a. Temperature gage should indicate refrigerator enclosure temperature. If it does not, notify unit maintenance to replace it. b. Inspect the Temperature gage for cracked or missing lens and loose or missing mounting hardware. If damaged or loose, notify unit maintenance to tighten or replace it as necessary.	Temperature gage does not indicate refrigerator enclosure temperature.
		Temperature Gage		
2	Before	Refrigeration Unit Interior	<p style="text-align: center;">WARNING</p> Exposed rotating parts are contained in the refrigeration unit. Care must be taken when doors are open to prevent personal injury.	Evidence of leak is found.
		Sight Indicator		
3	Before	V-Belts	Inspect the V-belts for frayed edges, cracks, glazing, or hard brittle condition. Inspect for excessive looseness or slippage. If damaged or loose, notify unit maintenance to tighten or replace it as necessary.	V-belt is missing, frayed, cracked, glazed, or hard and brittle. V-belt is excessively loose or slipping.

Table 2-1. Operator Preventive Maintenance Checks and Services for Model F500RD - Continued

Item No.	Interval	Location	Procedure	Not Fully Mission Capable If:
		Item to Check/Service		
4	Before	Pulleys	Inspect pulleys for cracks, chips, or warpage. Inspect for secure mounting to shaft. or loose, notify unit maintenance to tighten or replace it as necessary.	Pulley is cracked, If damaged chipped, warped, or loose on shaft.
5	Before	Fan Drive Shaft	Inspect fan drive shaft for cracks, chips, or warpage. If damaged, notify direct support maintenance to replace it as necessary.	Fan drive shaft is cracked, chipped, or warped.
6	Before	Fuel Tank	<p style="text-align: center;">WARNING</p> <p>The fuel used in this refrigeration unit is highly explosive. Do not make or use open flame when performing maintenance. Flames and explosion could result in severe personal injury or death.</p> <p>Inspect fuel tank.</p> <p>a. Check for cuts, dents, cracks, or leaks. or leak is found.</p> <p>b. Service fuel tank by checking fuel level. level is less than 1/4 tank, top off with fuel (13, appendix E) if operating between 5° F (-15° C) and 125° F (52° C) or (14, appendix E) if operating between 0° F (-18° C) and 5° F (-15° C).</p>	<p>Fuel tank is cut, cracked,</p> <p>If Fuel level is less than 1/4 tank.</p>
7	Before	Engine	<p>Inspect engine.</p> <p>a. Check for fluid leaks.</p> <p>b. Service engine by checking oil level. Oil level is at the lower MINIMUM mark or below on the dipstick. Add oil to second MAXIMUM mark. If temperature is above 1040 F (40° C) use (item 12, appendix E), if temperature is between 5° F (-15° C) and 104° F (40° C) use (item 10, appendix E), if temperature is below 5° F (-15° C) use (item 11, appendix E).</p>	<p>Any fuel leak or class III oil fluid leak is found.</p> <p>Oil level is below the lower MINIMUM mark on the dipstick.</p>
8	Before	Air Cleaner	Inspect for missing or damaged air cleaner and attaching hardware.	Damaged or missing air cleaner and attaching hardware.

Table 2-1. Operator Preventive Maintenance Checks and Services for Model F500RD - Continued

Item No.	Interval	Location	Procedure	Not Fully Mission Capable If:
		Item to Check/Service		
9	Before	Fuel Lines	Inspect fuel lines (hoses) for cuts, cracks, and any leaking.	If fuel lines (hoses) are cut, cracked, leak is found.
10	Before	Fuel Pump	Inspect fuel pump for any cracks or leaks.	Fuel pump cracked or leak found.
11	Before	Fuel Filters	Inspect fuel filters for any dents, cuts, or leaks.	Fuel filter is dented, cut, or leak is found.
12	Before	Oil Filter	Inspect oil filter for any dents, cuts, or leaks.	Oil filter is dented, cut, or leak is found.
		<u>Refrigeration Unit Exterior</u>	<p style="text-align: center;">NOTE</p> <ul style="list-style-type: none"> • The gages must not be inspected when the DEFROST IN PROGRESS lamp is on. • Pressures given are the acceptable operating range. 	
13	During	Pressure and Compound Gages	Inspect the pressure gage for reading between 160 and 270 psi (1104 and 1863 kPa) and the compound gage for reading between 0 and 15 psi (0 and 104 kPa). If either gage is out of acceptable operating range on a continuous basis, note the readings and shut down the refrigeration unit (para 2-7). Notify unit maintenance of the pressure readings.	Gage reading above or below acceptable operating range.
			<p style="text-align: center;">NOTE</p> <p style="text-align: center;">The temperature gage must not be inspected when the DEFROST IN PROGRESS lamp is on.</p>	
14	During	Temperature Gage	Temperature gage should indicate within 15° F (8° C) of remote bulb thermostat setting. If out of this range, shut down refrigeration unit (para 2-7) and notify unit maintenance.	Temperature gage indicates more than 15° F (8° C) above or below remote bulb thermostat setting.

Table 2-1. Operator Preventive Maintenance Checks and Services for Model F5000RD - Continued

Item No.	Interval	Location	Procedure	Not Fully Mission Capable If:
		Item to Check/Service		
15	During	Sight Indicator	<p style="text-align: center;">NOTE</p> <ul style="list-style-type: none"> • The sight indicator must not be inspected when the DEFROST IN PROGRESS lamp is on. • The sight indicator can be viewed looking through the left side condenser door. <p>Inspect sight indicator port for constant bubbles or foaming and note center indicator color. If constant bubbles or yellow indicator are seen, shut down refrigeration unit (para 2-7) and notify direct support maintenance to leak check and evacuate refrigeration system as necessary.</p>	Sight indicator port shows constant bubbles or foam. Center indicator color is yellow.
16	During	Compressor (Oil Level Sight Glass)	<p style="text-align: center;">NOTE</p> <ul style="list-style-type: none"> • The sight glass must not be inspected when the DEFROST IN PROGRESS lamp is on. • The front door must be open to view the sight glass. • Safe operating level is between 1/4 and 1/2 way up the sight glass. <p>Inspect the sight glass port for low or high oil level and foaming. If oil level is out of safe operating range or foaming, shut down refrigeration unit and notify direct support maintenance to leak check and add oil to or remove oil from compressor as necessary.</p>	Sight glass port oil level above or below safe operating range or foaming.

Table 2-1. Operator Preventive Maintenance Checks and Services for Model F5000RD - Continued

Item No.	Interval	Location	Procedure	Not Fully Mission Capable If:
		Item to Check/Service		
17	During	Fuel Gage	<p>WARNING</p> <p>The fuel used in this refrigeration unit is highly explosive. Do not make or use open flame when performing maintenance. Flames and explosion could result in severe personal injury or death.</p> <p>Check fuel gage, if less than 1/4 full, shut down unit (para 2-7). Fill fuel tank with fuel (13, appendix E) if operating between 5° F (-15° C) and 120° F (49° C) or (14, appendix E) if operating between 0° F (-18° C) and 5° F (-15° C). Start unit (para 2-5).</p>	Fuel level is less than 1/4 full.
18	During	Ammeter <u>Refrigeration Unit Interior</u>	<p>Inspect ammeter indicator reading for normal operating range of 0 to +15 amperes.</p> <p>WARNING</p> <p>Exposed rotating parts are contained in the refrigeration unit. Care must be taken when doors are open to prevent personal injury.</p>	Indicator reading outside normal operating range.
19	After	V-Belts	<p>Inspect the V-belts for frayed edges, cracks, glazing, or hard brittle condition. Inspect for excessive looseness or slippage. If damaged or loose, notify unit maintenance to tighten or replace it as necessary.</p>	V-belt is frayed, cracked, glazed, or hard and brittle. V-belt is excessively loose or slipping.
20	After	Pulleys	<p>Inspect pulleys for cracks, chips, or warpage. Inspect for secure mounting to shaft. If damaged or loose, notify unit maintenance to tighten or replace it as necessary.</p>	Pulley is cracked, chipped, warped, or loose on shaft.
21	After	Fan Drive Shaft	<p>Inspect fan drive shaft for cracks, chips, or warpage. If damaged, notify direct support maintenance to replace it as necessary.</p>	Fan drive shaft is cracked, chipped, or warped.

Table 2-1. Operator Preventive Maintenance Checks and Services for Model F500RD - Continued

Item No.	Interval	Location	Procedure	Not Fully Mission Capable If:
		Item to Check/Service		
22	Weekly	Refrigeration Unit Exterior Pressure and Compound Gages	<ul style="list-style-type: none"> a. Inspect the gages for cracked or missing lens and loose or missing mounting hardware. If damaged or loose, notify direct support maintenance to tighten or replace it as necessary. b. Inspect the gages for evidence of refrigerant leak. If damaged or evidence of leaking found, notify direct support maintenance to replace it. 	Evidence of leak is found.
23	Weekly	Guards	<ul style="list-style-type: none"> a. Inspect the guards for any debris or foreign material obstructing the openings. Remove any debris or foreign material from the openings. If debris cannot be removed, notify unit maintenance to remove it. b. Inspect the guards for any cracks, tears, and loose or missing hardware. If cracked, notify direct support maintenance for repair. If hardware is loose or missing, notify unit maintenance to tighten or replace as necessary. c. Inspect for chipped or missing paint and evidence of corrosion. If paint is damaged or shows evidence of corrosion, notify direct support maintenance to paint it. 	Debris or foreign material obstructs the openings.
24	Weekly	Panels	<ul style="list-style-type: none"> a. Inspect the access panels for any cracks, tears, and loose or missing hardware. If cracked, notify direct support maintenance for repair. If hardware is loose or missing, notify unit maintenance to tighten or replace it as necessary. b. Inspect for any chipped or missing paint and evidence of corrosion. If paint is damaged or access panel shows evidence of corrosion, notify direct support maintenance to paint it. 	
25	Weekly	Heat Shield Gaskets	Inspect for loose or missing heat shield gasket and for splits or tears. If damaged or loose, notify unit maintenance to tighten or replace it as necessary.	

Table 2-1. Operator Preventive Maintenance Checks and Services for Model F500RD - Continued

Item No.	Interval	Location	Procedure	Not Fully Mission Capable If:
		Item to Check/Service		
26	Weekly	Housing	<ul style="list-style-type: none"> a. Inspect the housing for cracks and loose or missing hardware. If cracked, notify direct support maintenance for repair. If hardware is loose or missing, notify unit maintenance to tighten or replace it as necessary. b. Inspect the housing for any chipped or missing paint and evidence of corrosion. If paint is damaged or enclosure shows evidence of corrosion, notify direct support maintenance to paint it. c. Inspect the evaporator assembly condensate drain plastic tubing for any debris or foreign material obstructing it. Remove any debris or foreign material from the condensate drain tubing. If tubing cannot be cleaned, notify unit maintenance to clean it. d. Inspect for secure mounting to the refrigerator enclosure. If loose, notify unit maintenance to secure it. e. Inspect for missing or damaged mounting bolt assembly. If missing or damaged, notify unit maintenance to repair or replace it. 	<p>Debris or foreign material obstructing the condensate drain opening.</p> <p>Housing is loose on refrigerator enclosure.</p> <p>Unit mounting bolt is damaged or missing.</p>
27	Weekly	Ammeter	Inspect ammeter for cracked or damaged cover lens and cracks in case.	Cover lens damaged to interfere with accurate reading or crack in case.
28	Weekly	Fuel Gage	Inspect fuel gage for cracked or damaged cover lens and cracks in case.	Cover lens damaged to interfere with accurate reading or crack in case.

Table 2-1. Operator Preventive Maintenance Checks and Services for Model F500RD - Continued

Item No.	Interval	Location	Procedure	Not Fully Mission Capable If:
		Item to Check/Service		
29	Weekly	Refrigeration Unit Interior	<p style="text-align: center;">WARNING</p> <p>Exposed rotating parts are contained in the refrigeration unit. Care must be taken when doors are open to prevent personal injury.</p> <p>a. Inspect the push switches for cracked case and loose or missing attaching hardware. If damaged or loose, notify unit maintenance to tighten or replace it as necessary.</p> <p>b. Inspect the push switches for smooth operation. If binding, notify unit maintenance to test and replace it as necessary.</p> <p>c. Inspect the push switches for frayed or broken wire leads. If damaged, notify unit maintenance to repair or replace it as necessary.</p>	The push switches stick. Wire lead frayed or broken.
		Push (Door) Switches		
30	Weekly	Fan Clutch	<p>a. Inspect the fan clutch for loose or missing attaching hardware. If loose, notify unit maintenance to tighten it.</p> <p>b. Inspect the fan clutch for frayed or broken wire leads. If damaged, notify unit maintenance to repair or replace it as necessary.</p>	<p>Fan clutch loose.</p> <p>Wire lead frayed or broken.</p>
31	Weekly	Wires, Cables, and Harnesses	Inspect for cut or frayed wires and damaged terminals or clamps.	missing or Wire lead cut or frayed, terminal missing or damaged, or clamp missing or loose.
32	Weekly	Battery	Inspect battery for cracks, damaged terminal, and leaks.	Battery cracked, terminal damaged, or any evidence of leaking.
33	Weekly	Starting Motor	a. Inspect starting motor for any evidence of overheating such as discoloration of casing or burn marks.	Starting motor shows evidence of overheating.

Table 2-1. Operator Preventive Maintenance Checks and Services for Model F500RD - Continued

Item No.	Interval	Location	Procedure	Not Fully Mission Capable If:
		Item to Check/Service		
33 Cont	Weekly	Voltage Regulator	b. Inspect the starting motor for frayed or broken wire leads. If damaged, notify unit maintenance to repair or replace it as necessary.	Wire leads are frayed or broken.
34			a. Inspect voltage regulator for any evidence of overheating such as discoloration of casing or burn marks. b. Inspect the voltage regulator for frayed or broken wire leads. If damaged, notify unit maintenance to repair or replace it as necessary.	Voltage regulator shows evidence of overheating. Wire leads are frayed or broken.
35	Weekly	Muffler, Exhaust Pipes, and Clamps	<p>WARNING Muffler may be hot to touch and can cause serious personal injury. Allow muffler to cool.</p> Inspect muffler and exhaust pipes for holes or dents and missing or damaged clamps.	Hole in muffler, exhaust pipes or clamps missing or loose.
36	Monthly	Refrigeration Unit Exterior Doors/Cover	a. Inspect the side condenser doors, front bottom doors, and control box cover for any cracks, tears, and loose or missing hardware. If cracked, notify direct support maintenance for repair. If hardware is loose or missing, notify unit maintenance to tighten or replace as necessary. b. Inspect the doors and cover for any chipped or missing paint and evidence of corrosion. If paint is damaged or shows evidence of corrosion, notify direct support maintenance to paint it. c. Inspect the hinges for smooth operation and loose or missing attaching hardware. If hinges bind, notify unit maintenance to lubricate them. If attaching hardware is loose or missing, notify direct support maintenance to replace it.	The side condenser doors do not stay closed.

Table 2-1. Operator Preventive Maintenance Checks and Services for Model F5000RD - Continued

Item No.	Interval	Location	Procedure	Not Fully Mission Capable If:
		Item to Check/Service		
37	Monthly	Barrel Bolts	Inspect the barrel bolts for smooth operation and loose or missing attaching hardware. If barrel bolts bind, notify unit maintenance to lubricate them. If attaching hardware is loose or missing, notify unit maintenance to tighten or replace it as necessary.	
38	Monthly	Plates	Inspect for any damaged, loose, or missing information plates and loose or missing attaching hardware. If information plates are damaged or loose, notify direct support maintenance to tighten or replace them as necessary.	
		<u>Refrigeration Unit Interior</u>	<p>WARNING</p> <p>Exposed rotating parts are contained in the refrigeration unit. Care must be taken when doors are open to prevent personal injury.</p>	
39	Monthly	Dehydrator	Inspect the dehydrator for damage or evidence of refrigerant leak. If damaged or evidence of leaking found, notify direct support maintenance to replace it.	Dehydrator is damaged or evidence of leak is found.
40	Monthly	Receiver	Inspect the receiver for damage and evidence of refrigerant leak. Inspect the isolation valves for evidence of refrigerant leak. If damaged or evidence of leaking found, notify direct support maintenance to replace it.	Receiver is damaged or evidence of leak is found.
41	Monthly	Pressure Regulator Valves	Inspect the pressure regulator valves for damage or evidence of refrigerant leak. If damaged or evidence of leaking found, notify direct support maintenance to replace it.	Pressure regulator valve damaged or evidence of leak is found.
42	Monthly	Metal Hose Assemblies	Inspect the metal hose assemblies for kinks or evidence of refrigerant leak. If damaged or evidence of leaking found, notify direct support maintenance to replace it.	Metal hose assembly kinked or evidence of leak is found.
43	Monthly	Valves	Inspect the valves for evidence of refrigerant leak. If evidence of leaking found, notify direct support maintenance to replace it.	Evidence of leak is found.

Table 2-1. Operator Preventive Maintenance Checks and Services for Model F500RD - Continued

Item No.	Interval	Location	Procedure	Not Fully Mission Capable If:
		Item to Check/Service		
44	Monthly	Check Valve	Inspect the check valve for evidence of refrigerant leak. If evidence of leaking found, notify direct support maintenance to replace it.	Evidence of leak is found.
45	Monthly	Solenoid Valves/Coils	Inspect the solenoid valves for frayed or broken wire leads, loose coil, loose or missing cover, and evidence of refrigerant leak. If coil is loose or damaged or wire leads are frayed or broken, notify unit maintenance to repair or replace it as necessary. If evidence of leaking found, notify direct support maintenance to replace it.	Wire lead frayed or broken, coil loose, or evidence of leak is found.
46	Monthly	Accumulator	Inspect the accumulator for damage and evidence of refrigerant leak. If damaged or evidence of leaking found, notify direct support maintenance to replace it.	Accumulator is damaged or evidence of leak is found.
47	Monthly	Pressure Switches	Inspect the pressure switches for frayed or broken wire leads and dented, loose, or missing cover. Inspect for evidence of refrigerant leak. If cover is loose or wire leads are frayed or broken, notify unit maintenance to repair or replace it as necessary. If damaged or evidence of leaking found, notify direct support maintenance to replace it.	Wire lead frayed or broken, cover missing, or evidence of leak is found.
48	Monthly	Compressor	Inspect the compressor sight glass for cracks. Inspect for evidence of refrigerant leak. If damaged or evidence of leaking found, notify direct support maintenance to repair or replace as necessary.	Sight glass cracked or evidence of leak is found.
49	Monthly	Strainer	Inspect the strainer for damage or evidence of refrigerant leak. If damaged or evidence of leaking found, notify direct support maintenance to replace it.	Strainer is damaged or evidence of leak is found.
50	Monthly	Cylinder Head	<p>a. Inspect cylinder head for any evidence of overheating such as discoloration or burn marks. If overheated, notify direct support maintenance.</p> <p>b. Inspect cylinder head for damage such as dents or cracks. If damaged, notify direct support maintenance to replace it.</p>	<p>Cylinder head shows evidence of overheating.</p> <p>Cylinder head is damaged.</p>

Table 2-1. Operator Preventive Maintenance Checks and Services for Model F500RD - Continued

Item No.	Interval	Location	Procedure	Not Fully Mission Capable If:
		Item to Check/Service		
51	Monthly	Engine Oil Pressure Switch	Inspect the switch for frayed or broken wire lead and evidence of leak. If wire lead is frayed or broken, notify unit maintenance to repair or replace it as necessary. If evidence of leaking found, notify unit maintenance to replace it.	Wire lead frayed or broken or class III leak is found.
52	Monthly	Engine Temperature Switch		

SECTION III OPERATION UNDER USUAL CONDITIONS

2-4. ASSEMBLY AND PREPARATION FOR USE.

The refrigeration unit requires specialized unpacking, installation, and initial adjustment procedures. Notify unit maintenance for installation.

WARNING

Operating the refrigeration unit in a building or any enclosed area without the exhaust gases piped outside can result in serious illness or death.

NOTE

The refrigeration unit is designed to operate under adverse environmental conditions such as rain, snow, etc. in temperatures from 0° F to 125° F (-17° C to 52° C). The following startup procedures apply to operation in temperatures from 40° F to 104° F (4° C to 45° C). For temperatures outside this range, see operating instructions for unusual conditions.

2-5. STARTUP PROCEDURES.

See figure 2-4.

CAUTION

Operating the refrigeration unit with the service valves improperly set will damage the equipment. Do not operate unless you are sure it has been properly set up for operation. Notify unit maintenance.

- a. Be sure the refrigeration unit has been properly prepared and adjusted for operation.
- b. Perform all your "BEFORE" PMCS functions (table 2-1).

NOTE

Push switches in the side condenser door frames will prevent the refrigeration unit from operating if the side doors are open.

- c. Be sure side condenser doors (1) and (2) are closed and secured.
- d. Raise and latch control box cover door (3).
- e. Set the remote bulb thermostat (TEMPERATURE CONTROL) (4) to the desired refrigerator enclosure temperature.
- f. Be sure circuit breaker button (ENGINE FAULT RESET) (5) is pushed in (white band is not visible).
- g. Be sure the FUEL GAGE (6) is indicating fuel level above 1/4.

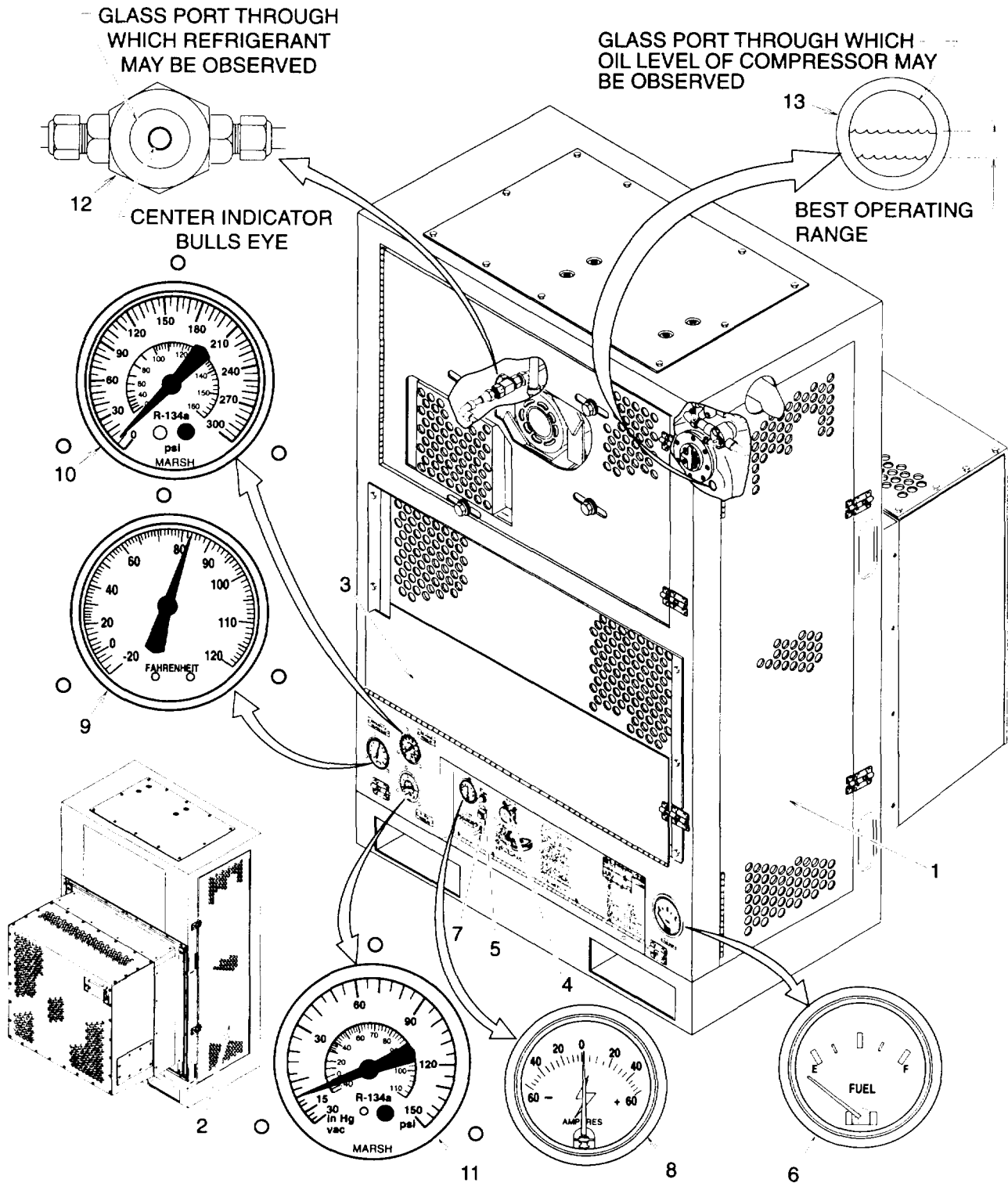

Figure 2-4. Operator Controls and Indicators (Sheet 1 of 2)

2-5. STARTUP PROCEDURES. - Continued

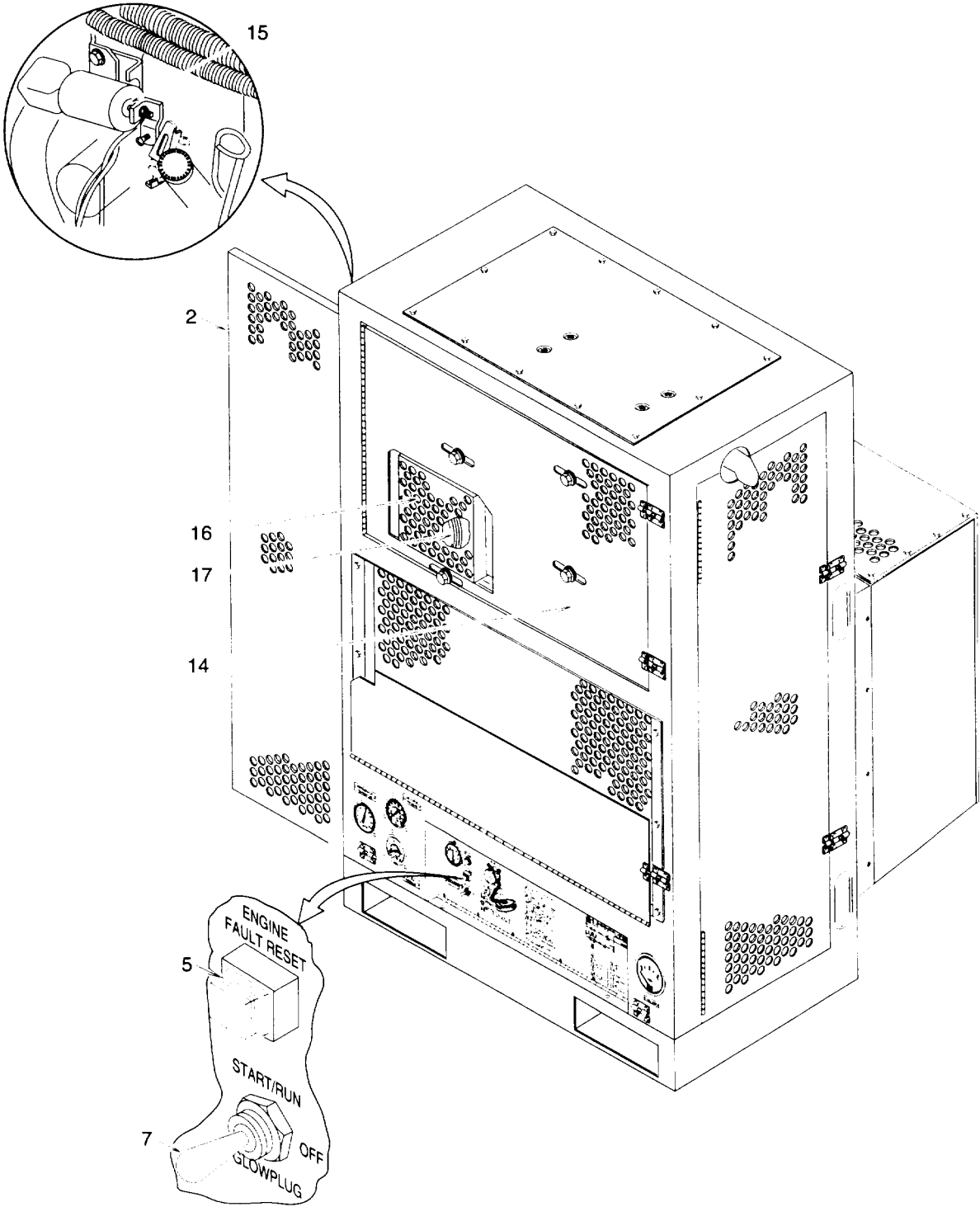

Figure 2-4. Operator Controls and Indicators (Sheet 2 of 2)

WARNING

- **The refrigeration unit engine produces dangerously high noise levels reaching 96 dB (A) at the service position. Approved hearing protection must be worn any time personnel are within 12 feet of an operating unit to avoid temporary or possibly permanent hearing damage.**
 - **Engines have fast moving parts that can injure hands, fingers, etc. Take special care while in operation. Engine parts, particularly the exhaust system, can be very hot and cause severe burns. Do not touch until engine is shut down and cooled off. Avoid spilling fuel or oil on hot engine parts which could result in a fire.**
- h. Place the toggle switch (START/RUN, OFF, GLOW PLUG) (7) handle in the START/RUN position. After unit starts, lower and latch control box cover door (3) to prevent restriction of condenser air flow.
- i. If the refrigeration unit does not start automatically, manual start the unit per the following.

NOTE

The engine cannot be manually started at temperatures below (40° F (4° C)).

(1) Open left side door (2) and front door (14). Loop a piece of wire, string, or other suitable material around the fuel shut-off valve (15) shaft that is long enough to reach through the front door.

NOTE

Push switches in the side condenser door frames will prevent the refrigeration unit from operating if the side doors are open.

(2) The wire/string loop will be used to manually activate the fuel shut-off valve (15) to the operating position and must be held until the engine is started. Close the left side door (2).

(3) Push the ENGINE FAULT RESET button (5) to the off position (white band visible).

(4) Open the engine guard door (16) and turn the flywheel (17) CCW until you feel resistance indicating you have reached a compression stroke. If you over turn and feel no resistance, continue to turn until you feel the beginning of the next compression stroke.

(5) Wrap a pull rope CW onto the flywheel (17).

(6) Pull on the wire/string to activate the fuel shut-off valve (15) to the operating position and hold.

(7) Place the toggle switch START/RUN, OFF, GLOW PLUG (7) handle in the START/RUN position and pull the rope.

(8) If the engine does not start, place the toggle switch START/RUN, OFF, GLOW PLUG (7) handle in the OFF position and repeat steps (4) thru (7).

(9) If the engine starts, close engine guard door (16). Remove wire/string and close front door (14). Push the ENGINE FAULT RESET button (5) to the on position (white band not visible). After unit starts, lower and latch control box cover (3) to prevent restriction of condenser air flow.

2-6. OPERATOR CHECKS.

See figure 2-4.

- a. Perform all your "DURING" PMCS functions (table 2-1).
- b. Check the AMMETER (8) periodically to be sure it is indicating a positive (+) number.

NOTE

All checks must be performed when the DEFROST IN PROGRESS lamp is off.

- c. Check the thermometer (REFRIGERATION TEMPERATURE) (9) periodically to be sure it is within 15° F (8° C) of the temperature set on the remote bulb thermostat (TEMPERATURE CONTROL) (4).
- d. Check the pressure gage (DISCHARGE PRESSURE) (10) periodically to be sure it is between 165 and 250 psi (1139 and 1725 kPa).
- e. Check the compound gage (SUCTION PRESSURE) (11) periodically to be sure it is between 0 and 15 psi (0 and 104 kPa).

NOTE

An occasional flash of bubbles in the sight indicator (SIGHT GLASS) port is normal. The sight indicator can be viewed looking through the side condenser door.

- f. Check the sight indicator (SIGHT GLASS) (12) port to be sure it is clear. The center indicator should be green or chartreuse in color.

NOTE

Occasional bubbles in the compressor sight glass oil is normal. The sight glass can be viewed looking through the front bottom panel.

- g. Check the compressor sight glass (13) port to be sure the oil is clear and the level is between 1/4 and 1/2 up the port.
- h. Check the FUEL GAGE (6) periodically to be sure it is indicating a fuel level above 1/4.

2-7. SHUTDOWN PROCEDURES.

See figure 2-4.

NOTE

If the refrigeration unit is to be left off for several days, it must be pumped down. Notify Unit Maintenance.

- a. Place the toggle switch (START/RUN, OFF, GLOW PLUG) (7) handle in the OFF position.
- b. When the refrigeration unit stops running, push the circuit breaker button (ENGINE FAULT RESET) (5) to put it in the off position (button extended with white band exposed).
- c. Notify unit maintenance if the refrigeration unit is to be put into administrative storage for several days.

2-8. DECALS AND INSTRUCTION PLATES.

Decals and instruction plates are illustrated in the following figure.

2-8. DECALS AND INSTRUCTION PLATES. - Continued

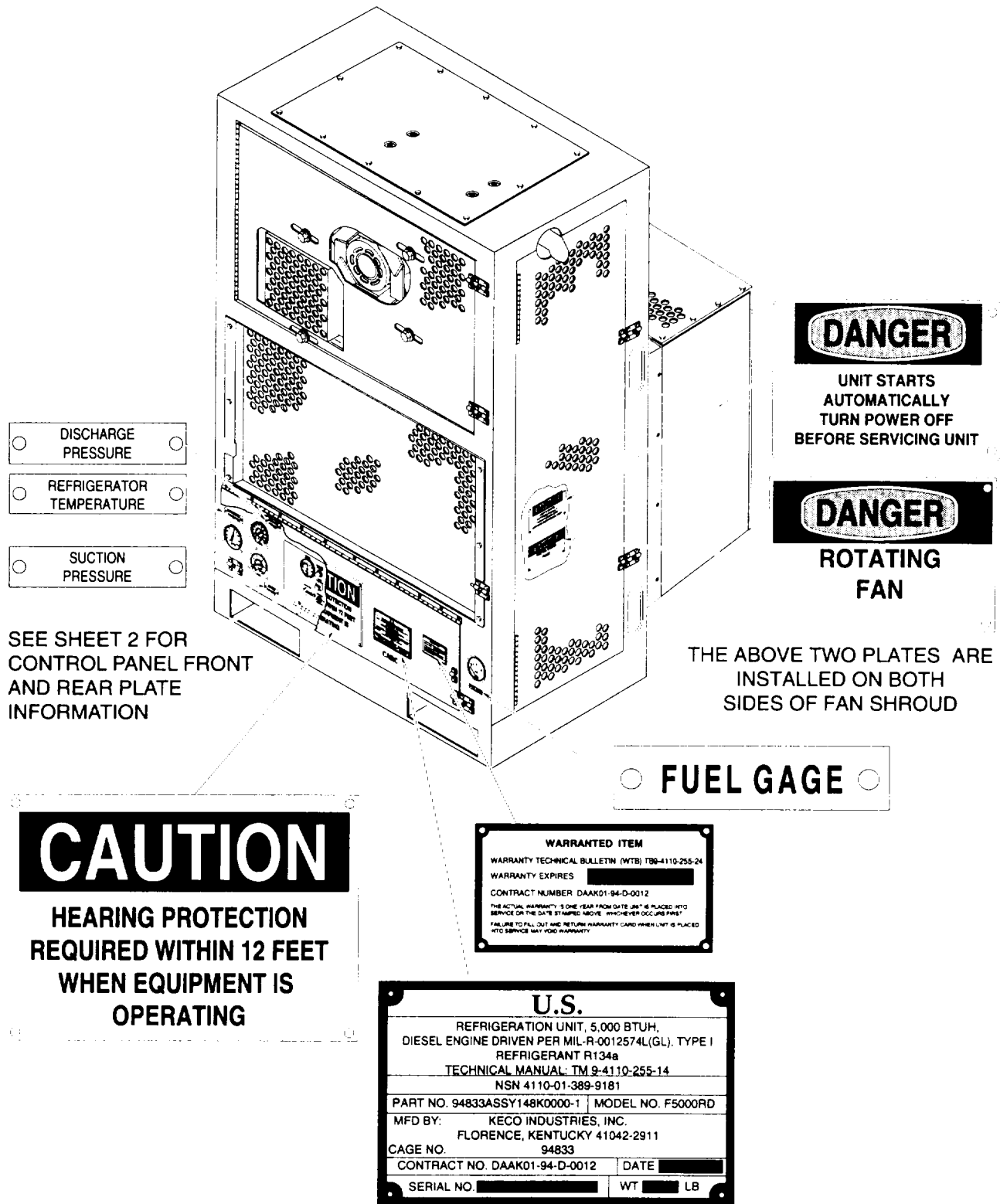
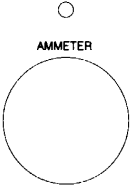



Figure 2-5. Decals and Instruction Plates (Sheet 1 of 2)

AMMETER



DEFROST IN PROGRESS



ENGINE FAULT RESET



START/RUN OFF



GLOWPLUG



HOURLMETER

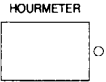

TEMPERATURE CONTROL



OPERATING INSTRUCTIONS

START

WARNING: PRIOR TO STARTING UNIT, CHECK:

- BOTH RECEIVER VALVES OPEN *
- HOT GAS LINE VALVE OPEN *
- DRIER OUTLET LINE VALVE OPEN *
- SUCTION SERVICE VALVE BACKSEATED AND CRACKED. *
- DISCHARGE SERVICE VALVE BACKSEATED AND CRACKED. *

1. SET TEMPERATURE CONTROL INSIDE CONTROL BOX AT REQUIRED TEMPERATURE TO BE MAINTAINED IN THE REFRIGERATOR.

2. TURN THE REFRIGERATION START/RUN-OFF-GLOWPLUG SWITCH TO "START/RUN".

OPERATION

1. AFTER THE START PROCEDURE, THE UNIT WILL START, STOP AND DEFROST AUTOMATICALLY WHILE MAINTAINING THE REQUIRED TEMPERATURE AS SET ON THE TEMPERATURE CONTROL.

SHUT DOWN

- TO STOP THE UNIT PLACE THE START/RUN-OFF-GLOWPLUG SWITCH TO "OFF".
- IF UNIT IS TO SHUT DOWN FOR SEVERAL DAYS, IT SHOULD BE "PUMPED DOWN" *

MAINTENANCE (DAILY)

- WHILE COMPRESSOR IS RUNNING, OBSERVE THE REFRIGERANT SIGHT GLASS. A CLEAR SIGHT GLASS IS NORMAL. CONSULT THE TECHNICAL MANUAL IF A CONTINUOUS BUBBLY OR MILKY SIGHT GLASS IS OBSERVED.
- OBSERVE THE COMPRESSOR OIL SIGHT GLASS IF THE OIL LEVEL IS NOT VISIBLE, CONSULT THE TECHNICAL MANUAL.
- CHECK THE ENGINE OIL LEVEL. REFILL AS REQUIRED.
- CHECK ALL BELTS FOR PROPER TENSION AND WEAR. ADJUST OR REPLACE AS REQUIRED.
- CHECK FUEL TANK LEVEL. REFILL IF REQUIRED.
- CHECK THE ENGINE FOR LOOSE CONNECTIONS, LEAKS, ETC. CORRECT AS NECESSARY. *
- INSPECT THE UNIT THROUGHOUT, MAINTAIN AND CLEAN AS REQUIRED.

MAINTENANCE (WEEKLY)

- CHECK THE EVAPORATOR CONDENSATE DRAIN FOR OBSTRUCTIONS, CLEAN AS REQUIRED.
- CHECK THE EVAPORATOR AND CONDENSER INLET GUARDS AND FINS FOR DIRT AND FOREIGN MATERIAL. CLEAN AS REQUIRED TO ALLOW FOR PASSAGE OF AIR.

MAINTENANCE (MONTHLY)

- LUBRICATE THE ENGINE, COMPRESSOR, GREASE FITTINGS, ETC. *

* SEE TECHNICAL MANUAL FOR RECO INDUSTRIES INC. MODEL FS600RD REFRIGERATION UNIT.

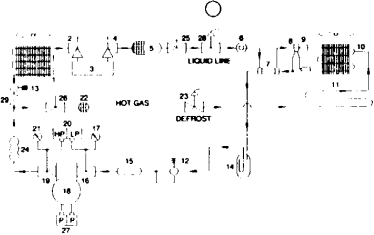

LEGEND:

- CONDENSER
- SHUT-OFF VALVE
- RECEIVER
- SHUT-OFF VALVE
- FILTER DRIER
- MOISTURE LIQUID INDICATOR
- HEAT EXCHANGER
- THERMOSTATIC EXPANSION VALVE
- DISTRIBUTOR
- EVAPORATOR
- DEFROST COIL
- CRANKCASE PRESSURE REGULATOR
- DISCHARGE PRESSURE REGULATOR
- SUCTION ACCUMULATOR
- VI BRATION ABSORBER
- SUCTION SERVICE VALVE
- COMPOUND GAGE
- COMPRESSOR, OPEN
- DISCHARGE SERVICE VALVE
- DUAL PRESSURE CUTOUT SWITCH
- HEAD PRESSURE GAGE
- STRAINER
- THERMOSTATIC EXPANSION VALVE (DEFROST/EQ.)
- EVAPORATOR
- SHUT-OFF VALVE
- SHUT-OFF VALVE
- DIFF. OIL PRESSURE SWITCH
- SOLENOID VALVE (AC LIQUID LINE)
- CHECK VALVE

CONTROL PANEL FRONT

AMMETER

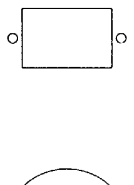

DEFROST IN PROGRESS



ENGINE FAULT RESET



START/RUN OFF



GLOWPLUG



HOURLMETER



PARTS		LEGEND	
AL1	PART OF SW	AL1	START/RUN OFF SWITCH
AL2	START/RUN OFF SWITCH	AL2	START/RUN OFF SWITCH
AL3	START/RUN OFF SWITCH	AL3	START/RUN OFF SWITCH
AL4	START/RUN OFF SWITCH	AL4	START/RUN OFF SWITCH
AL5	START/RUN OFF SWITCH	AL5	START/RUN OFF SWITCH
AL6	START/RUN OFF SWITCH	AL6	START/RUN OFF SWITCH
AL7	START/RUN OFF SWITCH	AL7	START/RUN OFF SWITCH
AL8	START/RUN OFF SWITCH	AL8	START/RUN OFF SWITCH
AL9	START/RUN OFF SWITCH	AL9	START/RUN OFF SWITCH
AL10	START/RUN OFF SWITCH	AL10	START/RUN OFF SWITCH
AL11	START/RUN OFF SWITCH	AL11	START/RUN OFF SWITCH
AL12	START/RUN OFF SWITCH	AL12	START/RUN OFF SWITCH
AL13	START/RUN OFF SWITCH	AL13	START/RUN OFF SWITCH
AL14	START/RUN OFF SWITCH	AL14	START/RUN OFF SWITCH
AL15	START/RUN OFF SWITCH	AL15	START/RUN OFF SWITCH
AL16	START/RUN OFF SWITCH	AL16	START/RUN OFF SWITCH
AL17	START/RUN OFF SWITCH	AL17	START/RUN OFF SWITCH
AL18	START/RUN OFF SWITCH	AL18	START/RUN OFF SWITCH
AL19	START/RUN OFF SWITCH	AL19	START/RUN OFF SWITCH
AL20	START/RUN OFF SWITCH	AL20	START/RUN OFF SWITCH
AL21	START/RUN OFF SWITCH	AL21	START/RUN OFF SWITCH
AL22	START/RUN OFF SWITCH	AL22	START/RUN OFF SWITCH
AL23	START/RUN OFF SWITCH	AL23	START/RUN OFF SWITCH
AL24	START/RUN OFF SWITCH	AL24	START/RUN OFF SWITCH
AL25	START/RUN OFF SWITCH	AL25	START/RUN OFF SWITCH
AL26	START/RUN OFF SWITCH	AL26	START/RUN OFF SWITCH
AL27	START/RUN OFF SWITCH	AL27	START/RUN OFF SWITCH
AL28	START/RUN OFF SWITCH	AL28	START/RUN OFF SWITCH
AL29	START/RUN OFF SWITCH	AL29	START/RUN OFF SWITCH
AL30	START/RUN OFF SWITCH	AL30	START/RUN OFF SWITCH
AL31	START/RUN OFF SWITCH	AL31	START/RUN OFF SWITCH
AL32	START/RUN OFF SWITCH	AL32	START/RUN OFF SWITCH
AL33	START/RUN OFF SWITCH	AL33	START/RUN OFF SWITCH
AL34	START/RUN OFF SWITCH	AL34	START/RUN OFF SWITCH
AL35	START/RUN OFF SWITCH	AL35	START/RUN OFF SWITCH
AL36	START/RUN OFF SWITCH	AL36	START/RUN OFF SWITCH
AL37	START/RUN OFF SWITCH	AL37	START/RUN OFF SWITCH
AL38	START/RUN OFF SWITCH	AL38	START/RUN OFF SWITCH
AL39	START/RUN OFF SWITCH	AL39	START/RUN OFF SWITCH
AL40	START/RUN OFF SWITCH	AL40	START/RUN OFF SWITCH
AL41	START/RUN OFF SWITCH	AL41	START/RUN OFF SWITCH
AL42	START/RUN OFF SWITCH	AL42	START/RUN OFF SWITCH
AL43	START/RUN OFF SWITCH	AL43	START/RUN OFF SWITCH
AL44	START/RUN OFF SWITCH	AL44	START/RUN OFF SWITCH
AL45	START/RUN OFF SWITCH	AL45	START/RUN OFF SWITCH
AL46	START/RUN OFF SWITCH	AL46	START/RUN OFF SWITCH
AL47	START/RUN OFF SWITCH	AL47	START/RUN OFF SWITCH
AL48	START/RUN OFF SWITCH	AL48	START/RUN OFF SWITCH
AL49	START/RUN OFF SWITCH	AL49	START/RUN OFF SWITCH
AL50	START/RUN OFF SWITCH	AL50	START/RUN OFF SWITCH
AL51	START/RUN OFF SWITCH	AL51	START/RUN OFF SWITCH
AL52	START/RUN OFF SWITCH	AL52	START/RUN OFF SWITCH
AL53	START/RUN OFF SWITCH	AL53	START/RUN OFF SWITCH
AL54	START/RUN OFF SWITCH	AL54	START/RUN OFF SWITCH
AL55	START/RUN OFF SWITCH	AL55	START/RUN OFF SWITCH
AL56	START/RUN OFF SWITCH	AL56	START/RUN OFF SWITCH
AL57	START/RUN OFF SWITCH	AL57	START/RUN OFF SWITCH
AL58	START/RUN OFF SWITCH	AL58	START/RUN OFF SWITCH
AL59	START/RUN OFF SWITCH	AL59	START/RUN OFF SWITCH
AL60	START/RUN OFF SWITCH	AL60	START/RUN OFF SWITCH
AL61	START/RUN OFF SWITCH	AL61	START/RUN OFF SWITCH
AL62	START/RUN OFF SWITCH	AL62	START/RUN OFF SWITCH
AL63	START/RUN OFF SWITCH	AL63	START/RUN OFF SWITCH
AL64	START/RUN OFF SWITCH	AL64	START/RUN OFF SWITCH
AL65	START/RUN OFF SWITCH	AL65	START/RUN OFF SWITCH
AL66	START/RUN OFF SWITCH	AL66	START/RUN OFF SWITCH
AL67	START/RUN OFF SWITCH	AL67	START/RUN OFF SWITCH
AL68	START/RUN OFF SWITCH	AL68	START/RUN OFF SWITCH
AL69	START/RUN OFF SWITCH	AL69	START/RUN OFF SWITCH
AL70	START/RUN OFF SWITCH	AL70	START/RUN OFF SWITCH
AL71	START/RUN OFF SWITCH	AL71	START/RUN OFF SWITCH
AL72	START/RUN OFF SWITCH	AL72	START/RUN OFF SWITCH
AL73	START/RUN OFF SWITCH	AL73	START/RUN OFF SWITCH
AL74	START/RUN OFF SWITCH	AL74	START/RUN OFF SWITCH
AL75	START/RUN OFF SWITCH	AL75	START/RUN OFF SWITCH
AL76	START/RUN OFF SWITCH	AL76	START/RUN OFF SWITCH
AL77	START/RUN OFF SWITCH	AL77	START/RUN OFF SWITCH
AL78	START/RUN OFF SWITCH	AL78	START/RUN OFF SWITCH
AL79	START/RUN OFF SWITCH	AL79	START/RUN OFF SWITCH
AL80	START/RUN OFF SWITCH	AL80	START/RUN OFF SWITCH
AL81	START/RUN OFF SWITCH	AL81	START/RUN OFF SWITCH
AL82	START/RUN OFF SWITCH	AL82	START/RUN OFF SWITCH
AL83	START/RUN OFF SWITCH	AL83	START/RUN OFF SWITCH
AL84	START/RUN OFF SWITCH	AL84	START/RUN OFF SWITCH
AL85	START/RUN OFF SWITCH	AL85	START/RUN OFF SWITCH
AL86	START/RUN OFF SWITCH	AL86	START/RUN OFF SWITCH
AL87	START/RUN OFF SWITCH	AL87	START/RUN OFF SWITCH
AL88	START/RUN OFF SWITCH	AL88	START/RUN OFF SWITCH
AL89	START/RUN OFF SWITCH	AL89	START/RUN OFF SWITCH
AL90	START/RUN OFF SWITCH	AL90	START/RUN OFF SWITCH
AL91	START/RUN OFF SWITCH	AL91	START/RUN OFF SWITCH
AL92	START/RUN OFF SWITCH	AL92	START/RUN OFF SWITCH
AL93	START/RUN OFF SWITCH	AL93	START/RUN OFF SWITCH
AL94	START/RUN OFF SWITCH	AL94	START/RUN OFF SWITCH
AL95	START/RUN OFF SWITCH	AL95	START/RUN OFF SWITCH
AL96	START/RUN OFF SWITCH	AL96	START/RUN OFF SWITCH
AL97	START/RUN OFF SWITCH	AL97	START/RUN OFF SWITCH
AL98	START/RUN OFF SWITCH	AL98	START/RUN OFF SWITCH
AL99	START/RUN OFF SWITCH	AL99	START/RUN OFF SWITCH
AL100	START/RUN OFF SWITCH	AL100	START/RUN OFF SWITCH

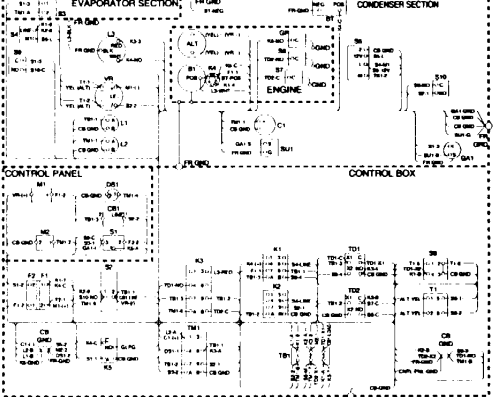

EVAPORATOR SECTION

CONDENSER SECTION

CONTROL PANEL

CONTROL BOX

CONTROL PANEL REAR

Figure 2-5. Decals and Instruction Plates (Sheet 2 of 2)

SECTION IV OPERATION UNDER UNUSUAL CONDITIONS**2-9. OPERATION UNDER INCLEMENT WEATHER**

The refrigeration unit is designed to operate under adverse environmental conditions such as rain, snow, etc. in temperatures from 0° F to 125° F (-17° C to 52° C). Follow the startup procedures given for usual conditions and apply the following procedures, as necessary, for operation in high temperatures (104° F to 125° F (45° C to 52° C)) and low temperatures (40° F to 0° F (4° C to -17° C)).

WARNING

- **Operating the refrigeration unit in a building or any enclosed area without the exhaust gases piped outside can result in serious illness or death.**
 - **The refrigeration unit engine produces dangerously high noise levels reaching 96 dB (A) at the service position. Approved hearing protection must be worn any time personnel are within 12 feet of an operating unit to avoid temporary or possibly permanent hearing damage.**
- a. Hot Weather (104° F to 125° F (45° C to 52° C)). Notify unit maintenance to drain and fill the engine with appropriate lubricating oil for hot weather.
 - b. Cold Weather (40° F to 50° F (4° C to -15° C)). Before placing the toggle switch (START/RUN, OFF, GLOWPLUG) (7, fig. 2-4) handle in the START/RUN position, place and hold in the GLOWPLUG position for 30 seconds.
 - c. Cold Weather (5° F to 0° F (-15° C to -17° C)).
 - (1) Notify unit maintenance to drain and fill the engine with appropriate lubricating oil for cold weather.
 - (2) Notify unit maintenance to drain and fill the fuel tank with appropriate fuel for cold weather.
 - (3) Before placing the toggle switch (START/RUN, OFF, GLOWPLUG) (7, fig. 2-4) handle in the START/RUN position, place and hold in the GLOWPLUG position for 30 seconds.

2-10. NBC DECONTAMINATION PROCEDURES.

The following emergency procedures can be performed until field NBC decon facilities are available. If NBC attack is known or suspected, mask at once and continue mission. If outside, follow decon procedures below to avoid taking contamination into controlled area. Do not unmask until told to do so.

NOTE

Detailed decontamination procedures can be found in: FM 3-3, FM 3-4, and FM 3-5.

- a. Nuclear Decontamination. Brush fallout from skin, clothing and equipment with available brushes, rags, and tree branches. Wash skin and have radiation check made when tactical situation permits.
- b. Biological Decontamination. Remain masked and continue mission until told to unmask.
- c. Chemical Detection and Decontamination.

WARNING

Some decontamination sprays can cause personal injury and should not be used on personnel.

(1) Contact your local chemical detachment or unit for proper use of decontamination equipment.

(2) If exposure to liquid agent is known or suspected, clean exposed skin, clothing, personal gear, and equipment, in that order, using M258A1 kit. Use the buddy system. Wash exposed skin and thoroughly decontaminate when tactical situation permits.

(3) Use M8 paper from the M256 Chemical Agent Detector Kit or M9 paper to determine if liquid agent is present on the equipment.

(4) If the M8 or M9 paper indicates that liquid chemical agent is present on the equipment, use the NBC-M11 decon apparatus to decon equipment.

CHAPTER 3

OPERATOR MAINTENANCE INSTRUCTIONS

		Page
SECTION I	LUBRICATION	3-1
	3-1 Lubrication	3-1
SECTION II	TROUBLESHOOTING PROCEDURES	3-1
	3-2 Troubleshooting.....	3-1
SECTION III	OPERATOR'S MAINTENANCE INSTRUCTIONS	3-5
	3-3 General	3-5
	3-4 Cleaning	3-6

SECTION I. LUBRICATION

3-1. LUBRICATION.

Operator lubrication not required.

SECTION II. TROUBLESHOOTING PROCEDURES

3-2. TROUBLESHOOTING.

The following procedures are listed in order of the most probable malfunctions. Each malfunction is followed by test or inspection procedures in logical order to isolate and identify the fault and actions required to correct it. This section cannot list all the possible malfunctions that may occur with the equipment. If a malfunction occurs that is not listed or actions listed do not correct a malfunction, notify your supervisor.

MALFUNCTION INDEX

	Troubleshooting Procedure Para
Engine does not start	3-2, a.
Thermometer (REFRIGERATOR TEMPERATURE) indicates more than 5° F above remote bulb thermostat (TEMPERATURE CONTROL) setting	3-2, b.
Pressure Gage (DISCHARGE PRESSURE) indicates above 250 psi (1725 kPa).....	3-2, c.
Pressure Gage (DISCHARGE PRESSURE) indicates below 165 psi (1138.5 kPa).....	3-2, d.
Compound Gage (SUCTION PRESSURE) indicates above 15 psi (103.5 kPa)	3-2, e.
Compound Gage (SUCTION PRESSURE) indicates below 0 psi (0 kPa).....	3-2, f.

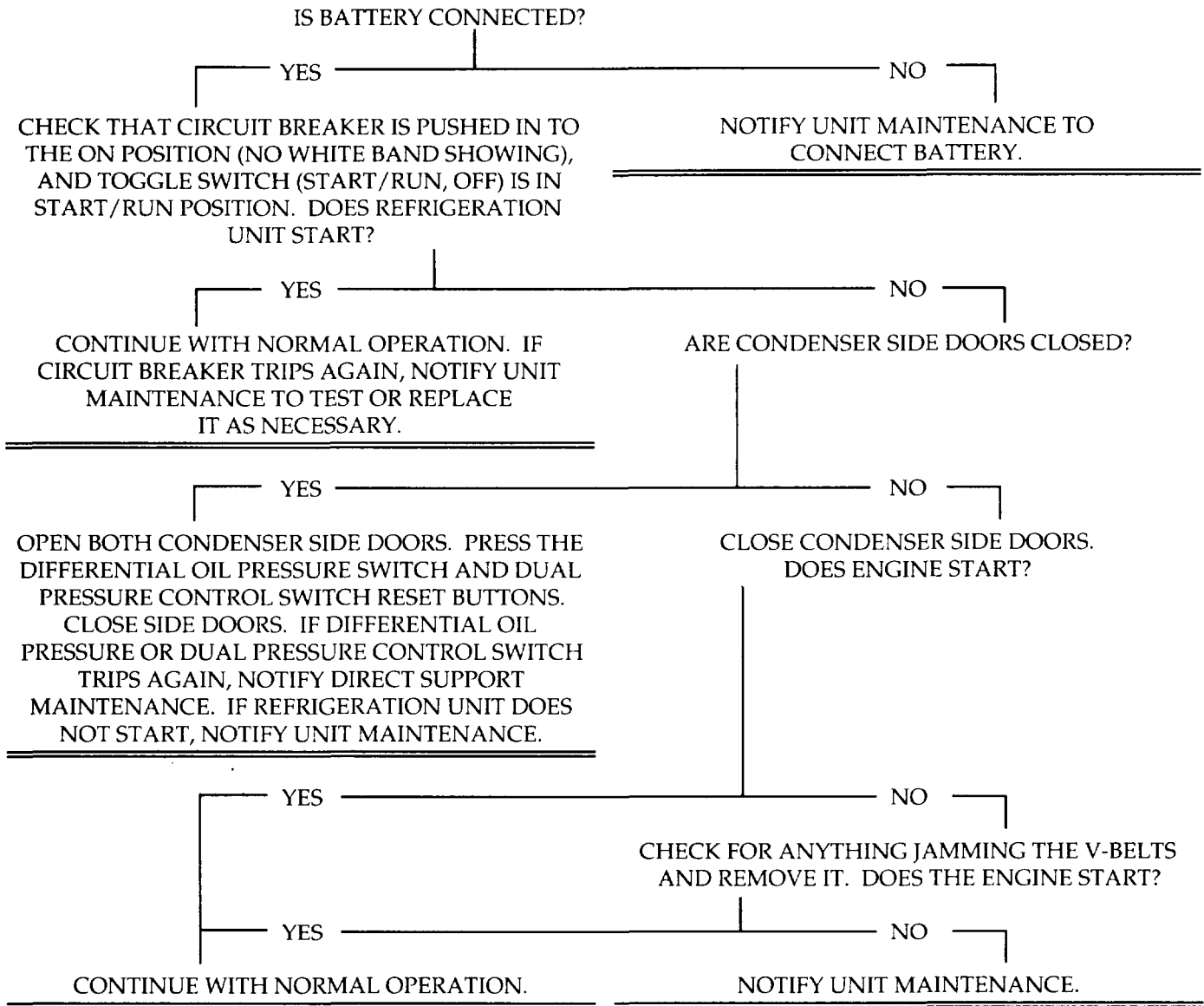

IS THE REFRIGERATION UNIT RUNNING?

YES

NO

CHECK READINGS ON PRESSURE AND COMPOUND GAGES. IF READINGS ARE ABOVE OR BELOW NORMAL OPERATING RANGE, SEE APPROPRIATE TROUBLE SHOOTING PROCEDURE. IF THE INDICATED TEMPERATURE IS STILL NOT WITHIN RANGE, NOTIFY UNIT MAINTENANCE.

START REFRIGERATION UNIT (PARA 2-5).

- c. Pressure Gage (DISCHARGE PRESSURE) Indicates Above 250 psi (1725 kPa). At start up and/or operation in high ambient temperatures, pressures above 250 psi (1725 kPa) are possible.

IS THE CONDENSER GUARD OBSTRUCTED?

YES

NO

SHUT DOWN THE REFRIGERATION UNIT (PARA 2-7) AND CLEAR THE OBSTRUCTION. IF OBSTRUCTION CANNOT BE CLEARED, NOTIFY UNIT MAINTENANCE TO CLEAR IT.

NOTIFY UNIT MAINTENANCE.

- d. Pressure Gage (DISCHARGE PRESSURE) Indicates Below 165 psi (1138.5 kPa). During operation in low ambient temperatures, pressures below 165 psi (1138.5 kPa) are possible.

NOTIFY UNIT MAINTENANCE.

- e. Compound Gage (SUCTION PRESSURE) Indicates Above 15 psi (103.5 kPa). At start up and/or operation in high ambient temperatures, pressures above 15 psi (103.5 kPa) are possible.

IS REFRIGERATOR ENCLOSURE DOOR OPEN?

YES

NO

CLOSE REFRIGERATOR ENCLOSURE DOOR.

NOTIFY UNIT MAINTENANCE.

- f. Compound Gage (SUCTION PRESSURE) Indicates Below 0 psi (0 kPa) At start up, shut down, or operation in low ambient temperatures, pressures below 0 psi (0 kPa) are possible.

IS THE EVAPORATOR COIL GUARD OBSTRUCTED?

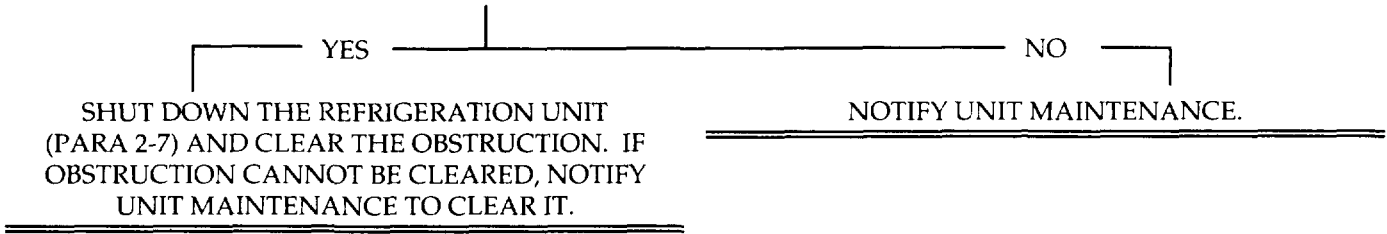

SECTION III. OPERATOR'S MAINTENANCE PROCEDURES

INDEX

	Para
ENCLOSURE	
General	3-3
Cleaning	3-4

3-3. GENERAL.

With the exception of service and inspection procedures noted in the PMCS table 2-1, the following maintenance procedure is the only one authorized to the operator.

3-4. CLEANING.

This task covers:

a. Pre-Inspection**b. Removal****c. Cleaning.****INITIAL SETUP**Materials/Parts:

Detergent
15, Appendix E

Rag
9, Appendix E

Equipment Conditions:

Refrigeration unit shut down (para 2-7).
Doors open as necessary.

General Safety Instructions:**WARNING**

Exposed rotating parts are contained in the refrigeration unit. Personal injury can result if not shut down.

Cleaning.

- (1) Mix a small quantity of detergent with clean water to make a wash solution.
- (2) Dampen a rag with wash solution and clean the equipment.
- (3) Dampen a rag with clean water and rinse the equipment. Rinse rag in clean water and continue until all detergent residue has been removed.
- (4) Wipe the equipment with a clean dry rag until thoroughly dry.

CHAPTER 4**UNIT MAINTENANCE INSTRUCTIONS****SECTION I REPAIR PARTS, TOOLS, SPECIAL TOOLS, TEST MEASUREMENT,
AND DIAGNOSTIC EQUIPMENT (TMDE), AND SUPPORT EQUIPMENT****4-1. COMMON TOOLS AND EQUIPMENT.**

a. For authorized common tools and equipment, refer to the Modified Table of Organization and Equipment (MTOE), CTA 50-970, or CTA 8-100, as applicable to your unit.

b. The Automotive Vehicle Shop Equipment (1) (SC 5180-90-CL-N18) tool kit will be used for all maintenance tasks. Any additional tools required for an individual maintenance task will be identified in the setup information for that task.

4-2. SPECIAL TOOLS, TMDE, AND SUPPORT EQUIPMENT.

a. The Repair Parts and Special Tools List (RPSTL) (TM 9-4110-255-24P) as well as the Maintenance Allocation Chart (MAC) (appendix B) identify any tools and support equipment needed to maintain the refrigeration unit.

b. There are no special or fabricated tools required to maintain the refrigeration unit.

4-3. REPAIR PARTS.

a. Any mandatory replacement parts needed for the maintenance tasks are identified in the mandatory replacement parts list located in Appendix G.

b. Repair parts are listed and illustrated in the repair parts and special tools list (TM 9-4110-255-24P) covering unit maintenance for this equipment.

SECTION II SERVICE UPON RECEIPT**4-4. SITE AND SHELTER REQUIREMENTS.**

a. The refrigerator enclosure must have an accessible wall area 35.0 in. (88 cm) wide and 56.5 in. (143.5 cm) high to accommodate the refrigeration unit and mounting angles.

b. The refrigeration unit weighs 800 lb (363 Kg). The refrigerator enclosure wall must be strong enough to support this weight.

4-5. SERVICE UPON RECEIPT OF MATERIAL.

a. Inspect the equipment for damage incurred during shipment. If the equipment has been damaged, report the damage on SF 364, Report of Discrepancy.

b. Check the equipment against the packing slip to see if the shipment is complete. Report all discrepancies in accordance with the instructions of DA Pam 738-750.

4-6. INSTALLATION INSTRUCTIONS.

a. Tools and Equipment Tools required to install the refrigeration unit include a wrench for tightening the mounting hardware and a fork lift or similar lifting device.

b. Refrigerator Enclosure Preparation The refrigerator enclosure must have an opening 30.50 inches (77.47 cm) wide and 28.00 inches (71.12 cm) high (fig. 4-1) to insert the refrigeration unit. If an opening does not already exist in the enclosure, see the enclosure manual for information on making such an opening.

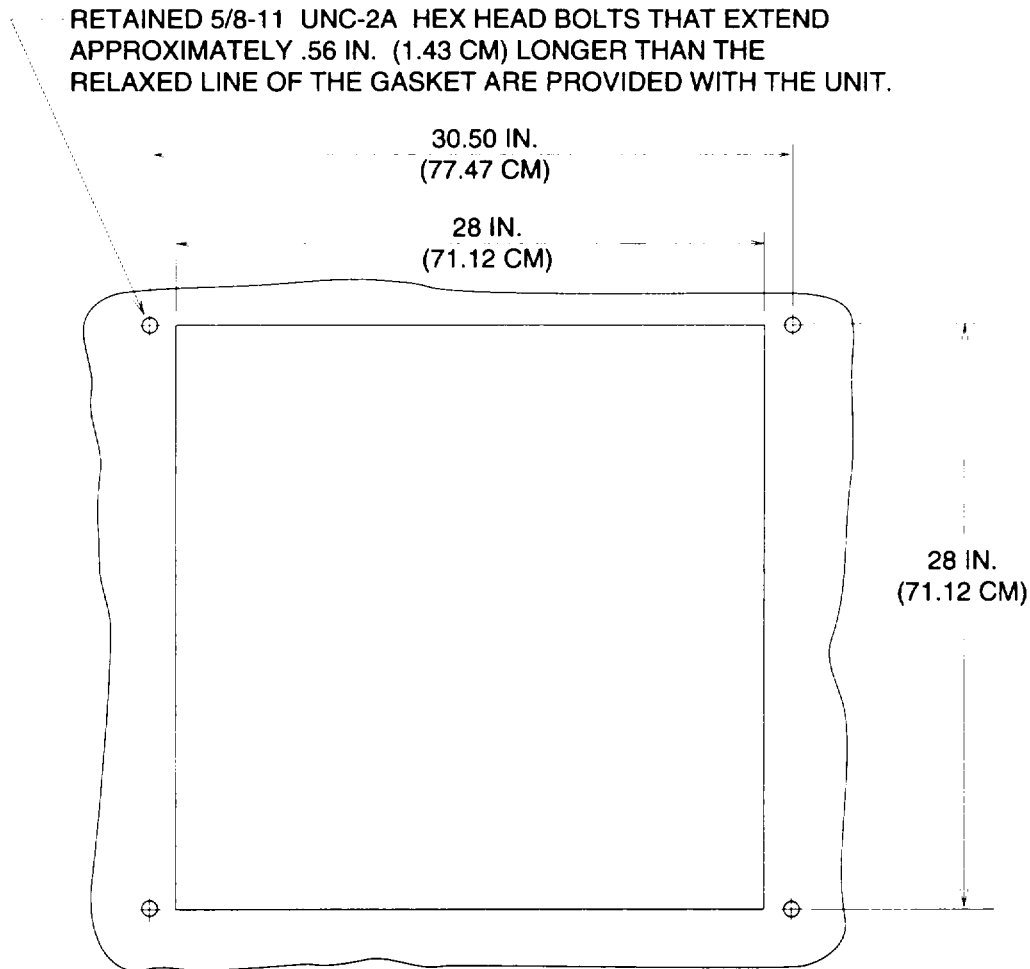

Figure 4-1. Wall Opening Dimensions

c. Installation. Using a fork lift or similar lifting device, lift the refrigeration unit and carefully position it into the refrigerator enclosure opening.

- (1) Secure the refrigeration unit to the refrigerator enclosure using mounting bolts provided.
- (2) Remove lifting device.

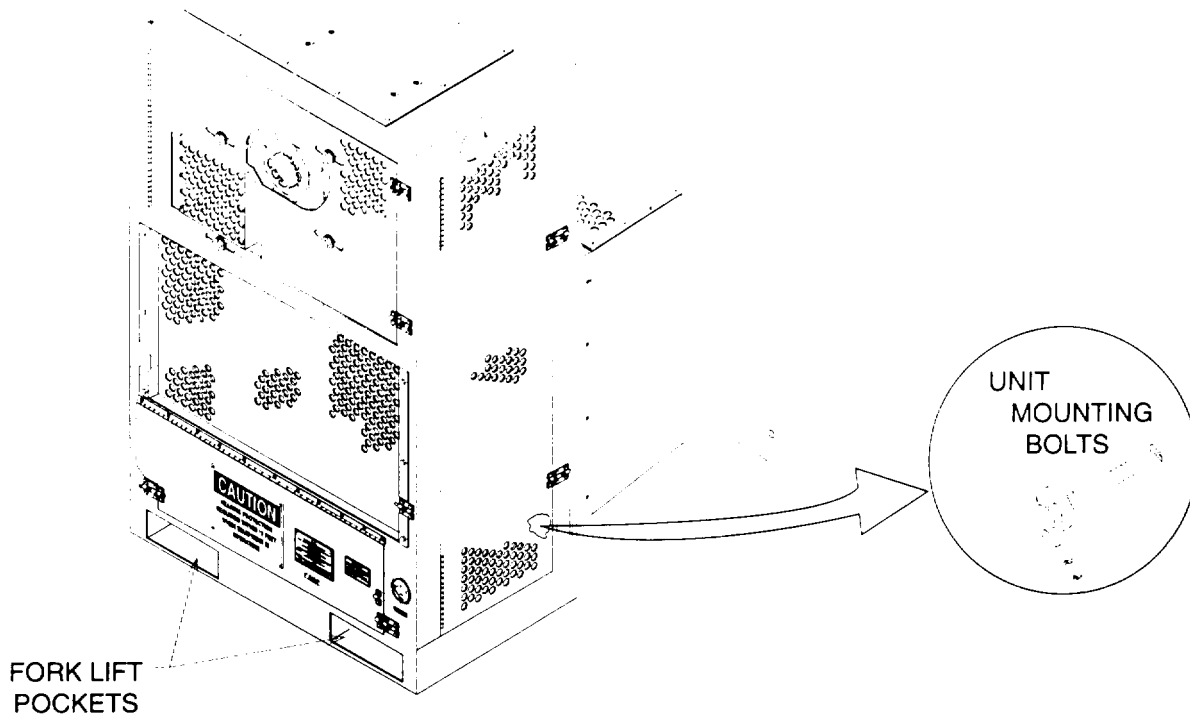

Figure 4-2. Installation

4-7. PRELIMINARY SERVICING OF EQUIPMENT.

- a. Open both side condenser doors and front door.
- b. Connect Battery Cables (para 4-35).
- c. Drain and Fill Fuel Tank. The fuel tank may contain residual fuel of questionable quality or preservative oil that must be removed before filling with fresh fuel.
 - (1) Place drain pan under shut-off cock (1, fig. 4-3).
 - (2) Loosen shut-off cock (1) and wait for all fuel or preservative oil to drain out. Contact your local environmental officer for guidance on how to properly dispose of fuel or preservative oil in accordance with local regulations.

4-7. PRELIMINARY SERVICING OF EQUIPMENT. - Continued

- (3) Tighten shut-off cock (1).

WARNING

•Splashes and spills of fuel can cause eye injury and skin irritation. Wear face shield and approved gloves when handling fuel. The full lever should remain below the base of the filler neck. Do not over fill.

•Immediately remove any articles of clothing or shoes that have become soaked with fuel. Stay in an area free from ignition sources until clothing has been removed.

- (4) Remove cap (2) and fill fuel tank (3) with 9 gal. (34 l) fuel (14, appendix E) if operating temperatures are 0° F to 50 F (-18° C to -15° C), or (13, appendix E) if operating temperatures are 5° F to 125° F (-15° C to 52° C).
- (5) Install cap (2).

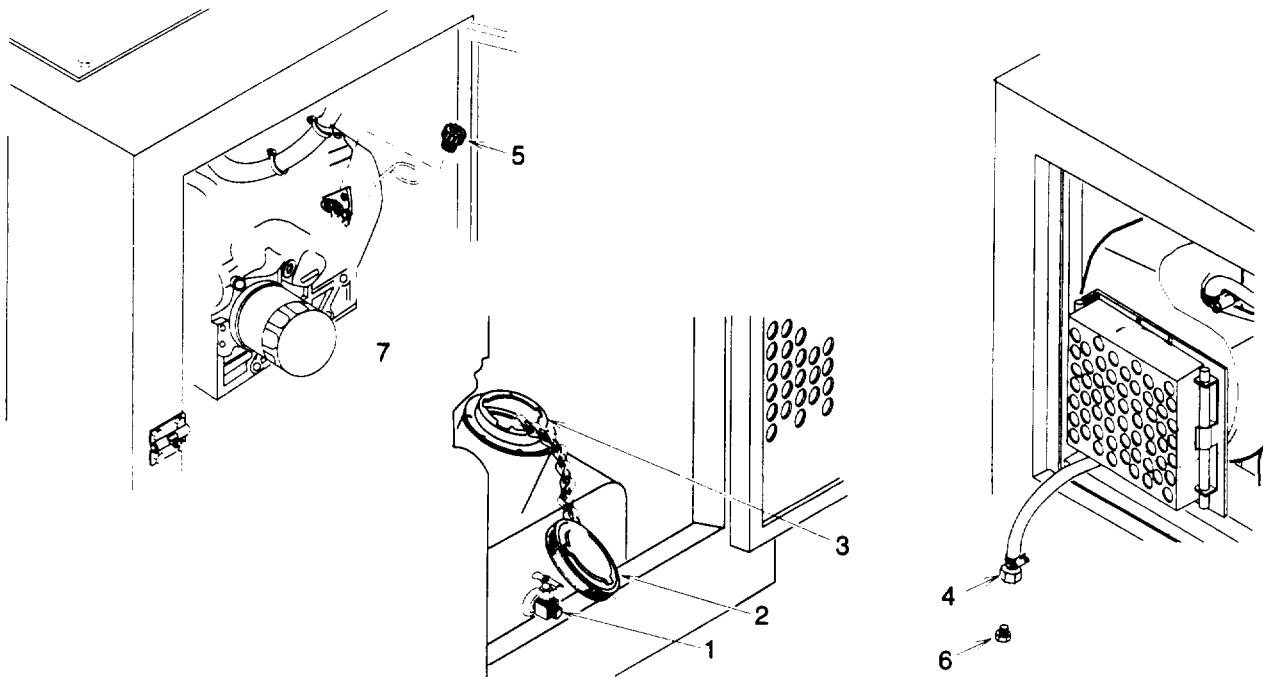

Figure 4-3. Unit Preparation

- d. Drain and Fill Engine Crankcase. The engine contains preservative oil that must be drained and replaced with the appropriate lubricating oil for the operating conditions.
- (1) Place drain pan under engine drain hose (4).
 - (2) Remove plug (5) and plug (6). Wait for all preservative oil to drain out. Contact your local environmental officer for guidance on how to properly dispose of preservative oil in accordance with local regulations.
 - (3) Clean plug (6) and drain hose (4) end with a wiping rag (3, appendix E) and install the plug.
 - (6) Fill engine (7) with 0.85 qt. (0.8 1) lubricating oil (11, appendix E) if operating temperatures are 0° F to 50 F (-18° C to -150 C), or (10, appendix E) if operating temperatures are 5° F to 1040 F (-15° C to 400 C), or (12, appendix E) if operating temperatures are 104° F to 1250 F (40° C to 520 C).
 - (7) Install plug (5).
- e. Check and adjust V-belts as necessary (para 4-38).

CAUTION

Using excessive force when opening or closing valves can cause damage to the valve seats.

- f. Refrigeration System Valves. The refrigeration system has been pumped down and the valves must be properly positioned before operating the refrigeration unit.
- (1) Fully open both stop valves (1, fig. 4-4) and (2).
 - (2) Remove two caps (3) and fully open two isolation valves (4). Install two caps.

NOTE

The compressor shut off valves can be adjusted to three positions, fully closed to block the refrigerant tubes and isolate the compressor and service port, fully open to allow flow from piping to compressor but not the service port, and cracked (one turn closed from fully open) to allow flow from piping to compressor and service port on valve.

- (3) Remove two caps (5) and fully open two shut off valves (6). Install two caps.
- g. Close both side condenser doors and front door.

4-8. PRELIMINARY ADJUSTMENT OF EQUIPMENT.

- a. Open control box cover and secure open with barrel bolt.
- b. Remove two bolts (1, fig. 4-5) and lock washers (2). Open the control box cover (3). Discard lock washers.

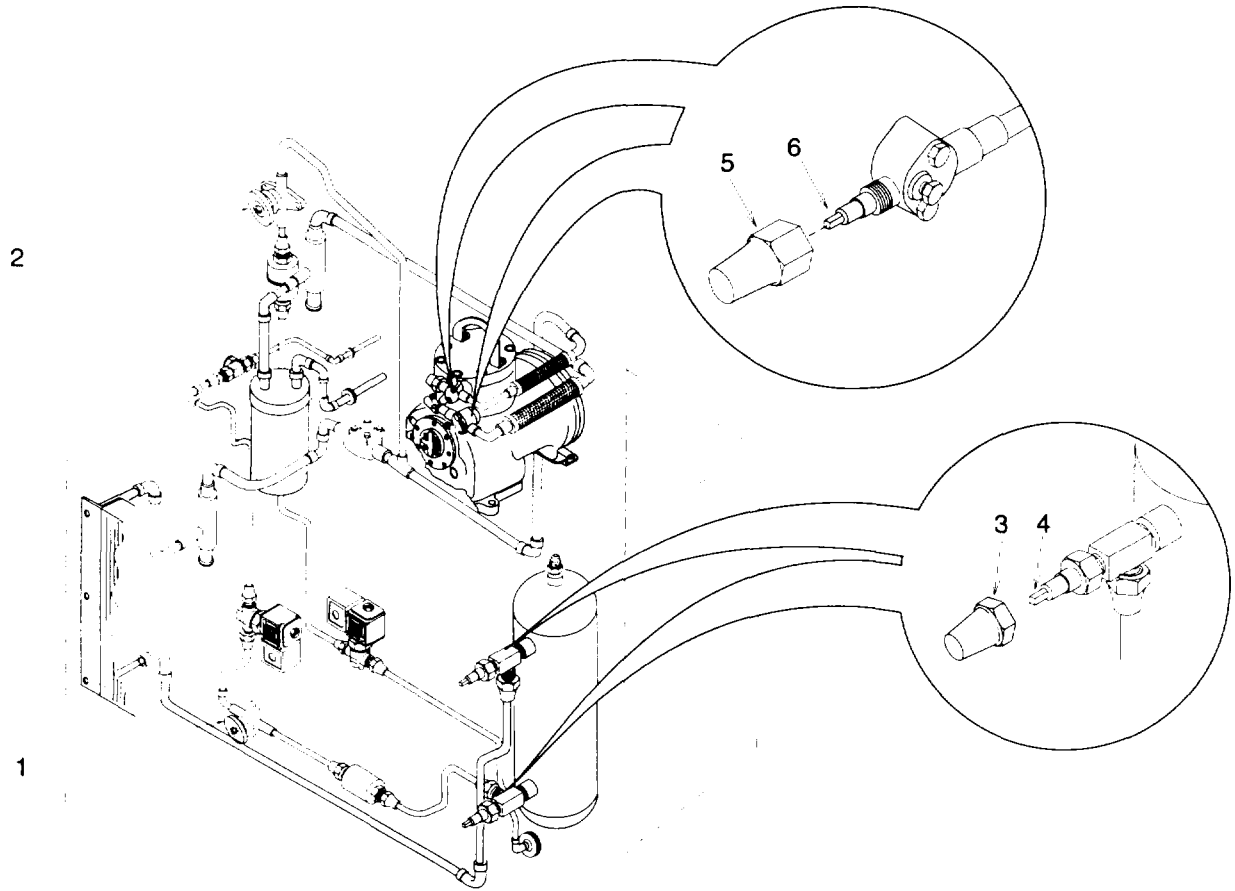

Figure 4-4. Refrigeration Valve Settings for Normal Operation

NOTE

- The repeat cycle timer controls are marked T1 and T2. Control T1 adjusts the length of time the refrigeration unit will operate continuously before initiating a defrost cycle. Control T2 adjusts the maximum length of time the refrigeration unit will remain in the defrost cycle.
 - The timer scales indicate an approximate percentage of time based upon a 24 hour cycle. For example, to set the timer for 6 hours, adjust the control to 25% (6 hours is 25% of 24 hours).
 - The timer controls have a minimum setting of 14 minutes when set at 0%.
- c. Adjust the repeat cycle timer (4) control T1 to approximately 25% (6 hours) and control T2 to approximately 2% (30 minutes). This is the recommended factory setting, however, the controls can be set as desired to best suit the operating conditions.
 - d. Close the control box cover (3). Install two new lock washers (2) (1, appendix G) and bolts (1).
 - e. Unlatch and close the control panel cover. Secure closed with barrel bolts.

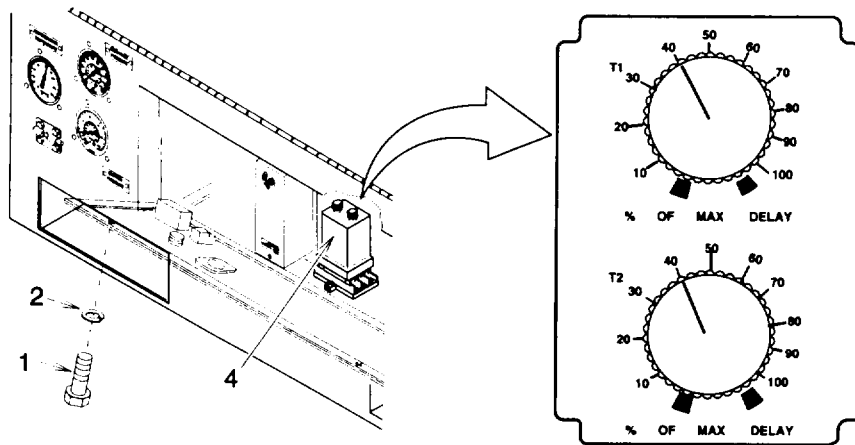

Figure 4-5. Defrost Timer Adjustment

SECTION III UNIT PREVENTIVE MAINTENANCE CHECKS AND SERVICES (PMCS)

4-9. LUBRICATION.

The lubrication instructions and hardtime intervals contained in Figure 4-6 are mandatory. This refrigeration unit is not enrolled in the Army Oil Analysis Program. HARDTIME INTERVALS APPLY.

4-10. GENERAL.

Preventive Maintenance Checks and Services (PMCS) are essential to the efficient operation of the refrigeration unit and to prevent possible damage that might occur through neglect or failure to observe warning symptoms in a timely manner. Intervals are determined by hours in operation expressed in applicable units of measure. The Preventive Maintenance Checks and Services Table 4-1 lists procedures done first or most frequently.

a. Warnings and Cautions. Always observe the warnings and cautions appearing in your PMCS Table. Warnings and cautions appear before applicable procedures. You must observe these warnings and cautions to prevent serious injury to yourself and others or prevent your equipment from being damaged.

b. Explanation of Table Entries.

(1) Item Number Column. Numbers in this column are for reference. When completing DA Form 2404 (Equipment Inspection and Maintenance Worksheet), include the item number for the check/service indicating a fault. Item numbers also appear in the order that you must do checks and services for the intervals listed.

(2) Interval Column. This column tells you when you must do the procedure in the procedure column. BEFORE procedures must be done before you operate or use the equipment for its intended mission. DURING procedures must be done during the time you are operating or using the equipment for its intended mission. AFTER procedures must be done immediately after you have operated or used the equipment. When a check and service procedure is required for both WEEKLY and BEFORE intervals, it is not necessary to do the procedure twice if the equipment is operating during the WEEKLY period.

(3) Location, Check/Service Column. This column provides the location and the item to be checked or serviced. The item location is underlined.

(4) Procedure Column. This column gives the procedure you must do to check or service the item listed in the Check/Service column to know if the equipment is ready or available for its intended mission or for operation. You must do the procedure at the time stated in the interval column.

(5) Not Fully Mission Capable If: Column. Information in this column tells you what faults will keep your equipment from being capable of performing its primary mission. If you made a check and service procedure that shows faults listed in this column, do not operate the equipment. Follow standard operating procedures for maintaining the equipment or reporting equipment failure.

FLANGE BEARING
(CONDENSER FAN)
LUBRICATION FITTING
(O)

LUBRICANT
GGP
INTERVAL
M

DOOR HINGE
(O)

OE/HDO-15/40

M

GUARD HINGE
(O)

OE/HDO-15/40

M

COVER HINGE
(O)

OE/HDO-15/40

M

BARREL BOLTS
(TWO EACH DOOR)
(O)

OE/HDO-15/40

M

DOOR HINGE
(TWO EACH DOOR)
(O)

OE/HDO-15/40

M

IDLER PULLEY
LUBRICATION FITTING
(O)

GGP

M

FLANGE BEARING
(EVAPORATOR FAN)
LUBRICATION FITTING
(O)

GGP

M

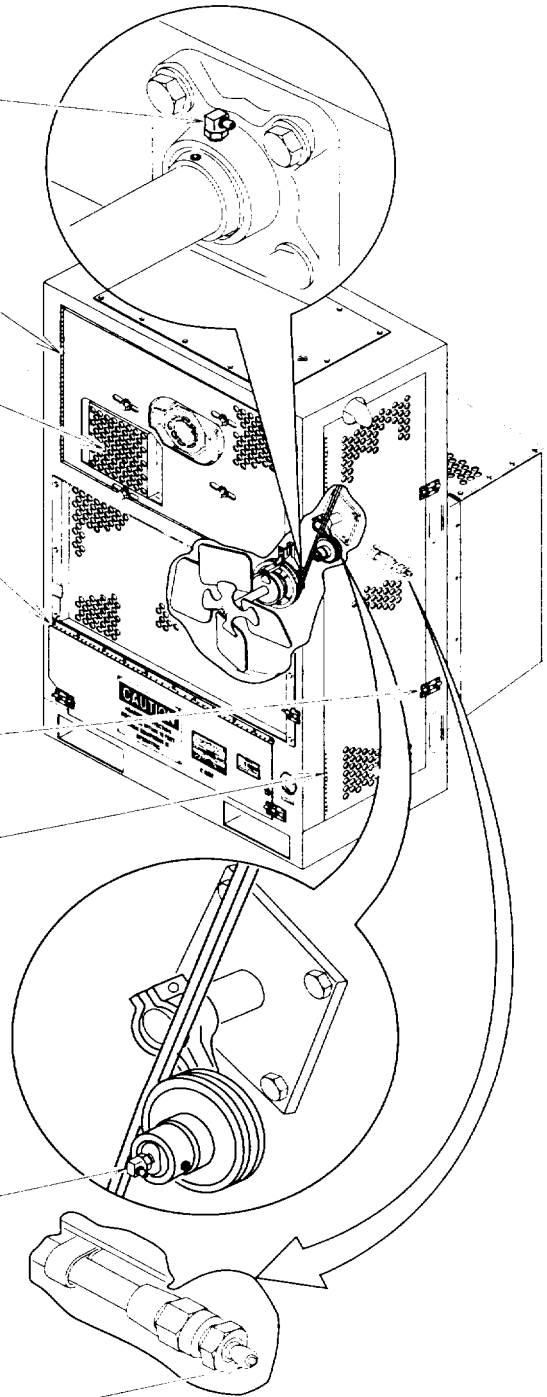

Figure 4-6. Lubrication (Sheet 1 of 2)

4-10. GENERAL. - Continued

ENGINE OIL
(O)

LUBRICANT
SEE LUBRICANT
TABLE

INTERVAL
SEE LUBRICANT
TABLE

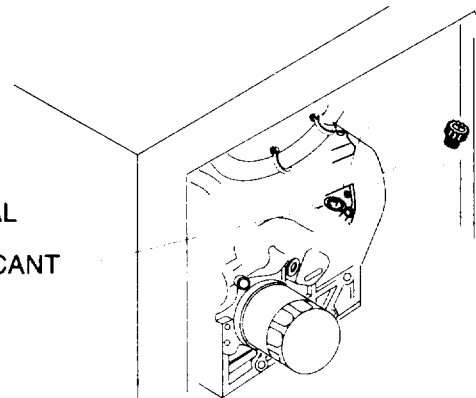

LUBRICANT TABLE

Temperature Range	Lubricant Mil. Symbol (NATO Code) Specification	Capacity	Interval	Man-hour
0° F to 5° F (-18° F to -15° C)	OE/HDO-10 (0-237) MIL-L-2104	0.85 qt (0.8 1)	50 H (initial break-in), 200 H (thereafter)	0.5
5° F to 104° F (-15° F to 40° C)	OE/HDO-15/40 (0-1236) MIL-L-2104	0.85 qt (0.8 1)	50 H (initial break-in), 200 H (thereafter)	0.5
104° F to 125° F (40° F to 52° C)	OE/HDO-50 (N/A) MIL-L-2104	0.85 qt (0.8 1)	50 H (initial break-in), 200 H (thereafter)	0.5

Figure 4-6. Lubrication (Sheet 2 of 2)

c. Special Information Paragraphs

(1) Corrosion Prevention Control. If a corrosion problem is identified, it can be reported using Standard Form 368, Production Quality Deficiency Report. The form should be submitted to the address specified in DA Pam 738750. This will result in more definitive actions be taken to prevent future occurrences.

(2) Leakage Definition for Unit PMCS. It is necessary for you to know how fluid leakage affects the status of your refrigeration unit. Oil is carried with the refrigerant as it flows through the refrigeration system. If a leak develops in the system, the oil will seep out and soak the copper tubing around the leak or drip and soak or puddle on the frame or other component below the leak. If any oil or seepage is found, a refrigerant leak would be suspected.

(a) Class I. Class I is defined as seepage of fluid (as indicated by wetness or discoloration) but not great enough to form drops.

(b) Class II. Class II is defined as leakage of fluid great enough to form drops but not enough to cause drops to drip from item being checked/inspected.

(c) Class III. Class III is defined as leakage of fluid great enough to form drops that fall from item being checked/inspected.

INITIAL SETUP

Tools:

Fin Comb
2, Section III, Appendix B

General Safety Instructions:

WARNING

Materials/ Parts:

Wiping Rag
9, Appendix E
Detergent
15, Appendix E
Lubricating Oil (Grade 15/40)
10, Appendix E
Lubricating Oil (Grade 10)
11, Appendix E
Lubricating Oil (Grade 50)
12, Appendix E
Multipurpose Grease
17, Appendix E

Exposed rotating parts are contained in the refrigeration unit. Personal injury can result if battery is connected with doors open.

Table 4-1. Unit Preventive Maintenance Checks and Services for Model F5000RD

NOTE

•If the equipment must be kept in continuous operation, do only the procedures that can be done without disturbing operation. Make complete checks and services when the equipment is shut down.

•The hourly intervals listed represent actual engine operation as indicated on the hourmeter.

Item No.	Interval	Location	Procedure	Not Fully Mission Capable If:
		Item to Check/Service		
1	8 Hours	Refrigeration Unit Interior	<p style="text-align: center;">NOTE</p> <p>The refrigeration unit must be shut down with the battery disconnected, the left side door, and front door must be open for all of the 8 hour PMCS.</p>	Air cleaner is missing or clogged.
		Air Cleaner		

Table 4-1. Unit Preventive Maintenance Checks and Services for Model F5000RD - Continued

Item No.	Interval	Location	Procedure	Not Fully Mission Capable If:
		Item to Check/Service		
2	8 Hours	Engine Oil	 <p>Service the engine oil by checking and refilling if necessary with appropriate oil (fig. 4-6).</p> <ol style="list-style-type: none"> a. Open left side door. b. Remove dipstick rod and wipe oil from end. Install and remove again. indicated is between minimum and maximum marks. Add oil if necessary. <ol style="list-style-type: none"> (1) Remove oil fill plug. (2) Add appropriate oil as necessary to bring level up to within minimum and maximum marks. (3) Install oil fill plug. c. Close front door and left side door. d. Connect battery (para 4-35) and put unit back into service. 	<p>Engine oil level is below minimum mark on dipstick rod.</p> <p>Check that oil level</p>

Table 4-1. Unit Preventive Maintenance Checks and Services for Model F5000RD - Continued

Item No.	Interval	Location	Procedure	Not Fully Mission Capable If:
		Item to Check/Service		
3	100 Hours	Engine Cooling Fins and Flywheel Vanes	 <p>Service the engine cooling fins and flywheel vanes by cleaning them using compressed air.</p> <ol style="list-style-type: none"> Shut down refrigeration unit (para 2-7) and disconnect battery (para 4-35). Open left side door, front door, and engine guard. Remove screw, flat washer, and casing. <p>WARNING Injury to personnel can result if compressed air used for cleaning purposes exceeds 30 psig (207 kPa). When using compressed air, wear safety glasses or goggles. Dirt can be blown into your eyes.</p> <ol style="list-style-type: none"> Using compressed air at 30 psig (207 kPa) or less, blow dirt out of cooling fins and flywheel vanes. Install casing, flat washer, and screw. Close engine guard, front door, and left side door. Connect battery (para 4-35) and put unit back into service. 	Cooling fins clogged.

Table 4-1. Unit Preventive Maintenance Checks and Services for Model F5000RD - Continued

Item No.	Interval	Location Item to Check/ Service	Procedure	Not Fully Mission Capable If:
4	200 Hours	Air Cleaner	 <p style="text-align: center;">NOTE The refrigeration unit must be shut down with the battery disconnected, both side doors, and front door must be open for all of the 200 hour PMCS.</p> <ol style="list-style-type: none"> a. Shut down refrigeration unit (para 2-7) and disconnect battery (para 4-35). b. Open both side doors and front door. c. Service the air cleaner by replacing it. <ol style="list-style-type: none"> (1) Loosen clamp and remove air cleaner. (2) Install clamp onto new air cleaner. (3) Install new air cleaner and tighten clamp. 	

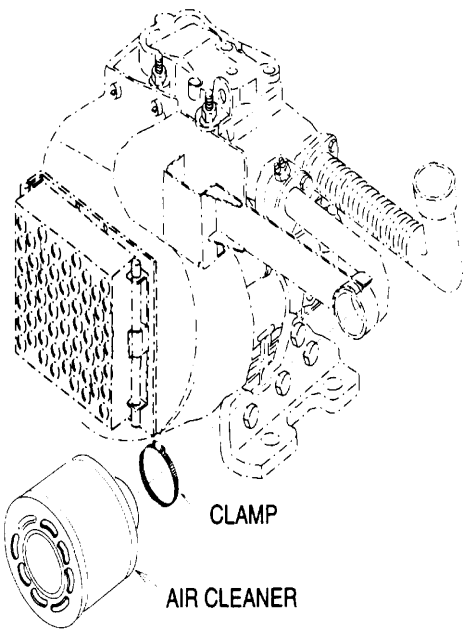
Table 4-1. Unit Preventive Maintenance Checks and Services for Model F500RD - Continued

Item No.	Interval	Location	Procedure	Not Fully Mission Capable If:
		Item to Check/Service		
5	200 Hours	Engine Oil	 <p>Service the engine oil by draining and refilling with appropriate oil (fig. 4-6).</p> <ol style="list-style-type: none"> Remove oil fill plug. Place drain pan under oil drain hose. Remove oil drain plug and allow oil to drain completely. Remove oil filter and seal. Discard seal. Contact your local environmental officer for guidance on how to properly dispose of used oil and oil filter in accordance with local regulations. Lubricate new seal with oil then install new seal and oil filter. 	

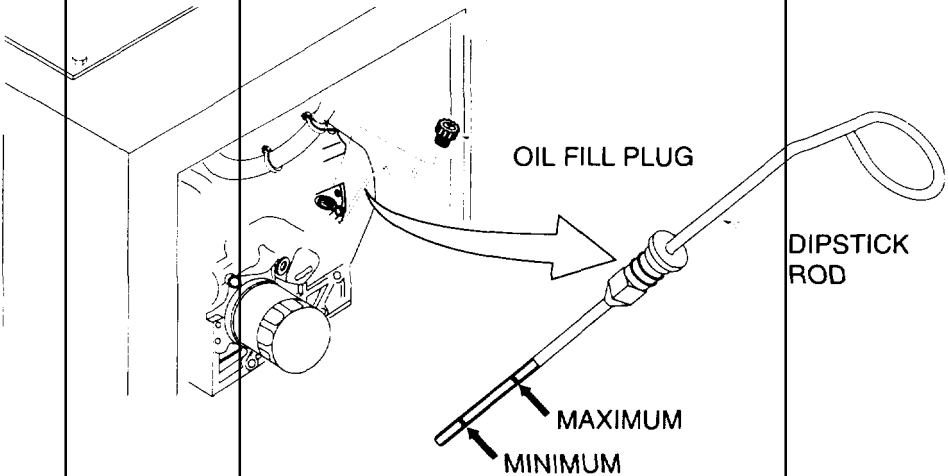
Table 4-1. Unit Preventive Maintenance Checks and Services for Model F5000RD - Continued

Item No.	Interval	Location	Procedure	Not Fully Mission Capable If:
		Item to Check/Service		
5 Cont			<p>g. Install oil drain plug and fill engine with appropriate grade and quantity of oil.</p> <p>h. Install oil fill plug.</p>	
6	200 Hours	Fuel Filters	Service the fuel filters by replacing them (para 4-56 and 4-64).	

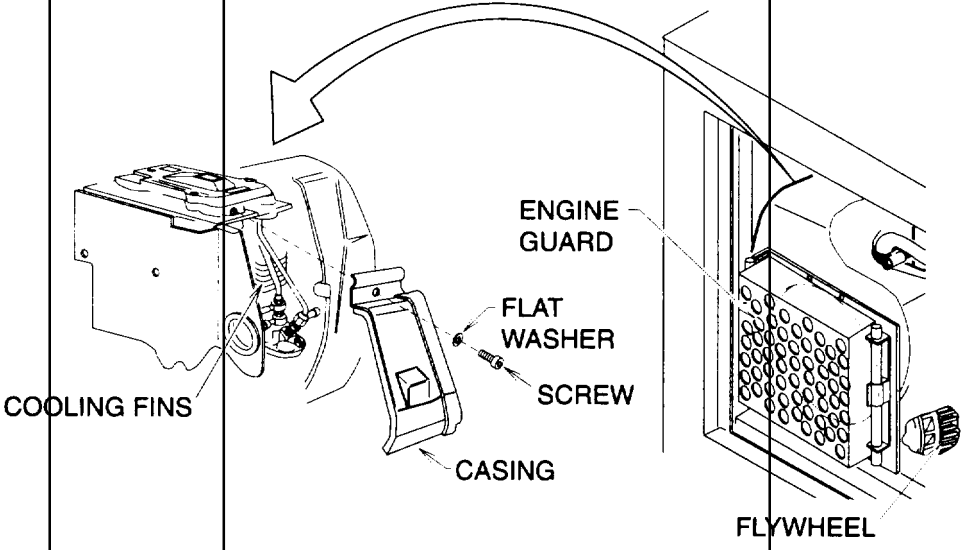
Table 4-1. Unit Preventive Maintenance Checks and Services for Model F5000RD - Continued

Item No.	Interval	Location Item to Check/ Service	Procedure	Not Fully Mission Capable If:
		 <p>FUEL FILTER</p>	 <p>IN-LINE FUEL FILTER</p>	
7	200 Hours	V-Belts	<p>Service the V-Belts by checking and adjusting tension as necessary (para 4-38).</p>  <p>V-BELTS V-BELT</p>	V-Belts are loose.

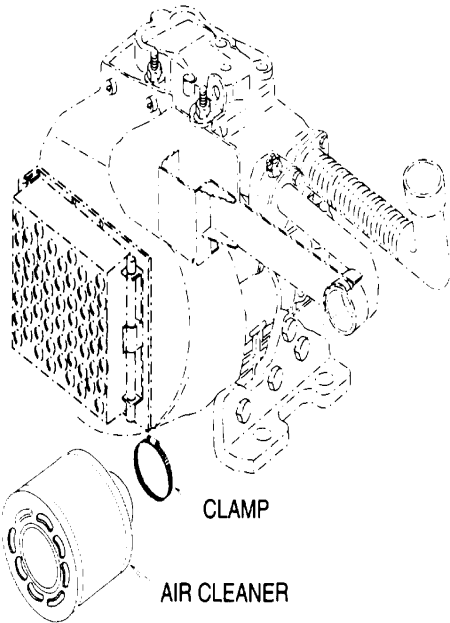
Table 4-1. Unit Preventive Maintenance Checks and Services for Model F5000RD - Continued

Item No.	Interval	Location	Procedure	Not Fully Mission Capable If:
		Item to Check/Service		
8	200 Hours	Engine Rocker arm	<p>Service the rocker arm by checking the clearance between the rocker arm and valve and adjusting if necessary.</p> <ol style="list-style-type: none"> Notify direct support maintenance to check and adjust the rocker arm to valve clearance as necessary. Close front door and both side doors. Connect battery (para 4-35) and put unit back into service. 	
9	500 Hours	Injector Nozzles	<p>Service the injector nozzles by removing, cleaning, and testing them.</p> <p>Notify direct support maintenance to clean and test the injector nozzles.</p>	Injector nozzles clogged. Notify direct support
10	500 Hours	Injection Pumps	<p>Service the injection pumps by testing and adjusting the injection timing. Notify direct support maintenance to test and adjust the injection pumps.</p>	Injection pumps out of time.
11	2500 Hours	Cylinder Head Valve Seats	<p>Service the valve seats by removing the cylinder head and testing them for air leaks.</p> <p>Notify direct support maintenance to remove the cylinder head and test the valve seats.</p>	Notify direct
12	5000 Hours	Engine	<p>The engine must be replaced with a new or rebuilt engine.</p>	Replace engine (para 4-61).
13	Monthly	Refrigeration Unit Exterior Doors/Cover	<p>Service the doors, guard, and cover by lubricating the hinges (fig. 4-6).</p> <ol style="list-style-type: none"> Apply lubricating oil (MIL-L-2104) sparingly from oil can onto the hinge moving joint surfaces. Wipe away excess lubricating oil with a clean rag. 	
14	Monthly	Barrel Bolts	<p>Service the barrel bolts by lubricating them (fig. 4-6).</p> <ol style="list-style-type: none"> Apply lubricating oil (MIL-L-2104) sparingly from oil can onto the barrel bolt moving joint surfaces. Wipe away excess lubricating oil with a clean rag. 	

Table 4-1. Unit Preventive Maintenance Checks and Services for Model F5000RD - Continued

Item No.	Interval	Location	Procedure	Not Fully Mission Capable If:
		Item to Check/Service		
15	Monthly	Condenser Coil	<p>a. Inspect as much of coil as possible, without disassembly, for any evidence of refrigerant leak. If evidence of leak is found, notify direct support maintenance to repair or replace it as necessary.</p> <p>b. Inspect coil for obstructions. If coil is obstructed with dirt or fins are bent, remove coil guard (para 4-14) and clean or straighten fins as needed.</p> <p>(1) Clean coil if dirty.</p> <p>(a) Mix a small quantity of detergent with water to make a wash solution.</p> <p>(b) Dip a scrub brush in the wash solution and clean the fins by carefully brushing up and down. Continue to dip and brush as needed to loosen dirt.</p> <p>(c) Rinse the scrub brush with clean water and rinse the fins by carefully brushing up and down. Continue to rinse and brush as needed to clean the coil.</p> <p>(2) If fins are bent, carefully straighten them using fin comb.</p> <p>(3) Install coil guard (para 4-14).</p>	Condenser coil is obstructed or evidence of leak is found.

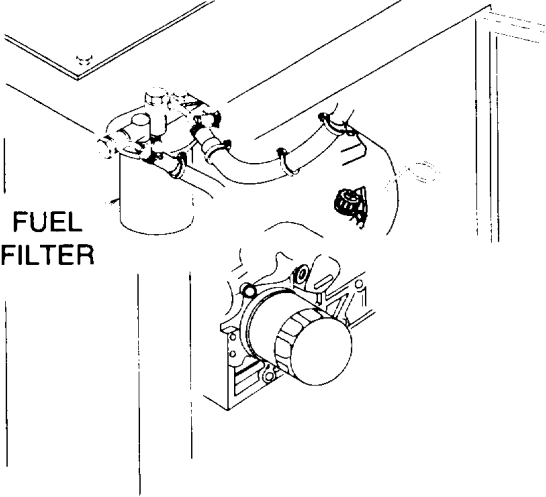
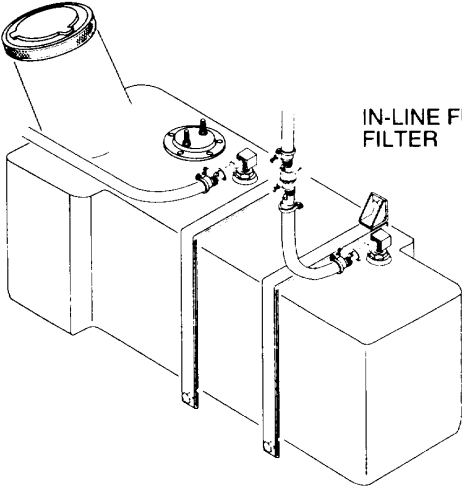
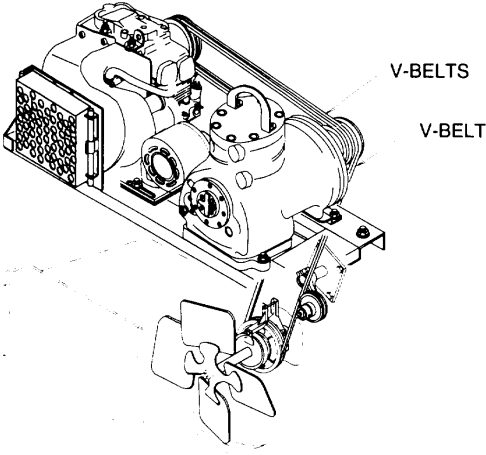
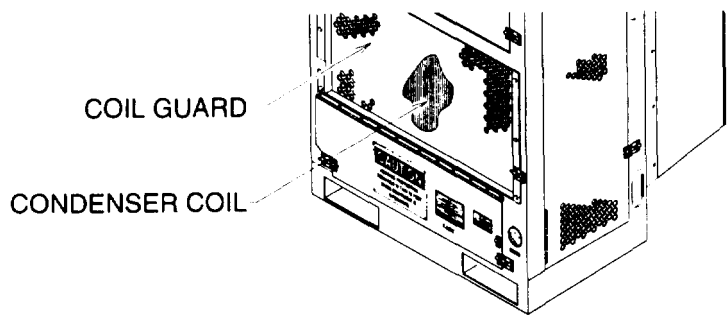

Table 4-1. Unit Preventive Maintenance Checks and Services for Model F5000RD - Continued

Item No.	Interval	Location	Procedure	Not Fully Mission Capable If:
		Item to Check/Service		
16	Monthly	Evaporator Coil	<p>a. Inspect as much of coil as possible, without disassembly, for any evidence of refrigerant leak. If evidence of leak is found, notify direct support maintenance to repair or replace it as necessary.</p> <p>b. Inspect coil for obstructions. If coil is obstructed with dirt or bent fins, remove cover panel (para 4-15) and clean or straighten fins as needed.</p> <p>(1) Clean coil if dirty.</p> <p>(a) Mix a small quantity of detergent with water to make a wash solution.</p> <p>(b) Dip a scrub brush in the wash solution and clean the fins by carefully brushing up and down. Continue to dip and brush as needed to loosen dirt.</p> <p>(c) Rinse the scrub brush with clean water and rinse the fins by carefully brushing up and down. Continue to rinse and brush as needed to clean the coil.</p> <p>(2) If fins are bent, carefully straighten them using fin comb.</p> <p>(3) Install cover panel (para 4-15).</p>	Evaporator coil is obstructed or evidence of leak is found.

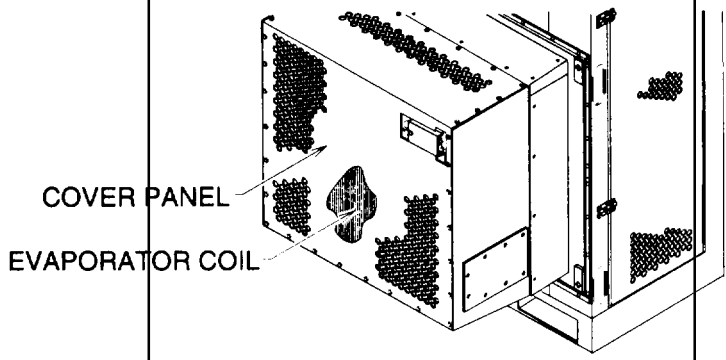

Table 4-1. Unit Preventive Maintenance Checks and Services for Model F5000RD - Continued

Item No.	Interval	Location	Procedure	Not Fully Mission Capable If:
		Item to Check/Service		
17	Monthly	Refrigeration Unit Interior	<p style="text-align: center;">NOTE</p> <p>The refrigeration unit must be shut down with the battery disconnected, both side doors must be open and cover panel must be removed for all of the monthly PMCS.</p> <p>a. Remove cover panel (para 4-15).</p> <p>b. Service the flange bearings and idler pulley by lubricating them (fig. 4-6).</p> <p>(1) Wipe lubrication fitting with a clean rag.</p> <p>(2) Pump grease gun handle until a flow of clean grease (MIL-G-23549) comes out nozzle.</p> <p>(3) Attach grease gun nozzle to lubrication fitting and pump handle until grease just begins coming out around bearing/idler pulley.</p> <p>(4) Remove grease gun nozzle and wipe away excess grease with a clean rag.</p> <p>c. Inspect flange bearings for loose or missing mounting hardware and looseness of fan drive shaft in bearing. If loose, tighten or replace it as necessary (para 4-43 or 4-44).</p> <p>d. Inspect idler pulley for looseness on shaft. If loose, tighten or replace it as necessary (para 4-40).</p>	Flange bearing mounts are loose or fan drive shaft is loose in bearing
		Flange Bearings and Idler Pulley		
18	Monthly	Condenser and Evaporator Fans	<p>a. Inspect fans for cracks and tears. Inspect for loose connection to fan drive shaft. If loose, tighten to shaft. If damaged, replace (para 4-41, 4-42).</p> <p>b. Install cover panel (para 4-15).</p>	Fan is cracked, torn, or loose.

Table 4-1. Unit Preventive Maintenance Checks and Services for Model F5000RD - Continued

Item No.	Interval	Location	Procedure	Not Fully Mission Capable If:
		Item to Check/Service		
19	Semi-Annually	Control Box Interior	 <p style="text-align: center;">NOTE</p> <p>The refrigeration unit must be shut down with the battery disconnected, both side doors and front door must be open, the control panel must be open, and the cover panel must be removed for all of the semi-annual PMCS.</p>	Wire lead or fuse clip loose. Fuse link is broken or fuse case is discolored.
		Fuses loose.		

Table 4-1. Unit Preventive Maintenance Checks and Services for Model F5000RD - Continued

Item No.	Interval	Location	Procedure	Not Fully Mission Capable If:
		Item to Check/Service		
20	Semi-Annually	Lamp Assembly	Inspect the lamp assembly for cracked or missing cap, loose base, and loose wire leads. Tighten cap if loose. If damaged, wire leads are loose, or base is loose, test, tighten base or wire leads, or replace as necessary (para 4-22).	Wire leads are loose.
21	Semi-Annually	Hourmeter	Inspect the hourmeter for cracked or missing lens or any other damage and loose or missing mounting hardware and wire leads. If damaged or wire leads or mounting hardware is loose, tighten, or replace as necessary (para 4-26).	Wire leads are loose.
22	Semi-Annually	Ammeter	Inspect the ammeter for cracked or missing lens or any other damage and loose or missing mounting hardware and wire leads. If damaged or wire leads or mounting hardware is loose, tighten, or replace as necessary (para 4-27).	Wire leads are loose.

Table 4-1. Unit Preventive Maintenance Checks and Services for Model F5000RD - Continued

Item No.	Interval	Location	Procedure	Not Fully Mission Capable If:
		Item to Check/Service		
23	Semi-Annually	Toggle Switch	Inspect the toggle switch for any damage and loose or missing mounting hardware or wire leads. Inspect for smooth operation to START/RUN, OFF, and GLOWPLUG positions. If damaged, or wire leads or mounting hardware is loose, or operation is stiff or binding, test, tighten, or replace as necessary (para 4-28).	Toggle switch will not stay in START/RUN or OFF position or stays in GLOWPLUG position. Wire leads are loose.
24	Semi-Annually	Circuit Breaker	Inspect the circuit breaker for any damage, secure mounting, or loose wire leads. Push to check for smooth operation to on (in, no white band showing) and off (out, white band showing). If damaged, mounting loose, wire leads loose, or operation is stiff or binding, test, secure, or replace as necessary (para 4-21).	Circuit breaker will not stay in on position or button is damaged. Wire leads are loose.
25	Semi-Annually	Control Relays	<p>a. Check for loose or missing mounting hardware and wire terminals. Tighten or replace as necessary (para 4-24).</p> <p>b. Inspect case for cracks, breaks, or evidence of overheating. Replace if damaged (para 4-24).</p>	Mounting hardware or wire terminals are loose. Case is damaged.
26	Semi-Annually	Time Delay Relays	<p>a. Check for loose or missing mounting hardware and wire terminals. Tighten or replace as necessary (para 4-25).</p> <p>b. Inspect case for cracks, breaks, or evidence of overheating. Replace if damaged (para 4-25).</p>	Mounting hardware or wire terminals are loose. Case is damaged.
27	Semi-Annually	Defrost Timer	<p>a. Check for loose or missing mounting socket hardware and wire terminals. Tighten or replace as necessary (para 4-29).</p> <p>b. Inspect case and mounting socket for cracks, breaks, or evidence of overheating. Replace if damaged (para 4-29).</p> <p>c. Check and adjust the timer controls if needed (para 4-8).</p>	Mounting hardware or wire terminals are loose. Case is damaged.
28	Semi-Annually	Remote Bulb Thermostat	<p>a. Check for loose or missing mounting hardware and wire terminals. Tighten or replace as necessary (para 4-30).</p> <p>b. Inspect for kinked or broken sensing bulb capillary line. If damaged, replace thermostat (para 4-30).</p>	Sensing bulb capillary line is kinked or broken. Mounting hardware or wire terminals are loose.

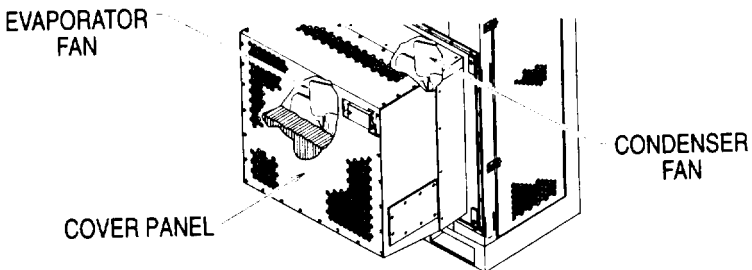
Table 4-1. Unit Preventive Maintenance Checks and Services for Model F5000RD - Continued

Item No.	Interval	Location	Procedure	Not Fully Mission Capable If:
		Item to Check/Service		
29	Semi-Annually	Engine Speed Switch	a. Check for loose or missing mounting hardware and wire terminals. replace as necessary (para 4-31). b. Inspect case for cracks, breaks, or evidence of overheating. Replace if damaged (para 4-31).	Mounting hardware or Tighten or wire terminals are loose. Case is damaged.
30	Semi-Annually	Control Transformer	a. Check for loose or missing mounting hardware and wire terminals. replace as necessary (para 4-32). b. Inspect case for cracks, breaks, or evidence of overheating. Replace if damaged (para 4-32).	Mounting hardware or Tighten or wire terminals are loose. Case is damaged. Replace if damaged
31	Semi-Annually	Continuous Duty Solenoid	a. Check for loose or missing mounting hardware and wire terminals. replace as necessary (para 4-34). b. Inspect case for cracks, breaks, or evidence of overheating. Replace if damaged (para 4-34). c. Close the control panel (para 4-19).	Mounting hardware or Tighten or wire terminals are loose. Case is damaged.
32	Semi-Annually	Refrigeration Unit Interior Defrost Termination Thermostat (Temperature Switch)	a. Inspect for frayed or broken wire leads. If damaged, repair or replace as needed (para 4-36). b. Check that the thermostat is in contact with the tubing. Tighten if loose.	Wire lead frayed or broken. Thermostat loose on tubing.

Table 4-1. Unit Preventive Maintenance Checks and Services for Model F5000RD - Continued

Item No.	Interval	Location	Procedure	Not Fully Mission Capable If:
		Item to Check/Service		
33	Semi-Annually	Heat Interchanger	Inspect the heat interchanger for dents or evidence of refrigerant leak. If damaged or dented or evidence of leaking found, notify direct support maintenance to replace it.	Heat interchanger is or evidence of leak is found.
34	Semi-Annually	Expansion Valve	<ol style="list-style-type: none"> a. Inspect the expansion valve for evidence of refrigerant leak. If evidence of leak is found, notify direct support maintenance to replace it. kinked or broken. b. Inspect the sensing bulb capillary line for cracks, kinks, or breaks. If damaged, notify direct support maintenance to replace the expansion valve. c. Check that the sensing bulb mounting hardware is secure and the bulb is in contact with the tubing. Tighten the mounting hardware if loose. 	Evidence of leak is found, sensing bulb is loose on tubing, or capillary line is

Table 4-1. Unit Preventive Maintenance Checks and Services for Model F5000RD - Continued

Item No.	Interval	Location	Procedure	Not Fully Mission Capable If:
		Item to Check/Service		
35	Semi-Annually	Tubing and Fittings	Inspect the tubing and fittings for kinks, restriction (crushed), or evidence of refrigerant leak. If damaged or evidence of leaking found, notify direct support maintenance to tighten, repair, or replace as necessary.	Tubing or fittings damaged, kinked, or evidence of leak is found.
36	Semi-Annually	Sending Unit unit.	<ol style="list-style-type: none"> Remove screws, lock washers and sending. Discard lock washers. Inspect sending unit for cracks or breaks. Check that the float arm moves freely and does not bind. If damaged or float arm binds, replace sending unit (para 4-66). Install sending unit and secure using new lock washers and screws. 	
				
37	Semi-Annually	Glow Plug	<ol style="list-style-type: none"> Remove nut, tag and remove wire lead. Remove glow plug. Inspect glow plug for damage to heater element such as swollen/split case or cracks. If damaged, replace glow plug. Install glow plug. Using tag and wiring diagram (fig. 1-4) install wire lead and nut. Remove tag. 	

Table 4-1. Unit Preventive Maintenance Checks and Services for Model F5000RD - Continued

Item No.	Interval	Location	Procedure	Not Fully Mission Capable If:
		Item to Check/Service		
38	Semi-Annually	Fuel Solenoid	<ol style="list-style-type: none"> a. Inspect fuel solenoid for damage such as dented case or evidence of overheating. If damaged, replace it (para 4-54). b. Install the cover panel (para 4-15). c. Close the control panel (para 4-19). d. Close front door and both side doors. e. Connect battery (para 4-35) and put unit back into service. 	Fuel solenoid damaged.

Table 4-1. Unit Preventive Maintenance Checks and Services for Model F5000RD - Continued

Item No.	Interval	Location	Procedure	Not Fully Mission Capable If:
		Item to Check/Service		
39	Annually			
		<p>Refrigeration Unit Interior</p> <p>NOTE</p> <p>The refrigeration unit must be shut down with the battery disconnected, both side doors and front door must be open, the control panel must be open, and the cover panel must be removed for all of the annual PMCS.</p>		
		Flywheel	<ol style="list-style-type: none"> a. Shut down refrigeration unit (para 2-7) and disconnect battery (para 4-35). b. Open both side doors and front door. c. Remove screws, flat washers, and shroud. d. Inspect flywheel for any damage such as cracks, broken or missing air vanes, or broken gear teeth. Notify direct support maintenance to replace it if damaged. e. Install shroud, flat washers, and screws. 	Flywheel is broken, cracked, or damaged.

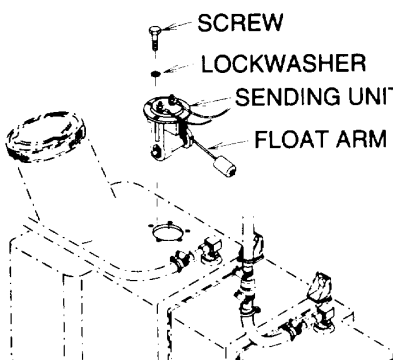
Table 4-1. Unit Preventive Maintenance Checks and Services for Model F5000RD - Continued

Item No.	Interval	Location Item to Check/ Service	Procedure	Not Fully Mission Capable If:
				

Table 4-1. Unit Preventive Maintenance Checks and Services for Model F5000RD - Continued

Item No.	Interval	Location	Procedure	Not Fully Mission Capable If:
		Item to Check/Service		
40	Annually	Wires, Cables, and Harnesses	<ul style="list-style-type: none"> a. Remove the cover panel (para 4-15). b. Open the control panel (para 4-19). c. Inspect for frayed or broken wire leads. If damaged, repair or replace as needed (para 4-19). d. Close the control panel (para 4-19). e. Install the cover panel (para 4-15). f. Close both side doors and front door. g. Connect battery (para 4-35) and put unit back into service. 	Wire lead frayed or broken.

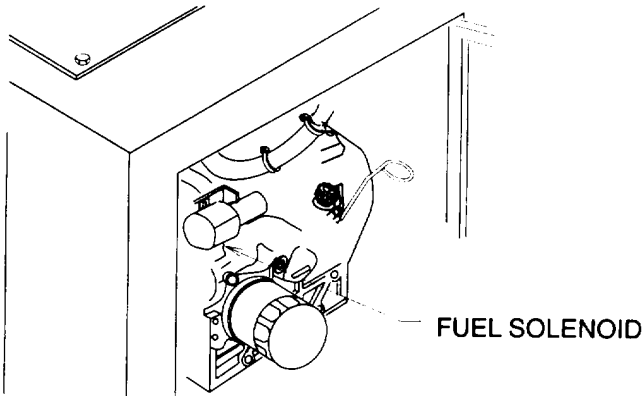
4-11. MANDATORY REPLACEMENT PARTS

The table below lists all items that must be replaced during PMCS whether they have failed or not. The table reflects the interval at which these items must be replaced whether hardtime maintenance or on condition maintenance is the determining factor.

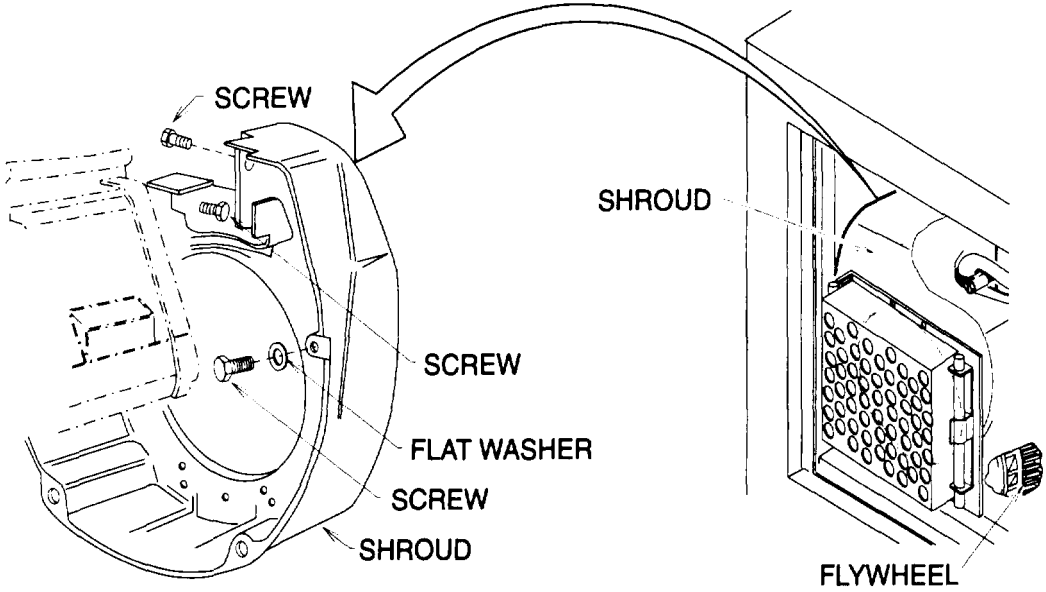
Table 4-2. 200 Hour Mandatory Replacement Parts

<u>Item No.</u>	<u>Part Number</u>	<u>National Stock Number</u>	<u>Nomenclature</u>	<u>Qty</u>
1	ECD06-5003 (18265)		Air Cleaner	1
2	771-7524 (62445)		Oil Filter	1
3	17520 (62445)		Fuel Filter	1
4	000-477-0015		In-line Fuel Filter	1

Table 4-3. Semi-Annually Mandatory Replacement Parts

<u>Item No.</u>	<u>Part Number</u>	<u>National Stock Number</u>	<u>Nomenclature</u>	<u>Qty</u>
1	500K1950-3 (94833)		Lock Washer	5

SECTION IV. UNIT TROUBLESHOOTING INSTRUCTIONS

4-12. TROUBLESHOOTING.

The following procedures are listed in order of the most probable malfunctions. Each malfunction is followed by test or inspection procedures in logical order to isolate and identify the fault and actions required to correct it. This section cannot list all the possible malfunctions that may occur with the equipment. If a malfunction occurs that is not listed or actions listed do not correct a malfunction, notify your supervisor.

a. Engine Does Not Crank

TEST BATTERY (PARA 4-35) AND REPLACE IF NEEDED. DOES REFRIGERATION UNIT START?

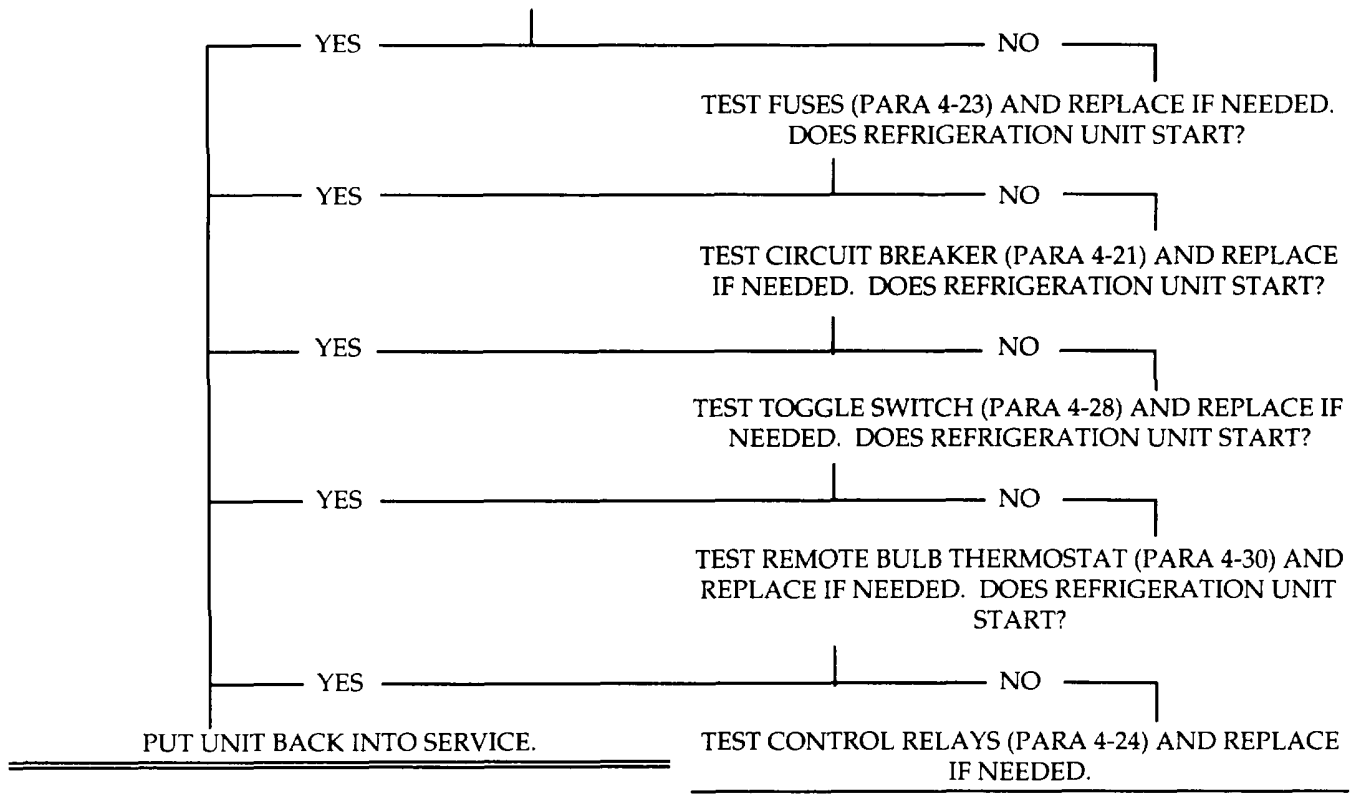

b. Engine Cranks But Will Not Start Or Stops During Operation.

CHECK FUEL LEVEL AND FILL IF NEEDED. DOES ENGINE START/RUN?

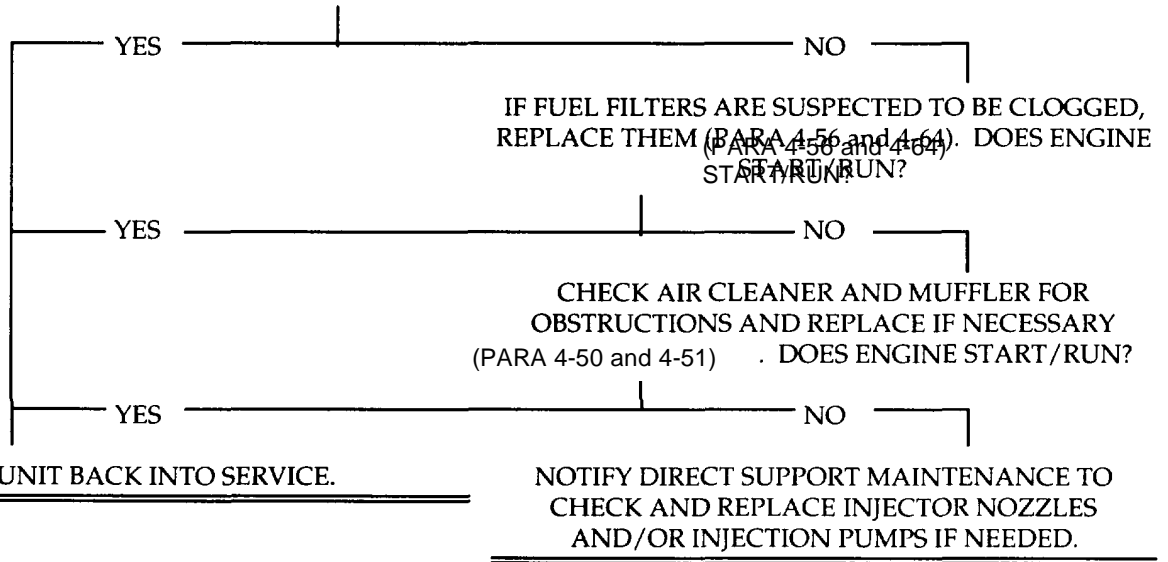

c. Engine Knocks When Operating

CHECK ENGINE OIL LEVEL AND FILL IF NEEDED. DOES ENGINE STILL KNOCK?

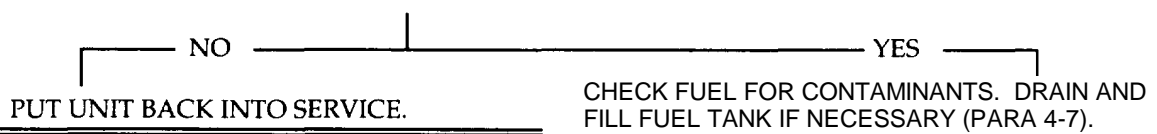

4-12. TROUBLESHOOTING. - Continued

d. Temperature Gage Indicates More Than 15° F (8° C) Above or Below Remote Bulb Thermostat Setting

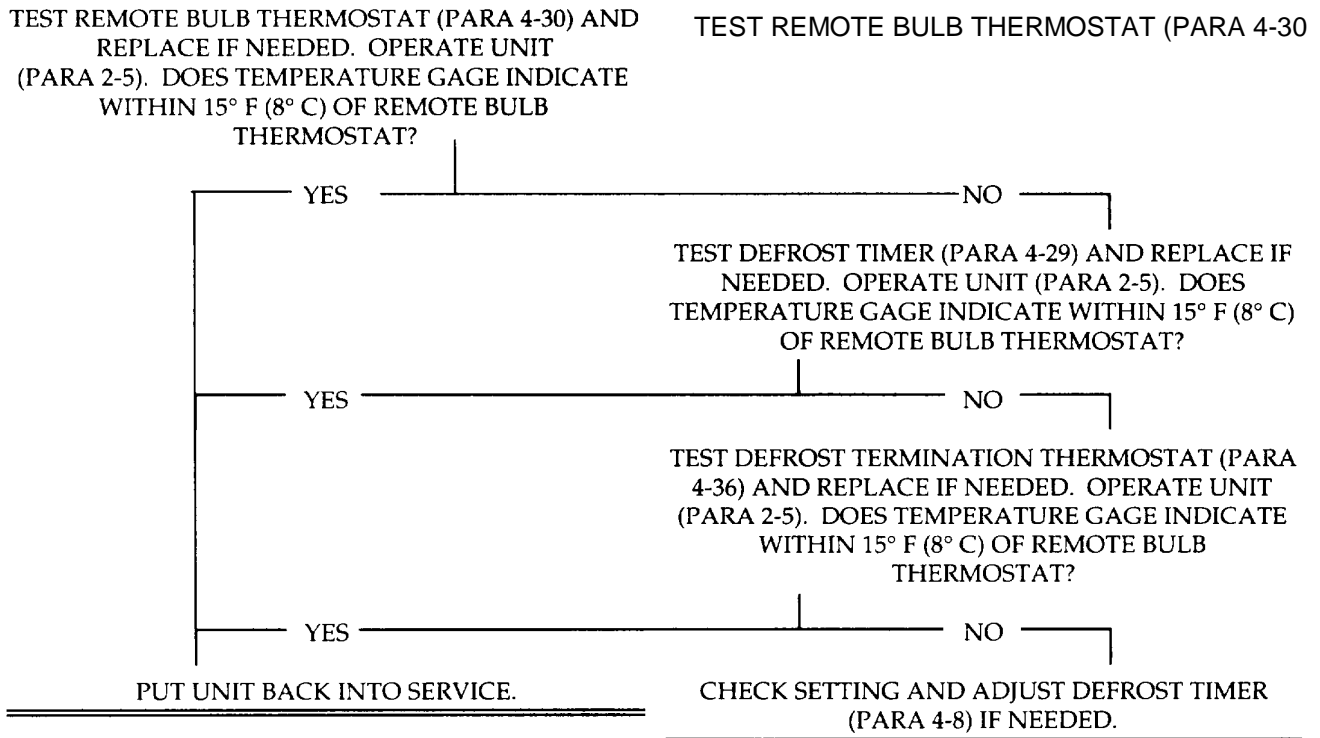

e. Pressure Gage Indicates Above 250 psi (1725 kPa).

OPEN ALL REFRIGERATION VALVES (PARA 4-7). IF ANY VALVES WERE CLOSED, OPERATE UNIT (PARA 2-5). IS PRESSURE GAGE BELOW 250 PSI (1725 kPa)?

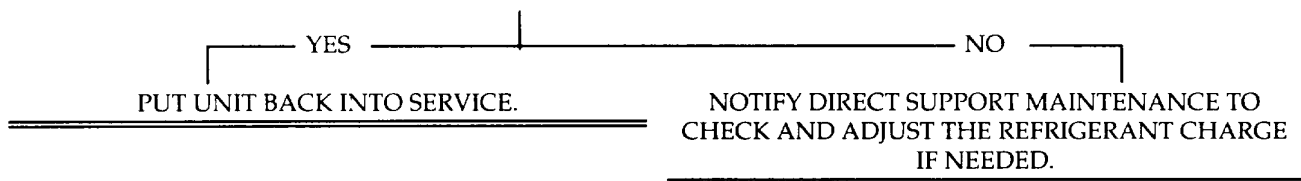

f. Pressure Gage Indicates Below 165 psi (1139 kPa).

OPEN ALL REFRIGERATION VALVES (PARA 4-7). IF ANY VALVES WERE CLOSED, OPERATE UNIT (PARA 2-5). IS PRESSURE GAGE ABOVE 165 PSI (1139 kPa)?

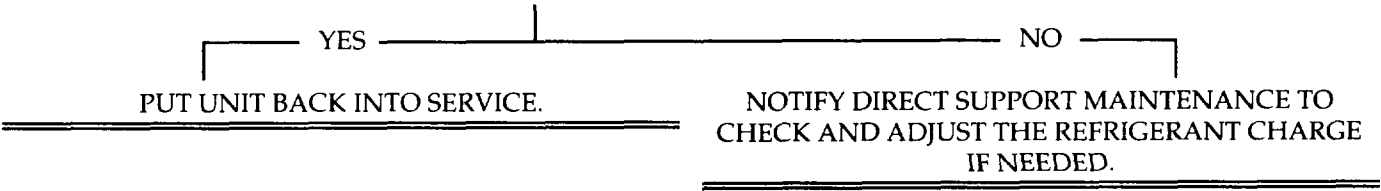

g. ~~Compound Gage Indicates Above 15 psi (103 kPa).~~

OPEN ALL REFRIGERATION VALVES (PARA 4-7). IF ANY VALVES WERE CLOSED, OPERATE UNIT (PARA 2-5). IS COMPOUND GAGE BELOW 15 PSI (103 kPa)?

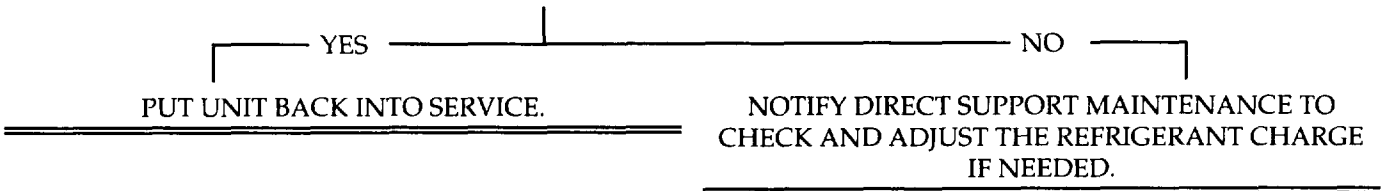

h. Compound Gage Indicates Below 0 psi (0kPa).

OPEN ALL REFRIGERATION VALVES (PARA 4-7). IF ANY VALVES WERE CLOSED, OPERATE UNIT (PARA 2-5). IS COMPOUND GAGE ABOVE 0 PSI (0 kPa)?

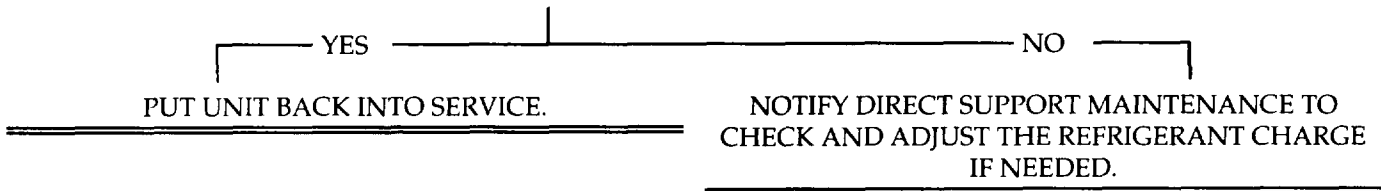

SECTION V UNIT MAINTENANCE INSTRUCTIONS

4-13. TOP ACCESS PANEL REPLACEMENT.

 This task covers:

a. Removal

b. Installation

INITIAL SETUPMaterials/Parts:

Lock Washers (12)
 1, Appendix G
 Lock Washers (4)
 2, Appendix G

Equipment Conditions:

Refrigeration unit shut down (para. 2-7).

General Safety Instructions:**WARNING**

Exposed rotating parts are used in the refrigeration unit. Personal injury can result if battery is connected.

a. Removal.

- (1) Remove four bolts (1), and lock washers (2). Discard lock washers.
- (2) Remove 12 bolts (3), lock washers (4), and panel (5). Discard lock washers.

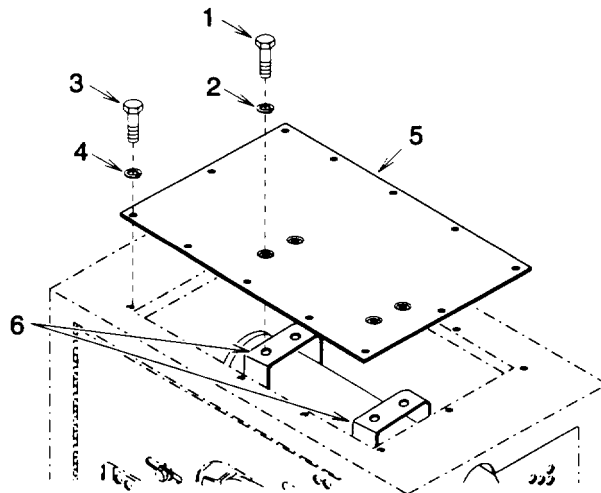

Figure 4-7. Top Panel

b. Installation.

- (1) Install top access panel (5).
- (2) Aline muffler brackets (6) with top access panel (5), and install four new lock washers (2) and bolts (1).
- (3) Install 12 new lock washers (4), and bolts (3).

NOTE

FOLLOW-ON MAINTENANCE:
Connect battery (para. 4-35) and put unit back into service.

4-14. FRONT COIL GUARD PANEL REPLACEMENT.

This task covers:

a. Removal

b. Installation

INITIAL SETUPMaterials/Parts:

Lock Washers (6)
1, Appendix G

- a. Removal. Remove six bolts (1), flat washers (2), lock washers (3), and front coil guard panel (4). Discard lock washers.
- b. Installation. Install front coil guard panel (4), six flat washers (2), new lock washers (3), and bolts (1).

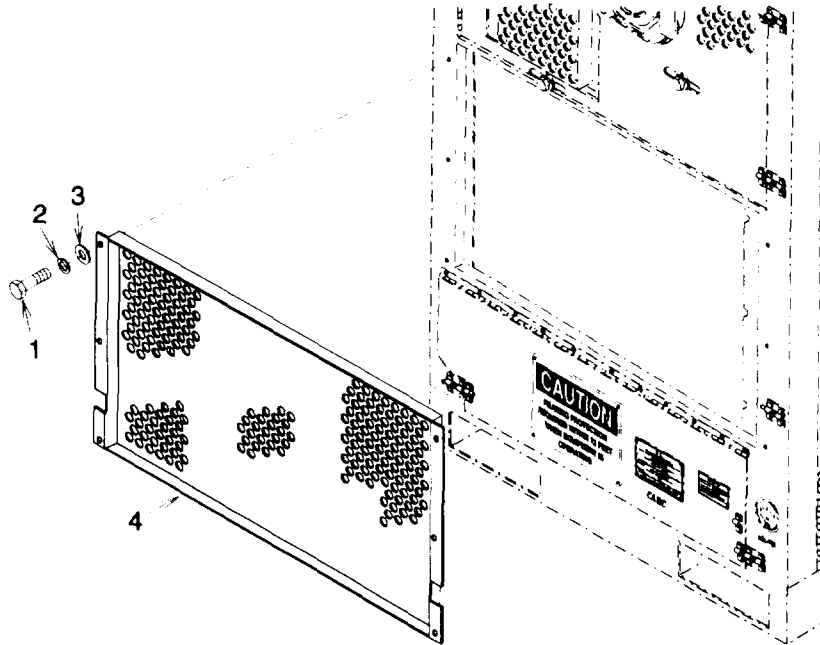

Figure 4-8. Front Coil Guard Panel

4-15. EVAPORATOR COVER PANEL REPLACEMENT.

This task covers:**a. Removal****b. Installation**

INITIAL SETUPEquipment Conditions:

Refrigeration unit shut down (para 2-7) and battery disconnected (para 4-35).

General Safety Instructions:**WARNING**

Exposed rotating parts are used in the refrigeration unit. Personal injury can result if battery is connected.

- a. Removal. Remove 34 bolts (1), flat washers (2), and evaporator cover panel (3).

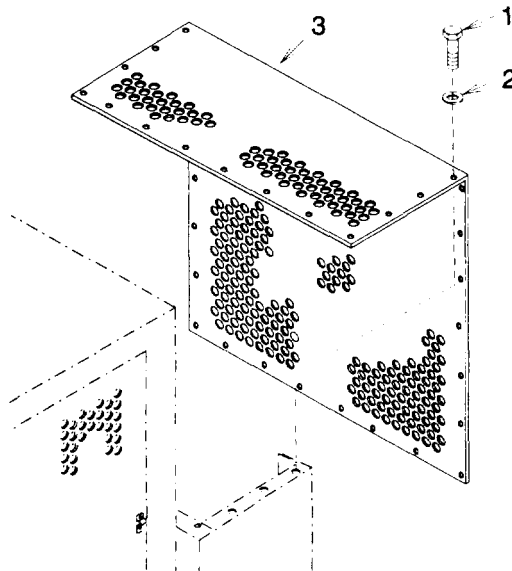
**Figure 4-9. Evaporator Cover Panel**

- b. Installation. Install evaporator cover panel (3), 34 flat washers (2), and bolts (1).

NOTE**FOLLOW-ON MAINTENANCE:**

Connect battery (para. 4-35) and put unit back into service.

4-16. ACCESS PANEL REPLACEMENT.

This task covers:

a. Removal

b. Installation

INITIAL SETUP

a. Removal.

(1) Remove eight screws (1), and access panel (2).

(2) If gasket material (3) is missing or damaged, notify direct support maintenance to repair or replace it as necessary.

b. Installation. Install access panel (2), and eight screws (1).

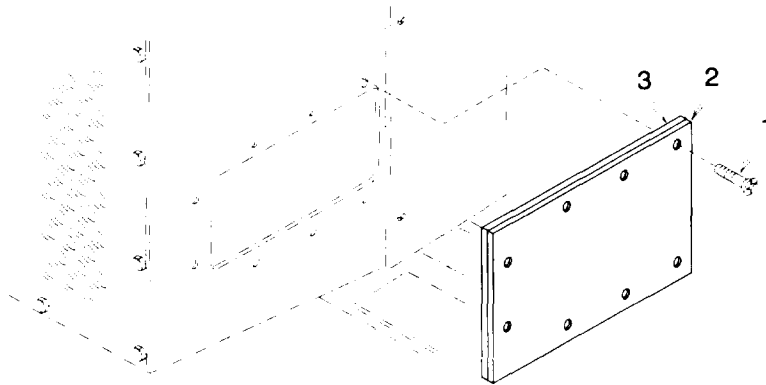

Figure 4-10. Access Panel

4-17. BARREL BOLT REPLACEMENT.**This task covers:****a. Removal****b. Installation****INITIAL SETUP**Materials/Parts:

Lock Washers (6) (Each Barrel Bolt Assembly
1, Appendix G

Equipment Conditions:

Refrigeration unit shut down (para. 2-7) and battery
disconnected (para. 4-35).

General Safety Instructions:**WARNING**

Exposed rotating parts are used in the
refrigeration unit. Personal injury can result if
battery is connected.

a. Removal.

- (1) Remove four bolts (1), lock washers (2), and barrel bolt (3). Discard lock washers.
- (2) Remove two bolts (4), lock washers (5), and barrel bolt clip (6). Discard lock washers.

b. Installation.

- (1) Install barrel bolt clip (6), two new lock washers (5), and bolts (4).
- (2) Install barrel bolt (3), four new lock washers (2), and bolts (1).

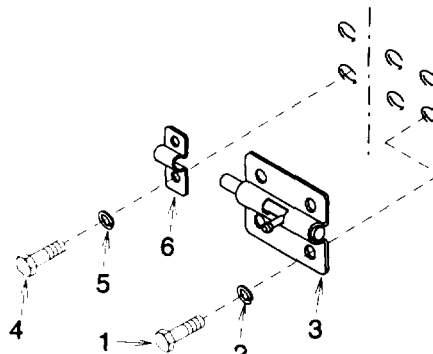
**Figure 4-11. Barrel Bolt****NOTE****FOLLOW-ON MAINTENANCE:**

Connect battery (para. 4-35) and put unit back into service.

4-18. UNIT MOUNTING BOLT ASSEMBLY REPLACEMENT.**This task covers:**

- | | | |
|------------------------|-----------------------|--------------------|
| a. Removal | b. Disassembly | c. Assembly |
| d. Installation | | |

INITIAL SETUPMaterials/Parts:

Self Locking Nut
3, Appendix C
Chain
Figure F-4 Appendix F
23, Appendix E

General Safety Instructions:**WARNING**

Exposed rotating parts are used in the refrigeration unit. Personal injury can result if battery is connected.

Equipment Conditions:

Refrigeration unit shut down (para. 2-7) and battery disconnected (para. 4-35).

NOTE

- **Chain, swivel and rivet are an assembly and do not have to be disassembled unless it is for replacement.**
- **The following procedures are typical for all four unit mounting bolt assemblies.**
 - a. Removal. Remove screw (1) and unit mounting bolt (2).
 - b. Disassembly.
 - (1) Remove self locking nut (3), swivel (4), flat washer (5), and bolt (2). Discard self locking nut.
 - (2) Drill through rivet (6) using drill bit slightly smaller than rivet diameter. Remove any remaining rivet material, swivel (4), and chain (7).

c. Assembly.

(1) Install chain (7) onto swivel (4) using new rivet (6).

(2) Install flat washer (5), swivel (4), and new self locking nut (3) onto bolt (2).

d. Installation. Install unit mounting bolt (2) and screw (1).

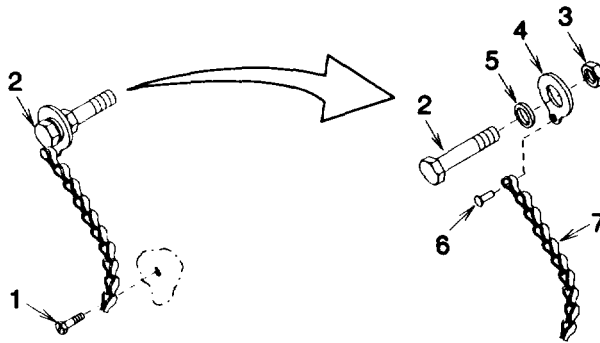

Figure 4-12. Unit Mounting Bolt Assembly

NOTE

FOLLOW-ON MAINTENANCE:
Connect battery (para. 4-35) and put unit back in service.

4-19. WIRES, CABLES, AND HARNESSES TESTING, REPAIR, AND REPLACEMENT .**This task covers:**

a. Testing
d. Installation

b. Repair

c. Removal

INITIAL SETUPTools:

Heat Gun

3, Section III, Appendix B

Materials/Parts:

Wire (As Required)

Insulation Sleeving (As Required)

Figure F-6, Appendix F

Lock Washers (2)

1, Appendix G

Solder, Appendix G

2, Appendix E

Flux

18, Appendix E

Marker Tag(s) (As Required)

4, Appendix E

Tie Down Strap(s) (As Required)

5, Appendix E

Silicone RTV

1, Appendix E

Equipment Conditions:

Refrigeration unit shut down (para 2-7) and battery disconnected (para 4-35).

Side doors open if needed.

Control box cover door raised and latched.

General Safety Instructions:**WARNING**

Exposed rotating parts are used in the refrigeration unit. Personal injury can result if battery is connected.

a. Testing.

- (1) Be sure battery has been disconnected then remove two bolts (1) and lock washers (2). Open control panel (3). Discard lock washers.
- (2) Tag and disconnect wire leads from components as necessary to isolate the wire or harness being tested.
- (3) Using multimeter set to measure continuity, check each end of the wire lead(s) (fig. 4-13 and table 4-4).
- (4) Replace any wire lead(s) that do not show continuity (table 4-4).
- (5) Connect wire lead(s) per tag and wiring diagram (fig. 1-4).

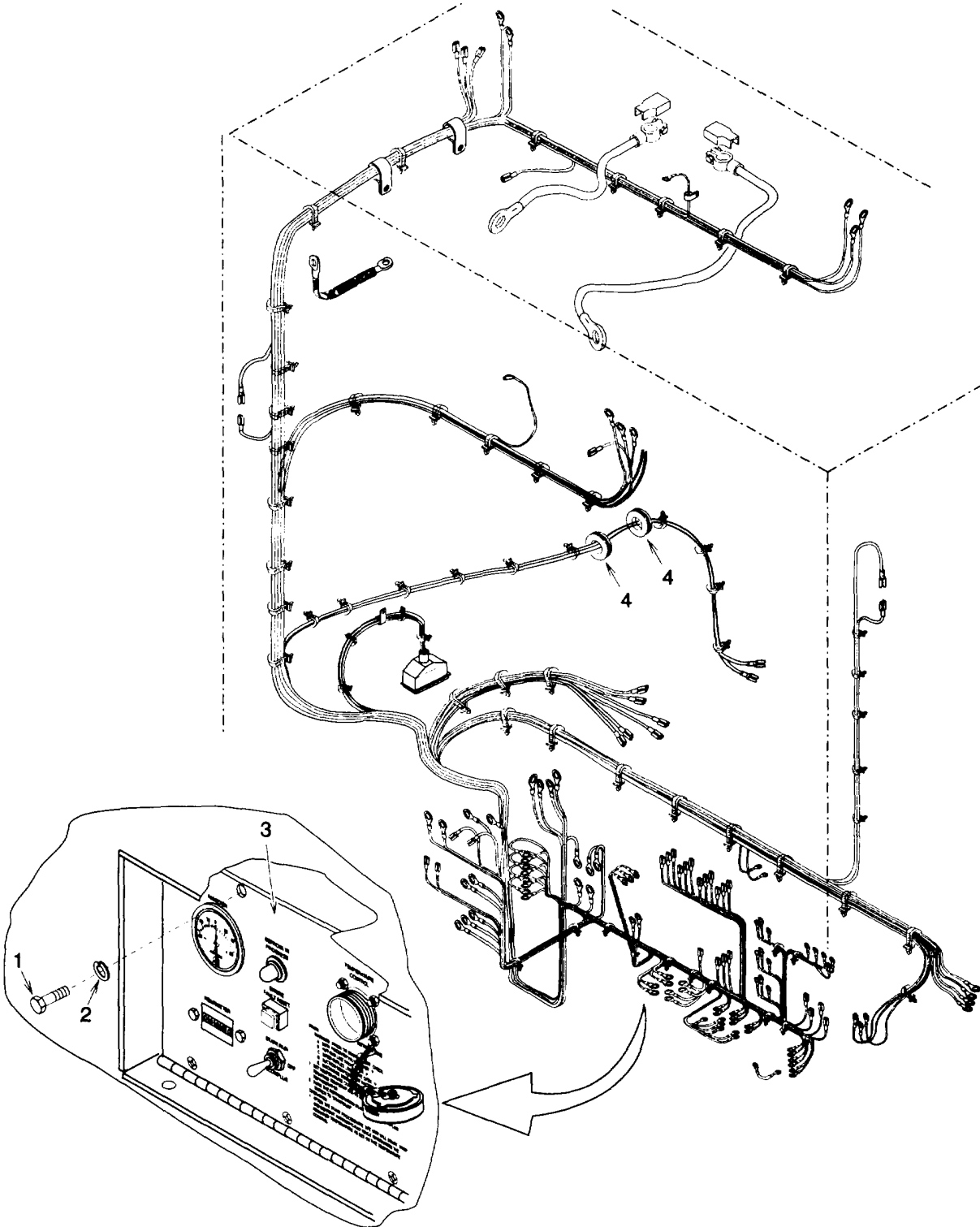

Figure 4-13. Wires Cables and Harnesses

4-19. WIRES, CABLES, AND HARNESSES TESTING, REPAIR, AND REPLACEMENT. - Continued

- b. Repair. Repairs can be performed to replace terminal ends or to splice wire when cut.

|WARNING

Solder and flux contain materials which are hazardous to health. Avoid breathing vapors or fumes from soldering operations. Perform operations only in well ventilated areas. Wash hands with soap and water after handling solder and flux. Wear thermal gloves and protective goggles or face shield to protect against burns.

- (1) Soldering Connections. Wire connections must be made mechanically sound before they are soldered; solder alone does not provide sufficient strength to prevent breakage. Joining surfaces of connections to be soldered must be clean and bright. Flux should be brushed onto the joint before soldering. Wires should always be heated to the point at which the solder will melt completely and flow into all parts of the joint. Excessive build up of solder "gobs" on the joint should be avoided or removed.
- (2) Insulating Joints. The preferred method of insulating electrical joints is by the use of heat-shrink tubing. To apply, cut a piece of heat-shrink tubing of suitable diameter to a length of 1 inch (2.5 cm) for covering joints at terminals or connectors, or to a length about 1/2 inch (1.3 cm) longer than the joint to be insulated. Slide the tubing over the wire before making the joint. After the joint is made, slide the tubing so that it covers the joint and shrink in place with moderate heat.
- (3) Splicing Wire. To repair broken or cut wires that are otherwise sound, the mating ends can be stripped and spliced. Solder and apply insulation as described above.
- (4) Crimping Terminals. To install a terminal on the end of a wire, strip 1/4-1/2 inch (0.6-1.3 cm) of insulation from the end of the wire and apply a one inch (2.4 cm) piece of heat shrink tubing (if the terminals are of the uninsulated type). Insert wire-end into the shank of the terminal. Crimp the shank and install heat-shrink tubing, if necessary.

NOTE

Preferred repair methods consist of replacing wires, terminals, connectors, etc., rather than splicing wires, bending ends to form terminals, and other make shift procedures, although the latter may be appropriate for emergency field repairs.

- (5) Wire Size and Length. Determine the proper size and length of the wire, or terminal, or connector to be used for replacement by referring to the wire list (table 4-4), and to the wiring diagram (fig. 1-4).

Table 4-4. Wire List

TERMINATION		TERMINATION			AWG WIRE SIZE	LENGTH	
FROM	TERMINAL TYPE	TO	TERMINAL TYPE	IN.		CM	
BT-POS	(D) 35095 (16004) (D) 80696 (16004)	K4-C	MS25036-127 (96906)	1 AWG	96	244	
BT-NEG	(D) 35095 (16004)	FR GND	MS25036-127 (96906)	1 AWG	18	46	
K4-C	MS25036-113 (96906)	F1-1	MS25036-156 (96906)	12 AWG	108	275	
F1-1	MS25036-153 (96906)	K1-7	13216E6191-2 (97403)	12 AWG	24	61	
F1-2	MS25036-153 (96906)	M1- (+)	MS25036-108 (96906)	12 AWG	24	61	
F1-2	MS25036-153 (96906)	F2-1	MS25036-153 (96906)	14 AWG	24	61	
F2-2	MS25036-153 (96906)	S1-2	MS25036-106 (96906)	14 AWG	24	61	
S10-NO	(D) 82898 (16004)	S2-1	MS25036-153 (96906)	14 AWG	120	305	
S2-1	MS25036-153 (96906)	TM1-9	MS25036-106 (96906)	14 AWG	24	61	
S2-2	MS25036-153 (96906)	VR- (/)	12712937-1 (19200)	16 AWG	156	397	
S2-2	MS25036-153 (96906)	TB1-1	MS25036-106 (96906)	14 AWG	24	61	
S2-1	MS25036-153 (96906)	K2-9	13216E6191-2 (97403)	14 AWG	24	61	
M1-(-)	MS25036-108 (96906)	VR- (+)	12712937-1 (19200)	12 AWG	108	275	
TB1-2	MS25036-106 (96906)	TM1-7	MS25036-106 (96906)	16 AWG	24	61	
M2-2	MS25036-153 (96906)	CB GND	MS25036-108 (96906)	16 AWG	24	61	
DS1-1	MS25036-106 (96906)	TM1-4	MS25036-106 (96906)	16 AWG	24	61	
DS1-2	MS25036-106 (96906)	CB GND	MS25036-108 (96906)	16 AWG	24	61	
CB1-LINE	13216E6191-2 (97403)	S2-2	MS25036-153 (96906)	16 AWG	24	61	
CB1-LOAD	13216E6191-2 (97403)	TB1-3	MS25036-106 (96906)	14 AWG	24	61	
K1-4	13216E6191-2 (97403)	K4- (+)	13216E6191-2 (97403)	12 AWG	120	305	
				SEE NOTE 1			
K1-A	13216E6191-2 (97403)	TB1-3	MS25036-106 (96906)	16 AWG	24	61	
K1-B	13216E6191-2 (97403)	S8-4	MS25036-106 (96906)	16 AWG	24	61	
TB1-2	MS25036-106 (96906)	S5-M	MS25036-153 (96906)	16 AWG	118	300	
K2-6	13216E6191-2 (97403)	S4-LINE	MS25036-153 (96906)	14 AWG	108	275	
TB1-2	MS25036-106 (96906)	TD2-X1	MS25036-106 (96906)	16 AWG	24	61	
K2-B	13216E6191-2 (97403)	CB GND	MS25036-108 (96906)	16 AWG	24	61	
K3-4	13216E6191-2 (97403)	TD1-NO	MS25036-106 (96906)	16 AWG	24	61	
K3-7	13216E6191-2 (97403)	TB1-3	MS25036-106 (96906)	16 AWG	24	61	
K3-A	13216E6191-2 (97403)	TM1-6	MS25036-106 (96906)	16 AWG	24	61	
S1-3	MS25036-106 (96906)	S9-C	(D) 82898 (16004)	14 AWG	120	305	

Table 4-4. Wire List - Continued

TERMINATION			TERMINATION			AWG WIRE SIZE	LENGTH	
FROM	TERMINAL TYPE		TO	TERMINAL TYPE			IN.	CM
TM1-A	MS25036-106	(96906)	S3-2	12712937-1	(19200)	16 AWG	96	244
S1-3	MS25036-106	(96906)	S3-1	12712937-1	(19200)	16 AWG	24	61
TM1-B	MS25036-106	(96906)	CB GND	MS25036-108	(96906)	16 AWG	24	61
CB GND	MS25036-108	(96906)	FR GND	MS25036-109	(96906)	16 AWG	88	224
CB GND	MS25036-108	(96906)	FR GND	MS25036-109	(96906)	16 AWG	88	224
CB GND	MS25036-108	(96906)	C1- (-)	12712937-1	(19200)	16 AWG	60	153
CB GND	MS25036-108	(96906)	L2-B	12712937-1	(19200)	16 AWG	108	275
CB GND	MS25036-108	(96906)	L1-B	12712937-1	(19200)	16 AWG	96	244
CB GND	MS25036-108	(96906)	S5-2	MS25036-153	(96906)	16 AWG	108	275
S4-M1	MS25036-153	(96906)	S5-L	MS25036-153	(96906)	16 AWG	36	92
K3-B	13216E6191-2	(97403)	TD2-C	MS25036-106	(96906)	16 AWG	24	61
TD1-XI	MS25036-106	(96906)	TD1-C	MS25036-106	(96906)	16 AWG	24	61
TD1-XI	MS25036-106	(96906)	TB1-3	MS25036-106	(96906)	16 AWG	24	61
TD1-X2	MS25036-106	(96906)	S8-4	MS25036-106	(96906)	16 AWG	24	61
TDI-NO	MS25036-106	(96906)	CB GND	13216E6191-2	(97403)	16 AWG	24	61
TB1-2	MS25036-106	(96906)	K2-A	13216E6191-2	(97403)	16 AWG	24	61
TD2-X2	MS25036-106	(96906)	CB GND	MS25036-108	(96906)	16 AWG	24	61
TD2-C	MS25036-106	(96906)	S7-C	MS27144-2	(96906)	16 AWG	120	305
TD2-NO	MS25036-106	(96906)	S6-C	12712937-1	(19200)	16 AWG	102	260
S8-1	MS25036-106	(96906)	T1-5	12712937-1	(19200)	16 AWG	24	61
S8-2	MS25036-106	(96906)	T1-8	12712937-1	(19200)	16 AWG	24	61
S8-3	MS25036-106	(96906)	CB GND	MS25036-108	(96906)	16 AWG	24	61
TB1-2	MS25036-106	(96906)	K3-9	13216E6191-2	(97403)	16 AWG	24	61
TB1-2	MS25036-106	(96906)	M2-1	MS25036-153	(96906)	16 AWG	24	61
S5-L	MS25036-153	(96906)	S5-12V	MS25036-153	(96906)	16 AWG	3	8
TB1-1	MS25036-106	(96906)	TM1-6	MS25036-106	(96906)	16 AWG	24	61

Table 4-4. Wire List - Continued

TERMINATION			TERMINATION			AWG WIRE SIZE	LENGTH	
FROM	TERMINAL TYPE		TO	TERMINAL TYPE			IN.	CM
K1-6	13216E6191-2	(97403)	S4-LINE	MS25036-153	(96906)	14 AWG	108	275
TB1-1	MS25036-106	(96906)	L1-A	12712937-1	(19200)	16 AWG	102	260
				12712936	(19200)			
TM1-1	MS25036-106	(96906)	C1- (+)	12712937-1	(19200)	16 AWG	64	163
				12712936	(19200)			
TM1-1	MS25036-106	(96906)	L2-A	12712937-1	(19200)	16 AWG	108	275
				12712936	(19200)			
S1-3	MS25036-106	(96906)	GAL-I	MS25036-108	(96906)	16 AWG	120	305
S9-NO	(D) 82898	(16004)	S10-C	(D) 82898	(16004)	14 AWG	204	519
K3-3	13216E6191-2	(97403)	L3-RED	12712937-1	(19200)	12 AWG	120	305
				12712936	(19200)			
GA1-S	MS25036-108	(96906)	SU1-S	MS25036-108	(96906)	16 AWG	62	158
SU1-GND	MS25036-108	(96906)	FR GND	MS25036-109	(96906)	16 AWG	18	46
GA1-GND	MS25036-108	(96906)	FR-GND	MS25036-109	(96906)	16 AWG	6	16
TB1-1	MS25036-106	(96906)	K1-9	13216E6191-2	(97403)	14 AWG	24	61
T1-1	13216E6191-2	(97403)	ALT-YEL	12712937-1	(19200)	16 AWG	156	397
T1-2	13216E6191-2	(97403)	ALT-YEL	12712937-1	(19200)	16 AWG	156	397
YEL (ALT)	1355AS376-1	(30003)	YEL	12712937-1	(REF)	14 AWG YEL	156	397
			(VR- -)			SEE NOTE 2		
YEL (ALT)	1355AS376-1	(30003)	YEL	12712937-1	(REF)	14 AWG YEL	156	397
			(VR- -)			SEE NOTE 2		
FR GND	MS25036-156	L3-BLK	12712937-1	(19200)	12 AWG	24	61	
				12712936	(19200)			
S1-1	MS25036-106	(96906)	K5-A	MS25036-108	(96906)	14 AWG	24	61
K4-C	MS25036-113	(96906)	K5-C	MS25036-113	(96906)	10 AWG	120	305
K5-NO	MS25036-113	(96906)	GLPG	MS25036-112	(96906)	10 AWG	120	305
CB GND	MS25036-108	(96906)	K5-GND	MS25036-108	(96906)	14 AWG	24	61
K4-NO	13216E6192-3	(97403)	L3-WHT	12712937-1	(19200)	12 AWG	36	92
				12712936	(19200)			

NOTE

- 1 - Use sleeving for marking wires.
- 2 - No wire markings used on color coded wires.

4-19. WIRES, CABLES, AND HARNESSES TESTING, REPAIR, AND REPLACEMENT. - Continuedc. Removal.

- (1) Tag and disconnect wire lead(s) from component.
- (2) Cut tie down straps and loosen clamp(s) as necessary to remove wire(s).
- (3) Remove any silicone RTV remaining in evaporator frame grommets (4).

d. Installation.

- (1) Carefully route wire lead(s) through clamp(s) and grommet(s) as necessary.
- (2) Connect wire lead(s) to component using tags and wiring diagram (fig. 1-4). Remove tags.
- (3) Install tie down straps as necessary and tighten any clamp(s) that were loosened for removal.
- (4) Apply silicone RTV into evaporator frame grommets (4) to seal evaporator enclosure.
- (5) Close control panel (3). Install two new lock washers (2) and bolts (1).

NOTE**FOLLOW-ON MAINTENANCE:**

Close side doors if open.

Unlatch and close control box cover.

Connect battery (para. 4-35) and put unit back into service.

4-20. CONTROL BOX ASSEMBLY REPLACEMENT.**This task covers:****a. Removal****b. Installation****INITIAL SETUP**Materials/Parts:

Lock Washers (2) (Control Panel)

1, Appendix G

Lock Washers (2) (Bracket)

1, Appendix G

Lock Washer (Clamps)

1, Appendix G

Self Locking Nut

4, Appendix G

Tie Down Strap(s) (As Required)

5, Appendix E

Silicone RTV

1, Appendix E

Marker Tags (As Required)

4, Appendix E

Equipment Conditions:

Refrigeration unit shut down (para. 2-7) and battery disconnected (para. 4-35).

Control box cover door raised and latched.

Left side door open.

General Safety Instructions:**WARNING**

Exposed rotating parts are used in the refrigeration unit. Personal injury can result if battery is connected.

a. Removal.

- (1) Be sure battery has been disconnected then remove two bolts (1) and lock washers (2). Open control panel (3). Discard lock washers.
- (2) Remove two bolts (4), lock washers (5), flat washers (6), and sensing bulb bracket (7). Discard lock washers.
- (3) Remove self locking nut (8), lock washer (9), and bolt (10). Discard lock washer and self locking nut.
- (4) Remove clamp (11) but not clamp (12).
- (5) Cut tie down straps (13) and remove grommets (14) as necessary to remove sensing bulb (15). Carefully pull sensing bulb through access sleeve (16) in heat shield frame.
- (6) Remove any silicone RTV remaining in grommets (14).
- (7) Tag and disconnect wire leads from components as necessary. Cut tie down straps as necessary and pull leads from control box assembly.
- (8) Remove lock nut (17) and strain relief cable bushing (18).
- (9) Remove six screws (19) and control box assembly (20).

4-20. CONTROL BOX ASSEMBLY REPLACEMENT. - Continued

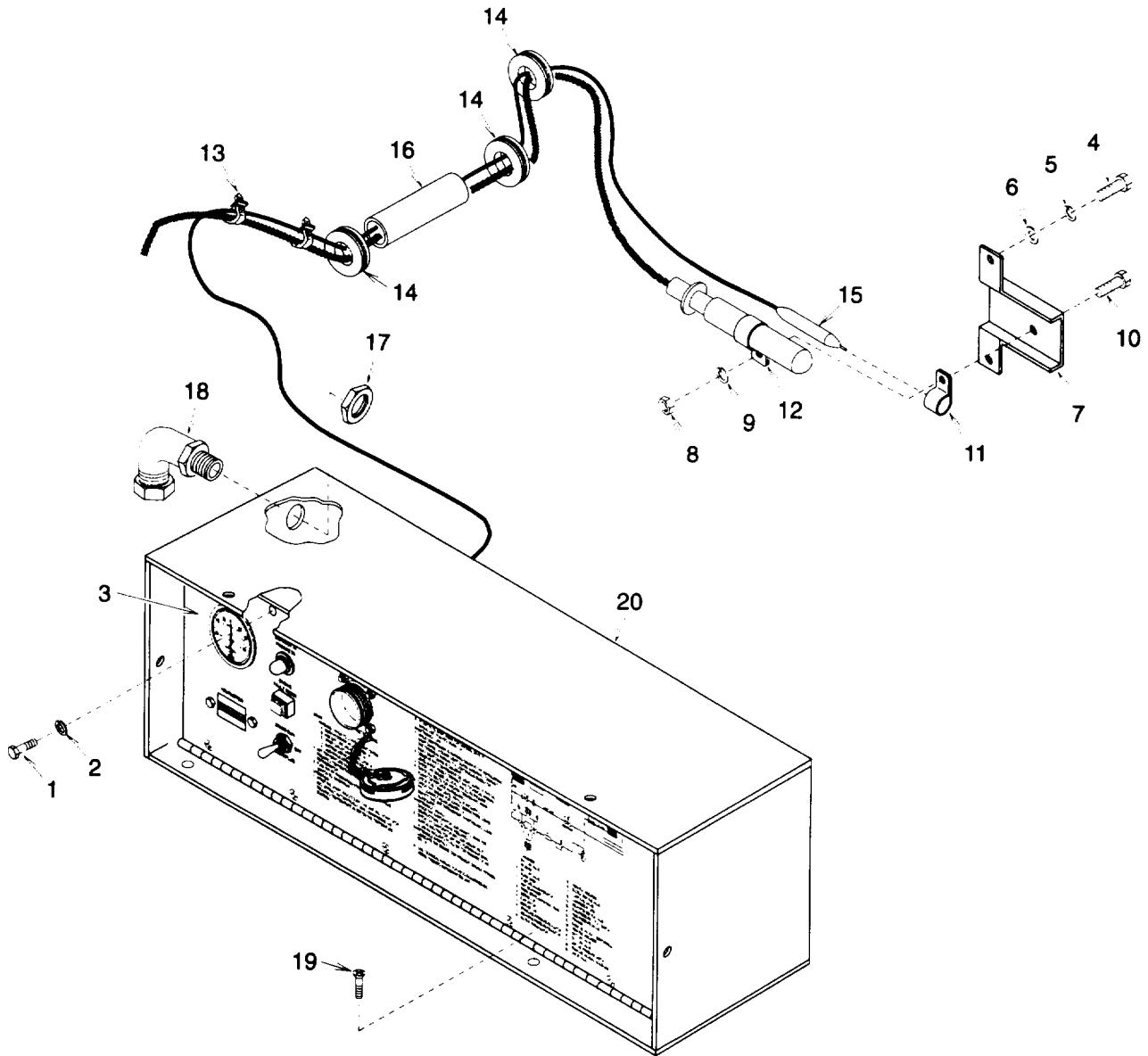

Figure 4-14. Control Box Assembly

b. Installation.

- (1) Install control box assembly (20) and secure with six screws (19).
- (2) Push wires leads through strain relief cable bushing (8).
- (3) Install strain relief cable bushing (18) through control box (20) and secure with lock nut (17).
- (4) Using tags and wiring diagram (fig 1-4), connect all wire leads to appropriate components. Remove tags.
- (5) Carefully push sensing bulb (15) through grommets (14), and access sleeve (16). Install tie down straps as necessary.
- (6) Install grommets (14) and tie down straps (13) as necessary.
- (7) Slip clamp (11) over sensing bulb (15).
- (8) Install clamps (11) and (12), bolt (10), new lock washer(9) and new self locking nut (8).
- (9) Install sensing bulb bracket (7), two flat washers (6), new lock washers (5), and bolts (4).
- (10) Close control panel (3) and install two new lock washers (2) and bolts (1).
- (11) Apply silicone RTV into grommets (14) to seal evaporator enclosure.

NOTE**FOLLOW-ON MAINTENANCE:**

**Unlatch and close control box cover door.
Connect battery (para 4-35) and put unit back into service.**

4-21. CIRCUIT BREAKER CB1 TESTING AND REPLACEMENT.

This task covers:

a. Testing

b. Removal

c. Installation

INITIAL SETUP

Materials/Parts:

- Lock Washers (2)
1, Appendix G
- Marker Tags (2)
4, Appendix E

Equipment Conditions:

- Refrigeration unit shut down (para 2-7) and battery disconnected (para 4-35).
- Control box cover door raised and latched.

a. Testing. (See Figure 1-4.)

- (1) Be sure battery has been disconnected then remove two bolts (1) and lock washers (2). Open control panel (3). Discard lock washers.
- (2) Tag and disconnect wire leads (4).

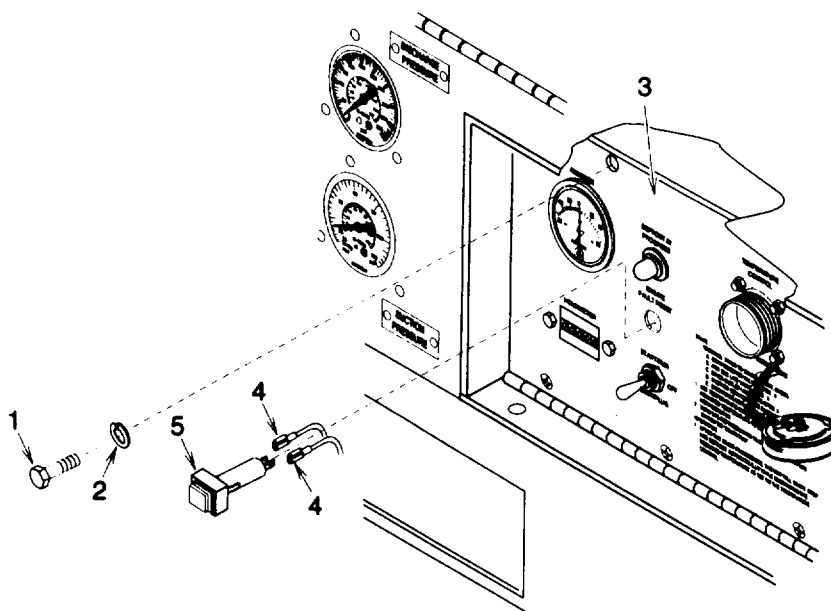

Figure 4-15. Circuit Breaker

NOTE

The circuit breaker can be manually operated by pushing the button. When on, the button is in. When off, the button is out exposing a white band.

- (3) Using multimeter set to measure continuity, check circuit breaker (5) continuity between terminals 1 to 2, with circuit breaker in both the on (button in, no white band showing) and off (button out, white band showing) position. Continuity should be indicated only when circuit breaker is in the on position. If continuity was indicated in the off position or if no continuity was indicated in the on position, replace circuit breaker.
- (4) If no failure was indicated, install wire leads (4) per tags and wiring diagram (fig. 14). Remove tags.
- (5) Close control panel (3) and install two new lock washers (2) and bolts (1).

b. Removal.

- (1) Be sure battery has been disconnected then remove two bolts (1) and lock washers(2). Open control panel (3). Discard lock washers.
- (2) Tag and disconnect wire lead terminals (4).
- (3) Pinch the side tabs on circuit breaker (5) and remove from the front of the control panel (3).

c. Installation.

- (1) Install circuit breaker (5) through the front of the control panel (3).
- (2) Using tags and wiring diagram (fig. 1-4), install wire lead terminals (4). Remove tags.
- (3) Close control panel (3) and install two new lock washers (2) and bolts (1).
- (4) Be sure circuit breaker (5) button is pushed in, and white band is not showing.

NOTE

**FOLLOW-ON MAINTENANCE:
Unlatch and close control box cover door.
Connect battery (para 4-35) and put unit back into service.**

4-22. LAMP ASSEMBLY DS1 TESTING AND REPLACEMENT.**This task covers:****a. Testing****b. Removal****c. Installation****INITIAL SETUP**Materials/Parts:

Lock Washers (2)
 1, Appendix G
 Marker Tags (2)
 4, Appendix E

Equipment Conditions:

Refrigeration unit shut down (para 2-7) and battery disconnected (para 4-35).
 Control box cover door raised and latched.

a. Testing. (See Figure 1-4.)

- (1) Be sure battery has been disconnected and remove indicator cap (1).
- (2) Remove lamp (2).

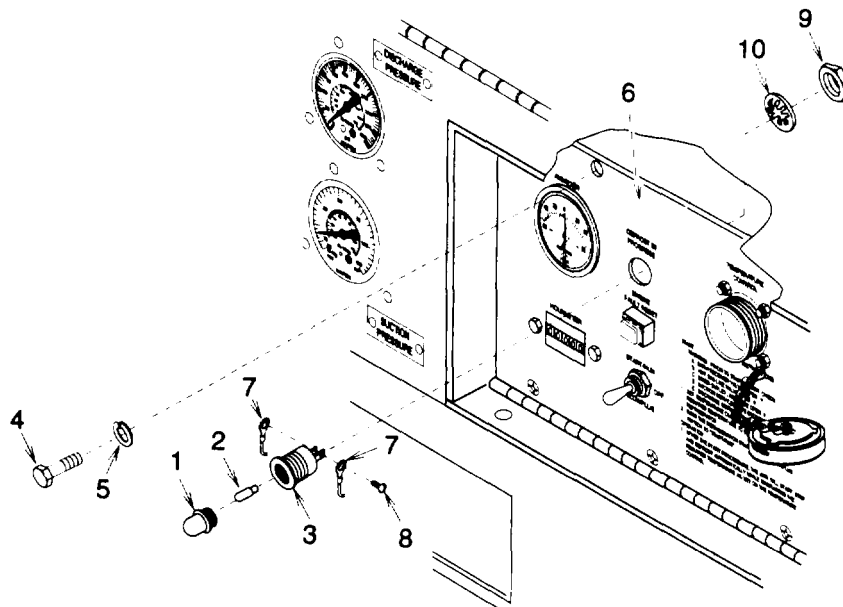
**Figure 4-16. Lamp Assembly**

- (3) Using multimeter set to measure continuity, check lamp (2) continuity between terminals. Continuity should be indicated. If no continuity was indicated, replace lamp.
- (4) If indicator base (3) is damaged, replace it.
- (5) If no failure was indicated, install lamp (2) and indicator cap (1).

b. Removal.

- (1) Be sure battery has been disconnected and remove indicator cap (1) and lamp (2).
- (2) Remove two bolts (4) and lock washers (5). Open control panel (6). Discard lock washers.

NOTE

Terminal and base mounting hardware is supplied with indicator base.

- (3) Tag wire lead terminals (7) and remove two screws (8) and wire lead terminals.
- (4) Remove nut (9), lock washer (10), and indicator base (3).

c. Installation.

- (1) Install indicator base (3), lock washer (10), and nut (9).
- (2) Using tags and wiring diagram (fig. 1-4), install wire lead terminals (7) and two screws (8). Remove tags.
- (3) Close control panel (6). Install two new lock washers (5) and bolts (4).
- (4) Install lamp (2) and indicator cap (1).

NOTE

**FOLLOW-ON MAINTENANCE:
Unlatch and close control box cover door.
Connect battery (para 4-35) and put unit back into service.**

4-23. FUSES F1 AND F2 TESTING AND REPLACEMENT.

This task covers:
a. Testing**b. Removal****c. Installation**

INITIAL SETUPMaterials/Parts:

Lock Washers (2)
 1, Appendix G
 Marker Tags (4)
 4, Appendix E

Equipment Conditions:

Refrigeration unit shut down (para 2-7) and battery disconnected (para 4-35).
 Control box cover door raised and latched.

a. Testing. (See Figure 1-4.)

- (1) Be sure battery has been disconnected then remove two bolts (1) and lock washers (2). Open control panel (3). Discard lock washers.

NOTE

One each 15 amp and 30 amp fuse is used.

- (2) Note location and remove two fuses (4) and (5).

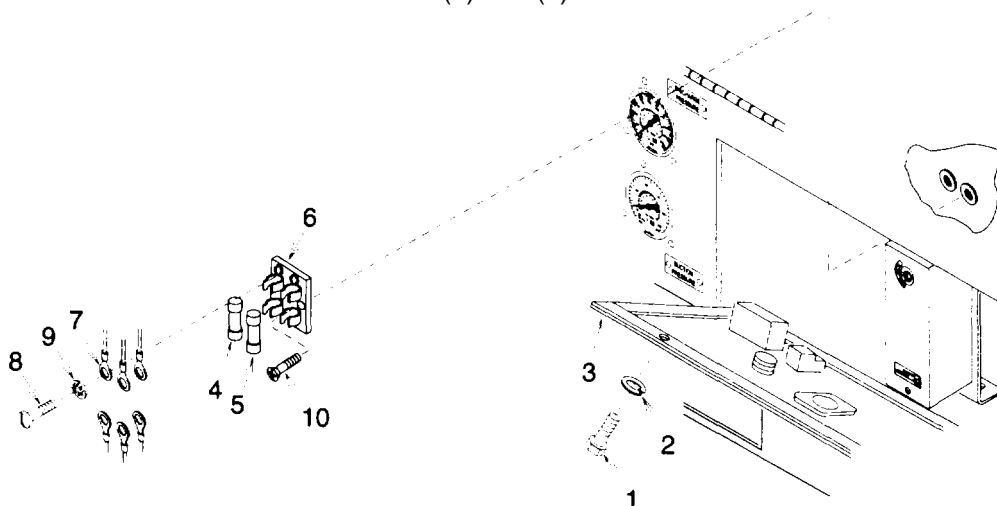

Figure 4-17. Fuses

- (3) Using multimeter set to measure continuity, check continuity between each fuse (4) and (5) ends. Continuity should be indicated. If no continuity was indicated, replace fuse(s).
- (4) If fuse block (6) is damaged, replace it.
- (5) If no failure was indicated, install fuse (4) and (5) in position noted during removal, close control panel (3) and install two new lock washers (2) and bolts (1).

b. Removal.

- (1) Be sure battery has been disconnected then remove two bolts (1) and lock washers (2). Open control panel (3). Discard lock washers.

NOTE

One each 15 amp and 30 amp fuse is used.

- (2) Note location and remove two fuses (4) and (5).

NOTE

Terminal hardware is supplied with fuse block.

- (3) Tag wire lead terminals (7) and remove four screws (8), lock washers (9), and wire lead terminals.
- (4) Remove two screws (10) and fuse block (6).

c. Installation.

- (1) Install fuse block (6) and two screws (10).
- (2) Using tags and wiring diagram (fig. 1-4), install wire lead terminals (7), four lock washers (9), and screws (8). Remove tags.
- (3) Install two fuses (4) and (5) in location noted during removal.
- (4) Close control panel (3). Install two new lock washers (2) and bolts (1).

NOTE

**FOLLOW-ON MAINTENANCE:
Unlatch and close control box cover door.
Connect battery (para 4-35) and put unit back into service.**

4-24. CONTROL RELAYS K1, K2 AND K3 TESTING AND REPLACEMENT.**This task covers:****a. Testing****b. Removal****c. Installation****INITIAL SETUP**Materials/Parts:

Lock Washers (2)
 1, Appendix G
 Lock Washer (2 Each Relay)
 5, Appendix G
 Marker tags (6) (K1, K3)
 4, Appendix E
 Marker tags (4) (K2)
 4, Appendix E

Equipment Conditions:

Refrigeration unit shut down (para 2-7) and battery disconnected (para 4-35).
 Control box cover door raised and latched.
 Defrost timer removed (para 4-29).

a. Testing. (See Figure 1-4.)

- (1) Be sure battery has been disconnected then remove two bolts (1) and lock washers (2). Open control panel (3). Discard lock washers.
- (2) Tag and disconnect wire leads (4).
- (3) Using multimeter set to measure continuity, check each control relay (5) coil continuity between terminals A to B. Continuity should be indicated. If no continuity was indicated, replace control relay.
- (4) Using multimeter set to measure continuity, check each control relay (5) contact continuity between terminals 7 to 4 (K3 and K4) and 9 to 6 (K4). No continuity should be indicated. If continuity was indicated, replace control relay (5).
- (5) If no failure was indicated, using tags and wiring diagram (fig. 1-4), install wire leads (4). Remove tags.
- (6) Close control panel (3) and install two new lock washers (2) and bolts (1).

b. Removal.

- (1) Be sure battery has been disconnected and remove two bolts (1) and lock washers (2). Open control panel (3). Discard lock washers.

NOTE

The following procedures apply to all three control relays K1, K2 and K3. Quantities given are for each relay.

- (2) Tag and disconnect wire leads (4).
- (3) Remove bolt (6), lock washer (7), flat washer (8), and control relay (5). Discard lock washer.

c. Installation.**NOTE**

The following procedures apply to all three control relays K1, K2 and K3. Quantities given are for each relay.

- (1) Install control relay (5), flat washer (8), new lock washer (7), and bolt (6).
- (2) If wire lead (4) terminals were damaged, repair per paragraph 4-19.
- (3) Using tags and wiring diagram (fig. 1-4), install wire leads (4). Remove tags.
- (4) Close control panel (3). Install two new lock washers (2) and bolts (1).

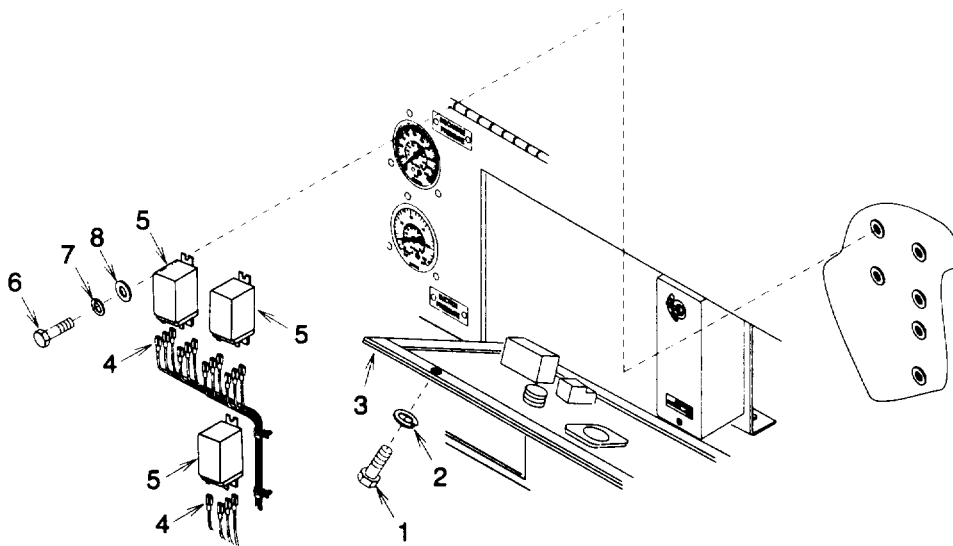

Figure 4-18. Control Relays

NOTE

FOLLOW-ON MAINTENANCE:
 Install defrost timer (para 4-29).
 Unlatch and close control box cover door.
 Connect battery (para 4-35) and put unit back into service.

4-25. TIME DELAY RELAYS TD1 AND TD2 TESTING AND REPLACEMENT.

This task covers:

a. Testing

b. Removal

c. Installation.

INITIAL SETUP

Materials/Parts:

- Marker tags (8)
4, Appendix E
- Adhesive Tape
Figure F-39, Appendix F
- Lock Washers (2)
1, Appendix G
- Lock Washers (4)
5, Appendix G

Equipment Conditions:

- Refrigeration unit shut down (para 2-7) and battery disconnected (para 4-35).
- Control box cover door raised and latched.

a. Testing. (See Figure 1-4.)

- (1) Be sure battery has been disconnected then remove two bolts (1) and lock washers (2). Open control panel (3). Discard lock washers.

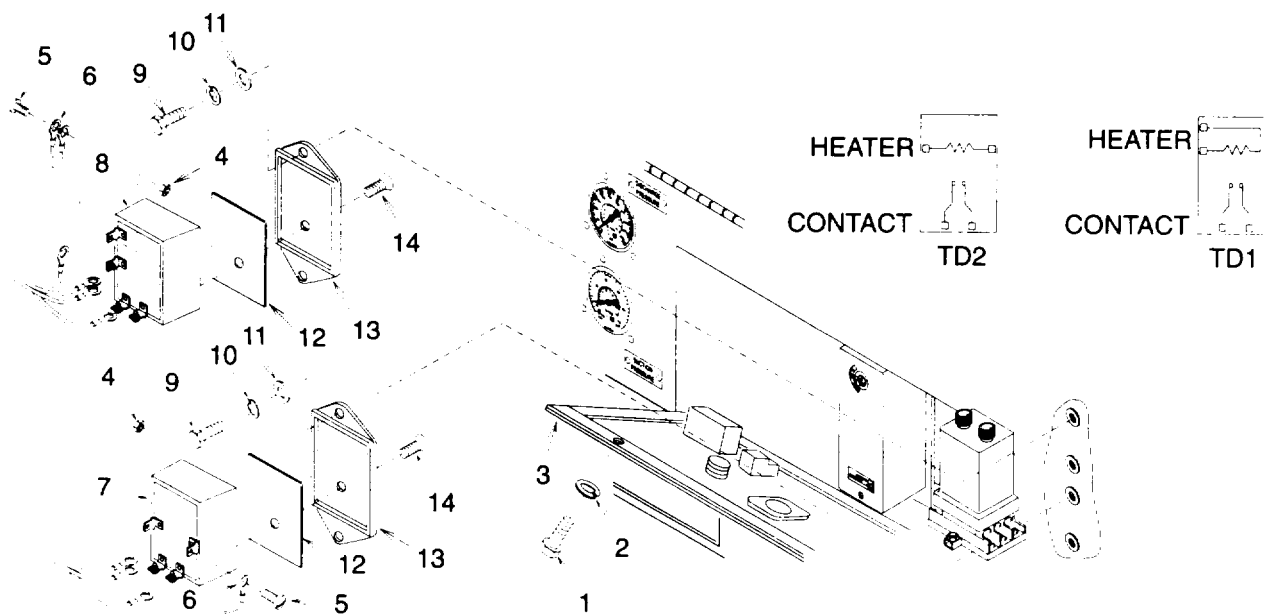

Figure 4-19. Time Delay Relay

NOTE

- **The following procedures apply to both TD1 and TD2. Quantities given are for each relay.**

- **Terminal hardware is supplied with time delay relay.**

- (2) Tag wire leads and remove nut (4), screw (5) and wire lead (6) from time delay relay (7) and (8).
- (3) Using multimeter set to measure continuity, check continuity between heater terminals. Continuity should be indicated. If no continuity was indicated, replace time delay relay (7) or (8).
- (4) Using multimeter set to measure continuity, check continuity between contact terminals. Continuity should not be indicated. If continuity was indicated, replace time delay relay (7) or (8).
- (5) If no failure was indicated, install wire leads (6) using tags and wiring diagram (fig. 1-4). Remove tags.
- (6) Close control panel (3) and install two new lock washers (2) and bolts (1).

b. Removal.

- (1) Be sure battery has been disconnected and remove two bolts (1) and lock washers (2). Open control panel (3). Discard lock washers.

NOTE

- **The following procedures apply to both TD1 and TD2. Quantities given are for each relay.**

- **Terminal hardware is supplied with time delay relay.**

- (2) Tag wire leads (6) and remove nut (4), screw (5) and wire leads (6) from time delay relay (7) or (8).
- (3) Remove two bolts (9), lock washers (10), flat washers (11), and time delay relay (7) or (8). Discard lock washers.

4-25. TIME DELAY RELAYS TD1 AND TD2 TESTING AND REPLACEMENT. - Continuedc. Installation.**NOTE**

- **The following procedures apply to both TD1 and TD2. Quantities given are for each relay.**
 - **Terminal hardware is supplied with time delay relay.**
- (1) Secure time delay relay (7) or (8) to mounting plate (13) using adhesive tape. Install screw (14) through mounting plate into time delay relay.
 - (2) Install time delay relay (7) or (8), using two flat washers (11), new lock washers (10), and bolts (9).
 - (3) If wire lead (6) terminals were damaged, repair per paragraph 4-19.
 - (4) Using tags and wiring diagram (fig. 1-4), install wire leads (6), nuts (4) and screws (5). Remove tags.
 - (5) Close control panel (3). Install two new lock washers (2) and bolts (1).

NOTE

FOLLOW-ON MAINTENANCE:
Unlatch and close control box cover door.
Connect battery (para 4-35) and put unit back into service.

4-26. HOURMETER M2 TESTING AND REPLACEMENT.

This task covers:
a. Testing**b. Removal****c. Installation.****INITIAL SETUP**Materials/Parts:

Lock Washers (2)
 1, Appendix G
 Self Locking Nuts (2)
 6, Appendix G
 Marker tags (2)
 4, Appendix E

Equipment Conditions:

Refrigeration unit shut down (para 2-7) and battery disconnected (para 4-35).
 Control box cover door raised and latched.

a. Testing. (See Figure 1-4.)

- (1) Be sure battery has been disconnected then remove two bolts (1) and lock washers (2). Open control panel (3). Discard lock washers.

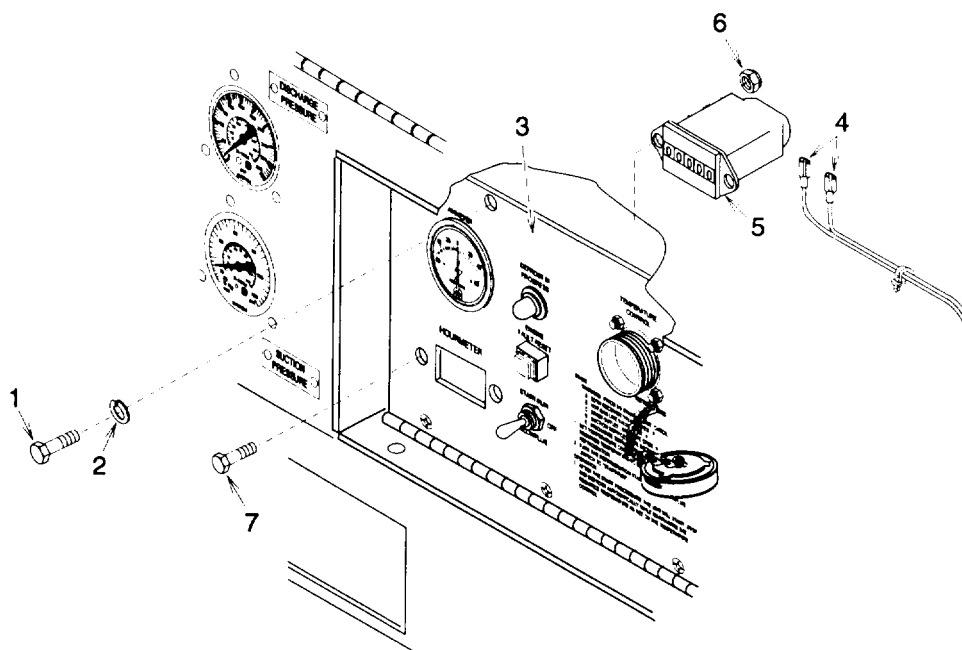
**Figure 4-20. Hourmeter**

- (2) Tag and disconnect wire leads (4).
- (3) Using multimeter set to measure continuity, check hourmeter (5) continuity between terminals. Continuity should be indicated. If no continuity was indicated, replace hourmeter.

4-26. HOURMETER M2 TESTING AND REPLACEMENT. - Continued

- (4) If no failure was indicated, install wire leads (4) using tags and wiring diagram (fig. 1-4). Remove tags.
- (5) Close control panel (3) and install two new lock washers (2) and bolts (1).

b. Removal.

- (1) Be sure battery has been disconnected then remove two bolts (1) and lock washers (2). Open control panel (3). Discard lock washers.

NOTE

Terminal hardware is supplied with hourmeter.

- (2) Tag wire leads (4) and remove.
- (3) Remove two self locking nuts (6), bolts (7), and hourmeter (5). Discard self locking nuts.

c. Installation.

- (1) Install hourmeter (5), two bolts (7), and new self locking nuts (6).
- (2) Using tags and wiring diagram (fig. 1-4), install wire leads (4) and remove tags.
- (3) Close control panel (3). Install two new lock washers (2) and bolts (1).

NOTE

**FOLLOW-ON MAINTENANCE:
Unlatch and close control box cover door.
Connect battery (para 4-35) and put unit back into service.**

4-27. AMMETER M1 TESTING AND REPLACEMENT.

This task covers:

a. Testing

b. Removal

c. Installation.

INITIAL SETUP

Materials/Parts:

- Lock Washers (2)
1, Appendix G
- Marker tags (2)
4, Appendix E

Equipment Conditions:

- Refrigeration unit shut down (para 2-7) and battery disconnected (para 4-35).
- Control box cover door raised and latched.

a. Testing. (See Figure 1-4.)

- (1) Be sure battery has been disconnected then remove two bolts (1) and lock washers (2). Open control panel (3). Discard lock washers.

NOTE

Terminal hardware is supplied with ammeter.

- (2) Tag wire leads (4) and remove two nuts (5), lock washers (6) and wire leads.

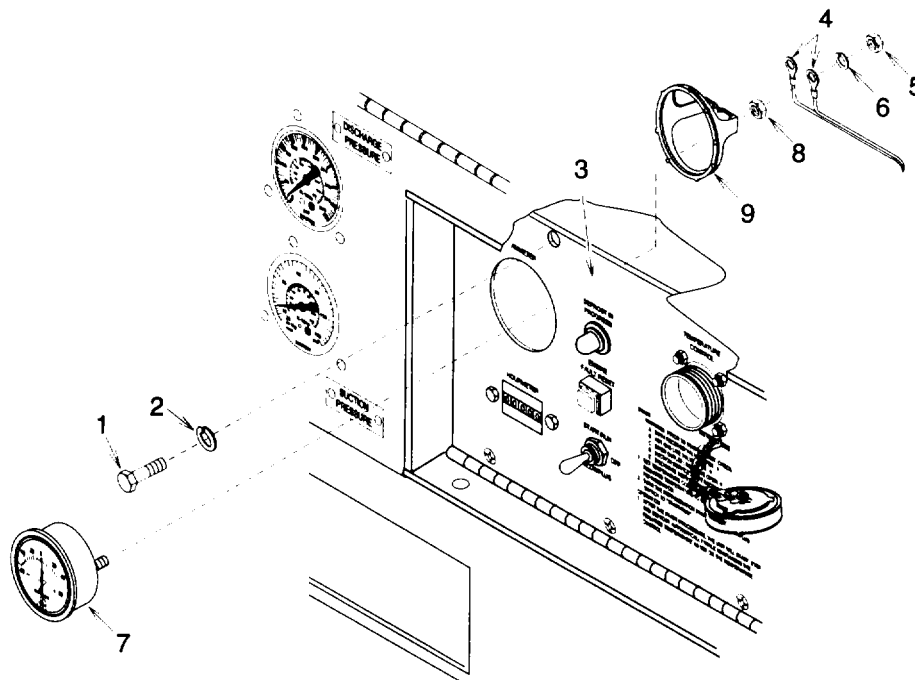

Figure 4-21. Ammeter

4-27. AMMETER M1 TESTING AND REPLACEMENT. - Continued

- (3) Using multimeter set to measure continuity, check ammeter (7) continuity between terminals. Continuity should be indicated. If no continuity was indicated, replace ammeter.
- (4) If no failure was indicated, install wire leads (4) using tags and wiring diagram (fig. 1-4), two lock washers (6), and nuts (5). Remove tags.
- (5) Close control panel (3) and install two new lock washers (2) and bolts (1).

b. Removal.

- (1) Be sure battery has been disconnected then remove two bolts (1) and lock washers (2). Open control panel (3). Discard lock washers.

NOTE

Terminal hardware is supplied with ammeter.

- (2) Tag wire leads (4) and remove two nuts (5), lock washers (6) and wire leads.
- (3) Remove two self locking nuts (8), plastic bracket (9), and ammeter (7).

c. Installation.**NOTE**

Terminal hardware is supplied with ammeter.

- (1) Install ammeter (7), plastic bracket (9), and two self locking nuts (8).
- (2) Using tags and wiring diagram (fig. 1-4), install wire leads (4), two lock washers (6), and nuts (5). Remove tags.
- 3) Close control panel (3). Install two new lock washers (2) and bolts (1).

NOTE

**FOLLOW-ON MAINTENANCE:
Unlatch and close control box cover door.
Connect battery (para 4-35) and put unit back into service.**

4-28. TOGGLE SWITCH S1 TESTING AND REPLACEMENT.

This task covers:
a. Testing**b. Removal****c. Installation.****INITIAL SETUP**Materials/Parts:

Lock Washers (2)
 1, Appendix G
 Marker tags (2)
 4, Appendix E

Equipment Conditions:

Refrigeration unit shut down (para 2-7) and battery disconnected (para 4-35).
 Control box cover door raised and latched.

a. Testing. (See Figure 1-4.)

- (1) Be sure battery has been disconnected then remove two bolts (1) and lock washers (2). Open control panel (3). Discard lock washers.

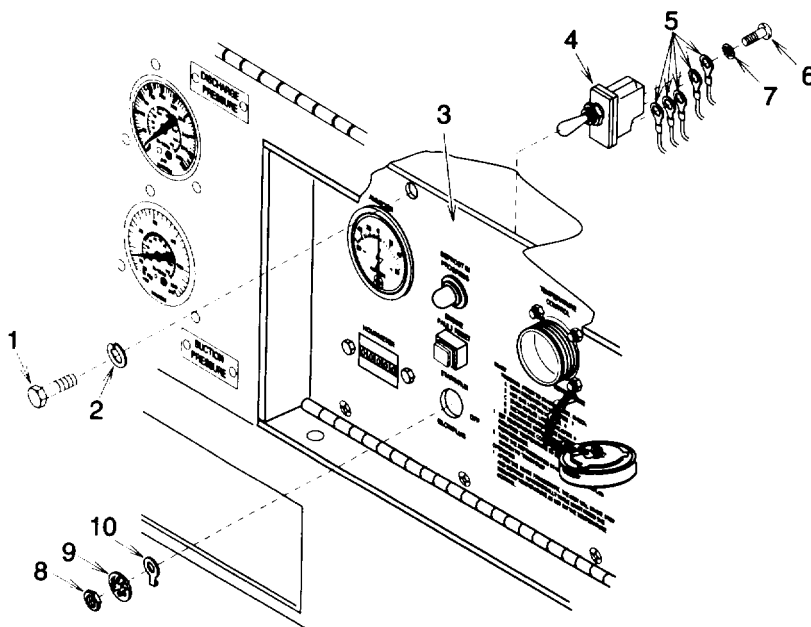
**Figure 4-22. Toggle Switch**

- (2) Using multimeter set to measure continuity, check toggle switch (4) continuity between terminals 2 to 3 with toggle switch in both START/RUN and OFF position. Continuity should be indicated only when toggle switch is in the START/RUN position. If continuity was indicated in the OFF position or if no continuity was indicated in the START/RUN position, replace toggle switch.

4-28. TOGGLE SWITCH S1 TESTING AND REPLACEMENT. Continued

- (3) Using multimeter set to measure continuity, check toggle switch (4) continuity between terminals 2 to 1 with toggle switch in both GLOWPLUG and OFF position. Continuity should be indicated only when toggle switch is in the GLOWPLUG position. If continuity was indicated in the OFF position or if no continuity was indicated in the GLOWPLUG position, replace toggle switch.
- (4) If no failure was indicated, close control panel (3) and install two new lock washers (2) and bolts (1).

b. Removal.

- (1) Be sure battery has been disconnected then remove two bolts (1) and lock washers (2). Open control panel (3). Discard lock washers.

NOTE

Terminal and mounting hardware is supplied with toggle switch.

- (2) Tag wire leads (5) and remove two screws (6), lock washers (7), and wire leads.
- (3) Remove nut (8), lock washer (9), retainer (10), and toggle switch (4).

c. Installation.**NOTE**

Terminal and mounting hardware is supplied with toggle switch.

- (1) Install toggle switch (4), retainer (10), lock washer (9), and nut (8).
- (2) Using tags and wiring diagram (fig. 1-4), install wire leads (5), two lock washers (7), and screws (6). Remove tags.
- (3) Close control panel (3). Install two new lock washers (2) and bolts (1).

NOTE

**FOLLOW-ON MAINTENANCE:
Unlatch and close control box cover door.
Connect battery (para 4-35) and put unit back into service.**

4-29. DEFROST TIMER TM1 TESTING AND REPLACEMENT.

This task covers:

a. Testing

b. Removal

c. Installation.

INITIAL SETUPMaterials/Parts:

Lock Washers (2)
 1, Appendix G
 Self Locking Nut (2)
 6, Appendix G
 Tie Down Strap
 7, Appendix E
 Marker tags (7)
 4, Appendix E

Equipment Conditions:

Refrigeration unit shut down (para 2-7) and battery disconnected (para 4-35).
 Control box cover door raised and latched.

General Safety Instructions:**WARNING**

Exposed rotating parts are used in the refrigeration unit. Personal injury can result if battery is connected.

a. Testing. (See Figure 1-4.)

- (1) Be sure battery has been disconnected then remove two bolts (1) and lock washers (2). Open control panel (3). Discard lock washers.
- (2) Remove and discard tie down strap (4).
- (3) Pull defrost timer (5) from relay mounting socket (6).
- (4) Using multimeter set to measure continuity, check defrost timer (5) continuity between terminals 1 to 7. Continuity should be indicated. If no continuity was indicated, replace defrost timer.
- (5) Using multimeter set to measure continuity, check defrost timer (5) continuity between terminals 4 to 7 and 6 to 9. No continuity should be indicated. If continuity was indicated, replace defrost timer.
- (6) If relay mounting socket (6) is damaged, replace it.
- (7) If no failure was indicated, push defrost timer (5) into relay mount socket (6) and install new tie down strap (4).
- (8) Close control panel (3) and install two new lock washers (2) and bolts (1).

b. Removal.

- (1) Be sure battery has been disconnected and remove two bolts (1) and lock washers (2). Open control panel (3). Discard lock washers.
- (2) Cut and discard tie down strap (4).
- (3) Pull defrost timer (5) from relay mounting socket (6).

4-29. DEFROST TIMER TM1 TESTING AND REPLACEMENT. - Continued

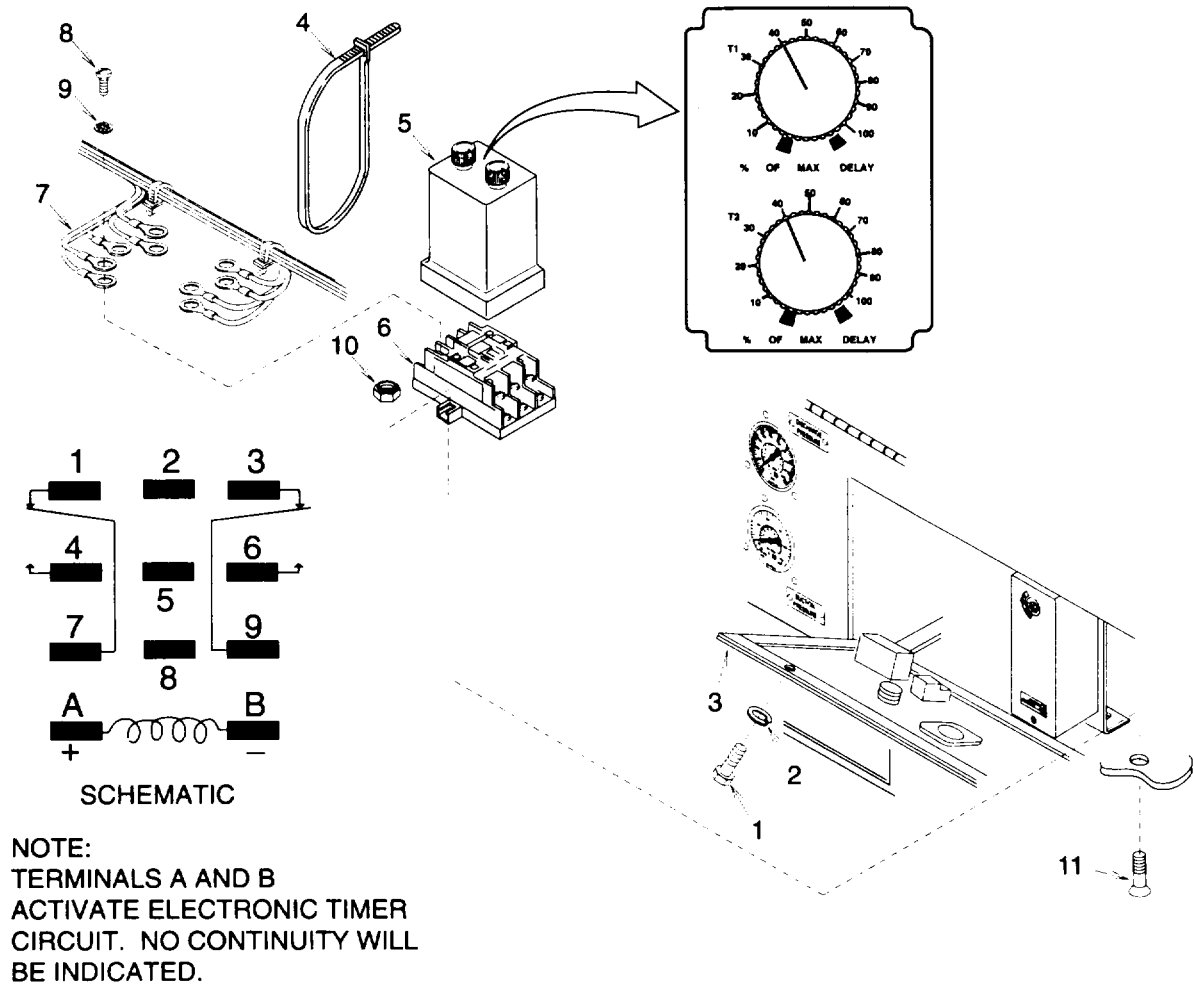

Figure 4-23. Defrost Timer

NOTE

Terminal hardware is supplied with relay mounting socket.

- (4) Tag wire leads (7) and remove seven screws (8), lock washers (9), and wire leads.
- (5) Remove two self locking nuts (10), screws (11), and relay mounting socket (6). Discard self locking nuts.

c. Installation.

- (1) Install relay mounting socket (6), two screws (11), and new self locking nuts (10).

NOTE

Terminal hardware is supplied with relay mounting socket.

- (2) Using tags and wiring diagram (fig. 1-4), install wire leads (7), seven lock washes (9), and screws (8). Remove tags.
- (3) Push defrost timer (5) into relay mounting socket (6) and install new tie down strap (4).
- (4) Adjust controls (para 4-8) as necessary.
- (5) Close control panel (3) and install two new lock washers (2) and bolts (1).

NOTE

FOLLOW-ON MAINTENANCE:

**Unlatch and close control box cover door.
Connect battery (para 4-35) and put unit back into service.**

4-30. REMOTE BULB THERMOSTAT S2 TESTING AND REPLACEMENT.**This task covers:****a. Testing****b. Removal****c. Installation****INITIAL SETUP**Materials/ Parts:

Lock Washers (2) (Control Panel)

1, Appendix G

Lock Washers (2) (Bulb Bracket)

1, Appendix G

Self Locking Nut

4, Appendix G

Self Locking Nuts (4) (Thermostat)

6, Appendix G

Self Locking Nuts (2) (Thermostat Bracket)

6, Appendix G

Self Locking Nuts (4) (Dummy Stowage Connector)

6, Appendix G

Tie Down Straps

5, Appendix E

Marker tags (2)

4, Appendix E

Silicone RTV

1, Appendix E

Equipment Conditions:

Refrigeration unit shut down (para 2-7) and battery disconnected (para 4-35).

Control box cover door raised and latched.

Left side condenser door open.

Evaporator cover panel removed (para 4-15).

General Safety Instructions:**WARNING****Exposed rotating parts are used in the refrigeration unit. Personal injury can result if battery is connected.****a. Testing. (See Figure 1-4.)**

- (1) Be sure battery has been disconnected then remove two bolts (1) and lock washers (2). Open control panel (3). Discard lock washers.
- (2) Remove screw (4) and cover (5).
- (3) Remove two bolts (6), lock washers (7), flat washers (8) and sensing bulb bracket (9). Discard lock washers.
- (4) Remove self locking nut (10), bolt (11), and sensing bulb bracket (9). Discard self locking nut.
- (5) Remove clamp (12).
- (6) Immerse sensing bulb (13) into a temperature controlled bath at 32° F (0° C). A bath at this temperature can be made by putting the sensing bulb into a container of ice and covering with water. Ice must remain packed around sensing bulb at all times during test.
- (7) Using multimeter set to measure continuity, check remote bulb thermostat (14) continuity between terminals 1 and 3 with thermostat setting at 24° F and at 40° F (-4° C and 4° C). Continuity should be indicated only when the setting is at 24° F (-4° C). If continuity was indicated at 40° F (4° C) setting, replace thermostat.

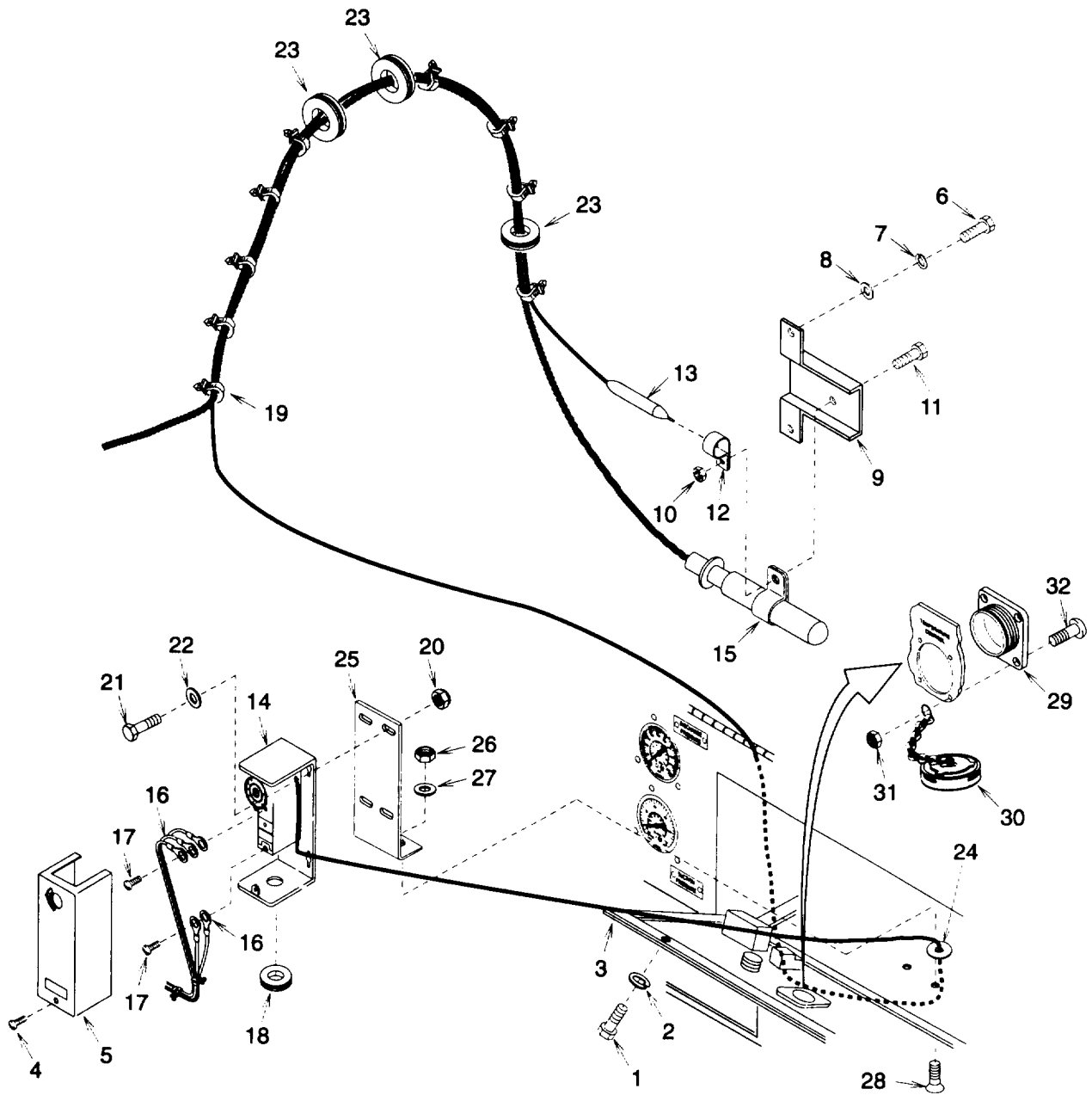

Figure 4-24. Remote Bulb Thermostat (Temperature Control)

4-30. REMOTE BULB THERMOSTAT S2 TESTING AND REPLACEMENT .-Continued

- (8) If no failure was indicated, slip clamp (12) over sensing bulb (13).
- (9) Install clamps (12) and (15), bolt (11), and new self locking nut (10).
- (10) Install sensing bulb bracket (9), two flat washers (8), new lock washers (7) and bolts (6).
- (11) Install cover (5) and screw (4).
- (12) Close control panel (3) and install two new lock washers (2) and bolts (1).

b. Removal.

- (1) Be sure battery has been disconnected then remove two bolts (1) and lock washers (2). Open control panel (3). Discard lock washers.
- (2) Remove screw (4) and cover (5).
- (3) Remove two bolts (6), lock washers (7), flat washers (8) and sensing bulb bracket (9). Discard lock washers.
- (4) Remove self locking nut (10), bolt (11), and sensing bulb bracket (9). Discard self locking nut.
- (5) Remove clamp (12).
- (6) Tag wire leads (16) then remove two screws (17) and wire leads.
- (7) Pull wire leads (16) from remote bulb thermostat (14) and remove grommet (18).
- (8) Cut tie down straps (19).
- (9) Remove four self locking nuts (20), bolts (21), and flat washers (22). Discard self locking nuts.
- (10) Remove remote bulb thermostat (14), grommets (23) and (24), and sensing bulb (13).
- (11) If temperature control switch bracket (25) is damaged, remove two self locking nuts (26), flat washers (27), screws (28), and bracket. Discard self locking nuts.
- (12) If dummy stowage connector (29) or cover (30) are damaged, remove four self locking nuts (31), bolts (32), cover, and dummy stowage connector. Discard self locking nuts.
- (13) Remove any silicone RTV remaining in evaporator frame grommets (23).

c. Installation.

- (1) If removed, install dummy stowage connector (29), four bolts (32), cover (30), and four new self locking nuts (31).
- (2) If removed, install temperature control bracket (25), two screws (28), flat washers (27), and new self locking nuts (26).
- (3) Install remote bulb thermostat (14), sensing bulb (13), and grommets (23) and (24).
- (4) Install remote bulb thermostat (14), four flat washers (22), bolts (21), and new self locking nuts (20).
- (5) Install tie down straps (19) as necessary.
- (6) Install grommet (18) and push wire leads (16) into remote bulb thermostat (14).
- (7) Using tags and wiring diagram (fig. 1-4), install wire leads (16) and two screws (17). Remove tags.
- (8) Slip clamp (12) over sensing bulb (13).
- (9) Install clamps (12) and (15), sensing bulb bracket (9), bolt (11), and new self locking nut (10).
- (10) Install sensing bulb bracket (9), two flat washers (8), new lock washers (7), and bolts (6).
- (11) Install cover (5) and screw (4).
- (12) Close control panel (3) and install two new lock washers (2) and bolts (1).
- (13) Apply silicone RTV into evaporator frame grommets (23) to seal evaporator enclosure.

NOTE**FOLLOW-ON MAINTENANCE:**

Unlatch and close control box cover door.

Close left side door.

Install evaporator cover panel (para 4-15).

Connect battery (para 4-35) and put unit back into service.

4-31. ENGINE SPEED SWITCH S8 REPLACEMENT.

This task covers:
a. Removal**b. Installation****INITIAL SETUP****Materials/Parts:**

Lock Washers (2)
 1, Appendix G
 Lock Washers (4)
 5, Appendix G
 Marker tags (4)
 4, Appendix E

Equipment Conditions:

Refrigeration unit shut down (para 2-7) and battery disconnected (para 4-35).
 Control box cover door raised and latched.

a. Removal.

- (1) Be sure battery has been disconnected then remove two bolts (1) and lock washers (2). Open control panel (3). Discard lock washers.

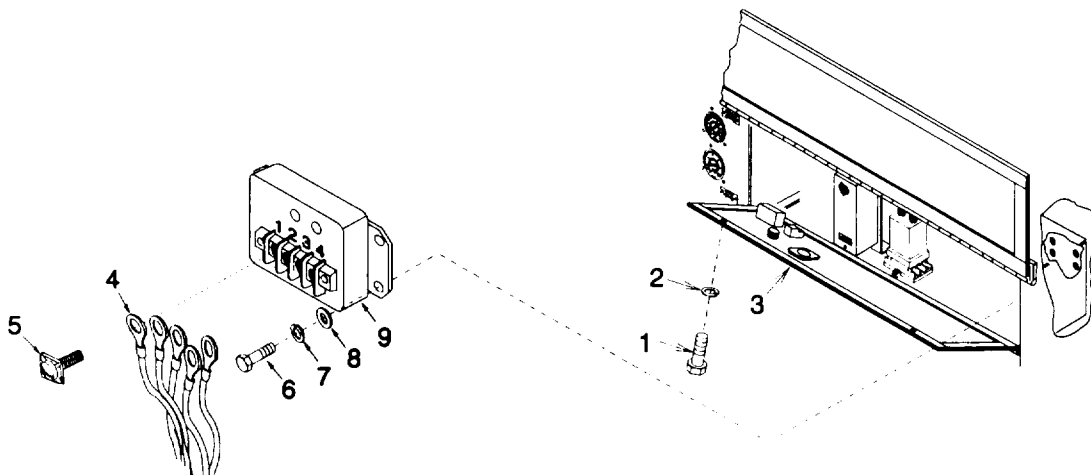
**Figure 4-25. Engine Speed Switch****NOTE**

Terminal hardware is supplied with engine speed switch.

- (2) Tag wire leads (4). Remove four screws (5) and wire leads.
- (3) Remove four bolts (6), lock washers (7), flat washers (8) and engine speed switch (9). Discard lock washers.

b. Installation.

CAUTION

The engine speed switch must be factory set at 83 hertz for the engine to operate properly. Equipment damage can result if not set to this frequency.

- (1) Be sure engine speed switch (9) has been factory set at 83 hertz. Install engine speed switch, four new lock washers (7), flat washers (8), and bolts (6).
- (2) Using tags and wiring diagram (fig. 1-4), install wire leads (4), and four screws (5). Remove tags.
- (3) Close control panel (3). Install two new lockwashers (2) and bolts (1).

NOTE

**FOLLOW-ON MAINTENANCE:
Unlatch and close control box cover door.
Connect battery (para 4-35) and put unit back into service.**

4-32. CONTROL TRANSFORMER T1 TESTING AND REPLACEMENT.

This task covers:
a. Testing**b. Removal****c. Installation**

INITIAL SETUP**Materials/Parts:**

Lock Washers (2)
 1, Appendix G
 Lock Washers (2)
 5, Appendix G
 Marker tags (4)
 4, Appendix E

Equipment Conditions:

Refrigeration unit shut down (para 2-7) and battery disconnected (para 4-35).
 Control box cover door raised and latched.

a. Testing. (See Figure 1-4.)

- (1) Be sure battery has been disconnected then remove two bolts (1) and lock washers (2). Open control panel (3). Discard lock washers.

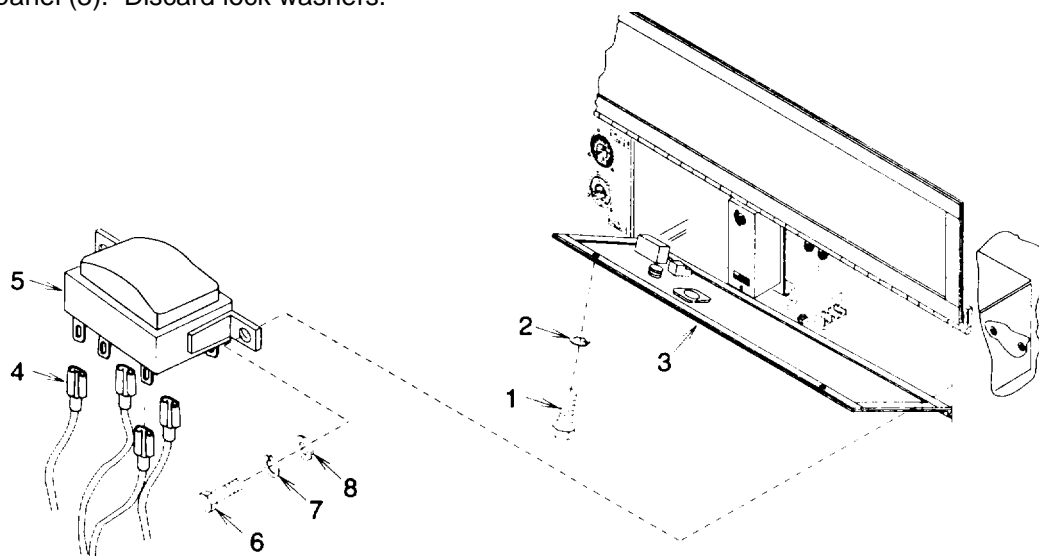
**Figure 4-26. Control Transformer T1**

- (2) Tag and disconnect wire leads (4).
- (3) Using multimeter set to measure continuity, check control transformer (5) continuity between terminals 1 to 2 and 5 to 8. Continuity should be indicated. If no continuity was indicated, replace control transformer.
- (4) Check continuity between either terminals 1 to 5, or 1 to 8. No continuity should be indicated. If continuity was indicated, replace control transformer.

- (5) Check continuity between each terminal and the case. No continuity should be indicated. If continuity was indicated, replace control transformer.
- (6) If no failure was indicated, install wire leads (4) using tags and wiring diagram (fig. 1-4). Remove tags.
- (7) Close control panel (3) and install two new lock washers (2) and bolts (1).

b. Removal.

- (1) Be sure battery has been disconnected then remove two bolts (1) and lock washers (2). Open control panel (3). Discard lock washers.
- (2) Tag wire leads (4) and remove.
- (3) Remove two bolts (6), lock washers (7), flat washers (8), and control transformer (5). Discard lock washers.

c. Installation.

- (1) Install control transformer (5), two bolts (6), flat washers (8) and new lock washers (7).
- (2) Using tags and wiring diagram (fig. 1-4), install wire leads (4) and remove tags.
- (3) Close control panel (3). Install two new lock washers (2) and bolts (1).

NOTE

FOLLOW-ON MAINTENANCE:
Unlatch and close control box cover door.
Connect battery (para 4-35) and put unit back into service.

4-33. THERMOMETER TESTING AND REPLACEMENT.**This task covers:****a. Testing****b. Removal****c. Installation****INITIAL SETUP****Materials/Parts:**

Lock Washers (2)

1, Appendix G

Self Locking Nut

4, Appendix G

Self Locking Nuts (3)

6, Appendix G

Tie Down Straps

5, Appendix E

Silicone RTV

1, Appendix E

Equipment Conditions:

Refrigeration unit shut down (para 2-7) and battery disconnected (para 4-35).

Control box cover door raised and latched.

Left side door open.

Evaporator cover panel removed (para 4-15).

General Safety Instructions:**WARNING****Exposed rotating parts are used in the refrigeration unit. Personal injury can result if battery is connected.****a. Testing.**

- (1) Be sure battery has been disconnected then remove two bolts (1), lock washers (2), flat washers (3), and sensing bulb bracket (4). Discard lock washers.
- (2) Remove self locking nut (5), bolt (6), and sensing bulb bracket (4). Discard self locking nut.
- (3) Remove clamp (7).
- (4) Immerse sensing bulb (8) into a temperature controlled bath at 32° F (0° C). A bath at this temperature can be made by putting the sensing bulb into a container of ice and covering with water. Ice must remain packed around sensing bulb at all times during test.
- (5) Check temperature indicated on thermometer (9). Temperature indicated should be between 24° F and 40° F (-4° C and 4° C). If temperature indicated is above or below this range, replace thermometer.
- (6) If no failure was indicated, slip clamp (7) over sensing bulb (8).
- (7) Install clamps (7) and (10), bolt (6), sensing bulb bracket (4), and new self locking nut (5).
- (8) Install sensing bulb bracket (4), two bolts (1), new lock washers (2) and flat washers (3).

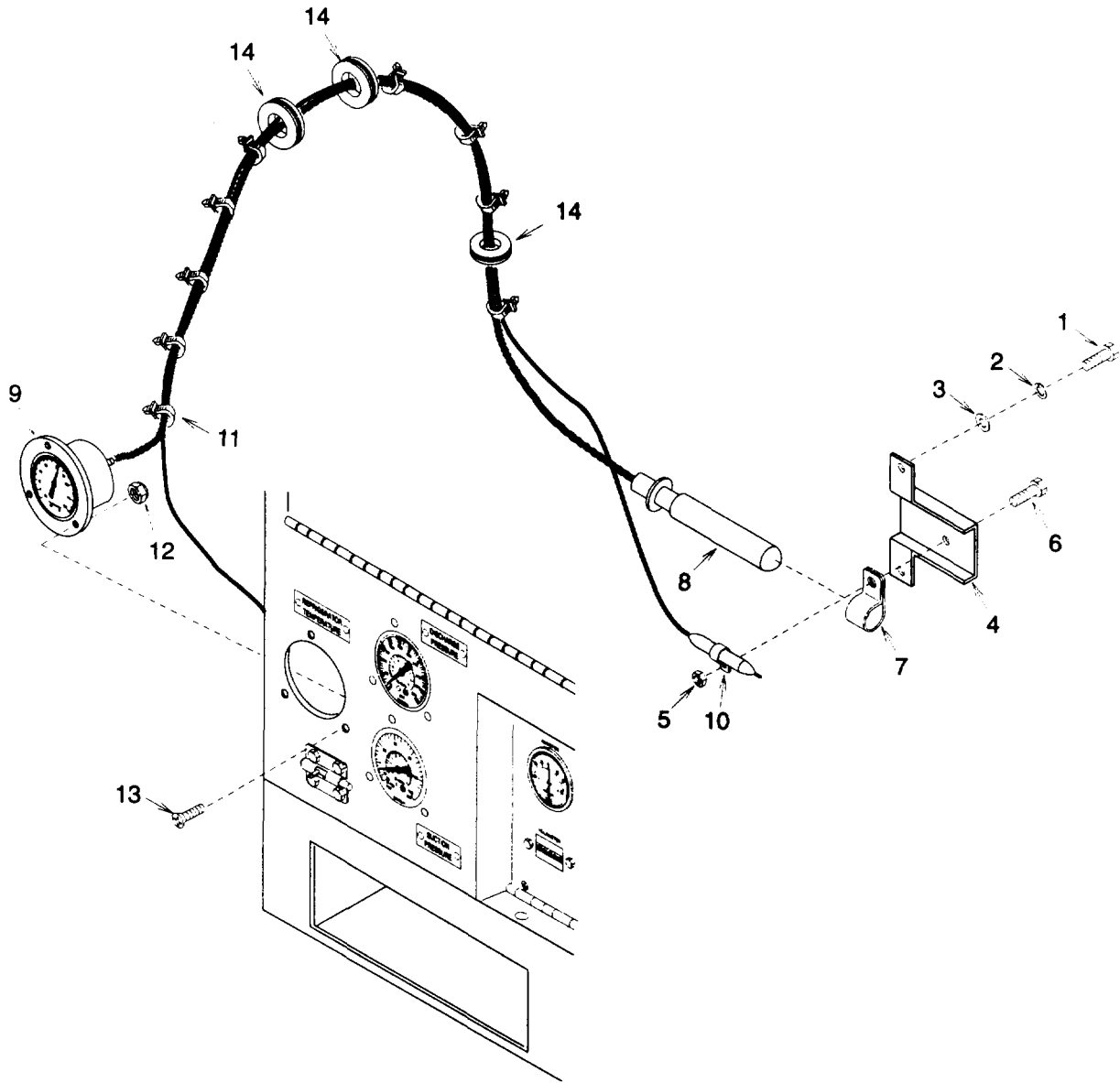

Figure 4-27. Refrigeration Temperature Gage (Thermometer)

4-33. THERMOMETER TESTING AND REPLACEMENT .-Continued**b. Removal.**

- (1) Be sure battery has been disconnected then remove two bolts (1), lock washers (2), flat washers (3), and sensing bulb bracket (4). Discard lock washers.
- (2) Remove self locking nut (5), bolt (6) and sensing bulb bracket (4). Discard self locking nut.
- (3) Remove clamp (7) from sensing bulb (8).
- (4) Cut tie down straps (11).
- (5) Remove three self locking nuts (12) and bolts (13). Discard self locking nuts.
- (6) Remove thermometer (9) and any grommets (14) necessary to remove sensing bulb (8).
- (7) Remove any silicone RTV remaining in evaporator frame grommets (14).

c. Installation.

- (1) Install thermometer (9) routing sensing bulb (8) through grommets (14). Install any grommets removed.
- (2) Secure thermometer (9) using three bolts (13) and new self locking nuts (12).
- (3) Install tie down straps (11) as necessary.
- (4) Slip clamp (7) over sensing bulb (8).
- (5) Install clamps (7) and (10), sensing bulb (4), bolt (6), and new self locking nut (5).
- (6) Install sensing bulb bracket (4), two flat washers (3), new lock washers (2) and bolts (1).
- (7) Apply silicone RTV into evaporator frame grommets (14) to seal evaporator enclosure.
- (8) Apply silicone RTV around openings in back of thermometer (9) case to seal thermometer.

NOTE**FOLLOW-ON MAINTENANCE:**

Unlatch and close control box cover door.

Close left side door.

Install evaporator cover panel (para 4-15).

Connect battery (para 4-35) and put unit back into service.

4-34. CONTINUOUS DUTY SOLENOID K5 TESTING AND REPLACEMENT .**This task covers:****a. Testing****b. Removal****c. Installation****INITIAL SETUP****Materials/Parts:**

Lock Washers (2)
 1, Appendix G
 Self Locking Nuts (2)
 4, Appendix G
 Marker tags (4)
 4, Appendix E

Equipment Conditions:

Refrigeration unit shut down (para 2-7) and battery disconnected (para 4-35).
 Control box cover door raised and latched.

a. Testing. (See Figure 1-4.)

- (1) Be sure battery has been disconnected then remove two bolts (1) and lock washers (2). Open control panel (3). Discard lock washers.

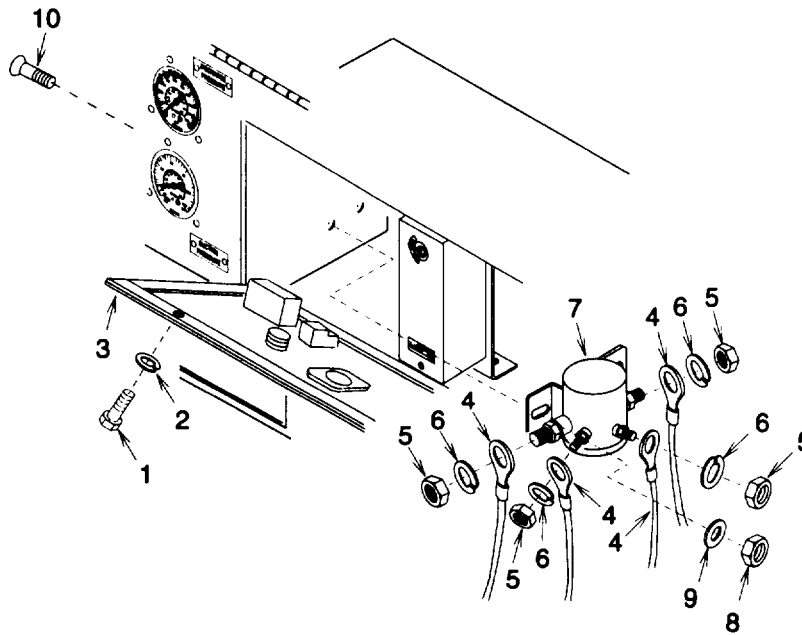

Figure 4-28. Continuous Duty Solenoid

NOTE

Terminal hardware is supplied with continuous duty solenoid.

- (2) Tag wire leads (4) and remove nuts (5), lock washers (6) and wire leads.

4-34. CONTINUOUS DUTY SOLENOID K5 TESTING AND REPLACEMENT .-Continued

- (3) Using multimeter set to measure continuity, check continuous duty solenoid (7) continuity between small terminal lugs. Continuity should be indicated. If continuity was not indicated, replace continuous duty solenoid.
- (4) Using multimeter set to measure continuity, check continuous duty solenoid (7) continuity between large terminal lugs. Continuity should not be indicated. If continuity was indicated, replace continuous duty solenoid.
- (5) Using multimeter set to measure continuity, check continuous duty solenoid (7) continuity between each terminal and the case. No continuity should be indicated. If continuity was indicated, replace continuous duty solenoid.
- (6) If no failure was indicated, install wire leads (4) per tags and wiring diagram (fig. 1-4), lock washers (6), and nuts (5). Remove tags.
- (7) Close control panel (3) and install two new lock washers (2) and bolts (1).

b. Removal.

- (1) Be sure battery has been disconnected then remove two bolts (1) and lock washers (2). Open control panel (3). Discard lock washers.

NOTE

Terminal hardware is supplied with continuous duty solenoid.

- (2) Tag wire leads (4) and remove nuts (5), lock washers (6) and wire leads.
- (3) Remove two self locking nuts (8), flat washers (9), screws (10), and continuous duty solenoid (7). Discard self locking nuts.

c. Installation.

- (1) Install continuous duty solenoid (7), two screws (10), flat washers (9), new self locking nuts (8).

NOTE

Terminal hardware is supplied with continuous duty solenoid.

- (2) Using tags and wiring diagram (fig. 1-4), install wire leads (4), lock washers (6) and nuts (5). Remove tags.
- (3) Close control panel (3). Install two new lock washers (2) and bolts (1).

NOTE**FOLLOW-ON MAINTENANCE:**

Unlatch and close control box cover door. Connect battery (para 4-35) and put unit back into service.

4-35. BATTERY BT TESTING AND REPLACEMENT.

This task covers:

a. Testing**b. Removal****c. Installation****INITIAL SETUP**Materials/Parts:

Self Locking Nuts (4)
 7, Appendix G
 Lock Washers (2)
 2, Appendix G
 Self Locking Nuts (3)
 4, Appendix G
 Lock Washers (10)
 1, Appendix G
 Marker tags (2)
 4, Appendix E

Equipment Conditions:

Refrigeration unit shut down (para 2-7).
 Top access panel removed (para 4-13).
 Right side door open.

General Safety Instructions:**WARNING**

Exposed rotating parts are used in the refrigeration unit.

- a. Testing. (See Figure 1-4.)

NOTE

Access to the battery is best achieved through the top access panel.

- (1) Tag wire leads (1) (positive) and (2) (negative). Pull the black (negative) shield (3) back to expose negative lug (4).

WARNING

Battery explosion and personal injury can occur if negative lug is not removed first or if battery posts are shorted.

NOTE

Hardware is supplied with lug.

- (2) Loosen bolt (5) and carefully remove lug (4) from battery (6).
 (3) Pull the red (positive) shield (7) back to expose positive lug (8).
 (4) Loosen bolt (9) and carefully remove lug (8) from battery (6).
 (5) Using appropriate tester, check battery (6).

4-35. BATTERY BT TESTING AND REPLACEMENT. -Continued

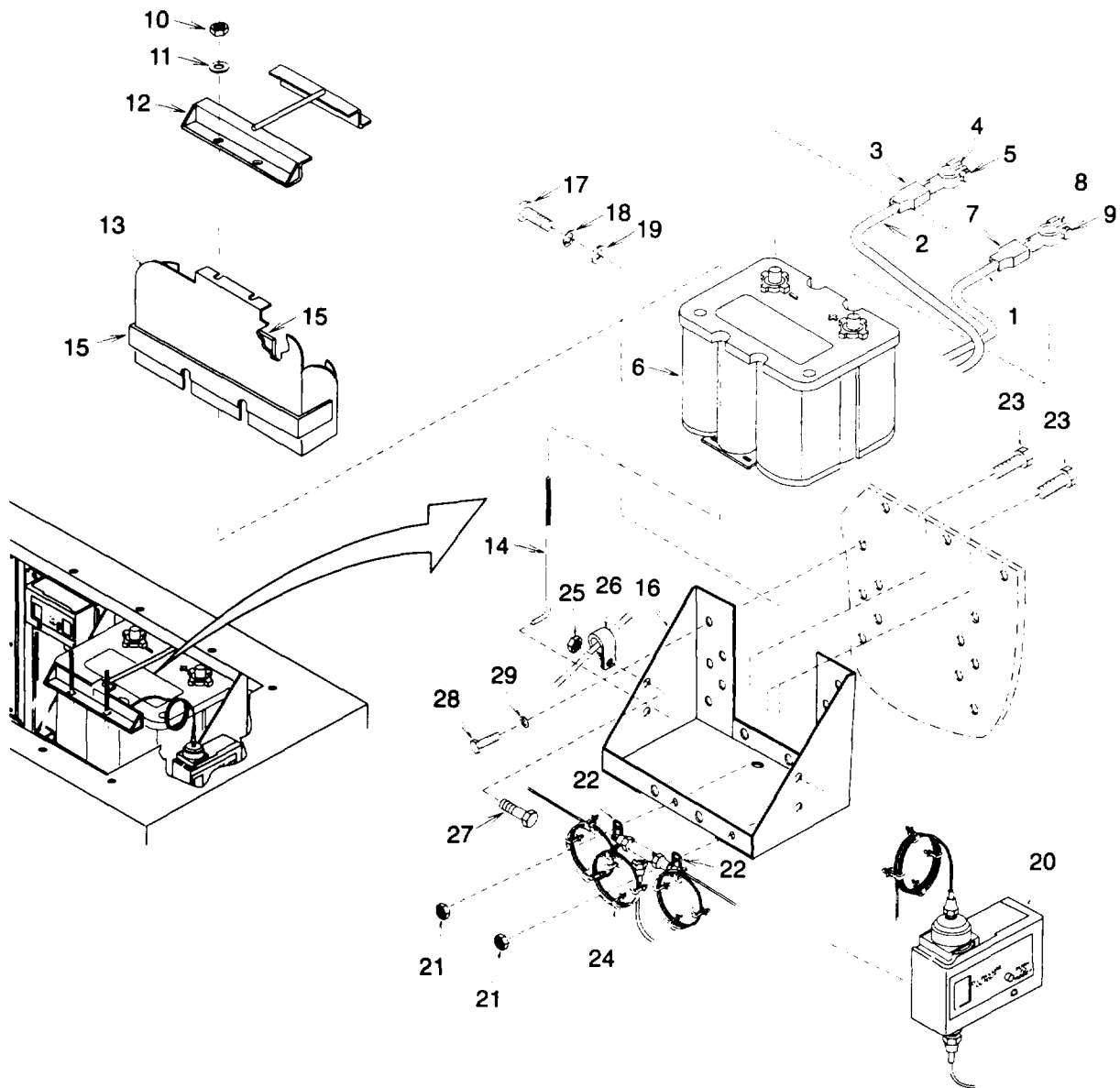

Figure 4-29. Battery

WARNING

Battery explosion and personal injury can occur if positive lug is not installed first or if battery posts are shorted.

- (6) If no failure was indicated, install positive lug (8) using tag and wiring diagram (fig. 1-4) and tighten bolt (9). Cover lug with red (positive) shield (7). Remove tag.
- (7) Install negative lug (4) using tag and wiring diagram (fig. 1-4) and tighten bolt (5). Cover lug with black (negative) shield (3). Remove tag.

b. Removal.

NOTE

Access to battery is best achieved through the top access panel.

- (1) Tag wire leads (1) and (2). Pull the black (negative) shield (3) back to expose negative lug (4).

WARNING

Battery explosion and personal injury can occur if negative lug is not removed first or if battery posts are shorted.

NOTE

Hardware is supplied with lug.

- (2) Loosen bolt (5) and carefully remove lug (4) from battery (6).
- (3) Pull the red (positive) shield (7) back to expose positive lug (8).
- (4) Loosen bolt (9) and carefully remove lug (8) from battery (6).
- (5) Remove four self locking nuts (10), flat washers (11), and battery clamp (12). Discard self locking nuts.

WARNING

Battery can explode and cause injury to personnel and equipment if battery is dropped or punctured. Do not lift battery by terminals.

- (6) Note position of shield (13) and remove battery (6), four L-bolts (14), and shield. If shield gaskets (15) are damaged, notify direct support maintenance to replace them.
- (7) If battery frame (16) is damaged, remove two screws (17), lock washers (18), flat washers (19), and carefully pull differential oil pressure switch (20) away from battery frame. Discard lock washers.
- (8) Remove two self locking nuts (21), clamps (22), and bolts (23). Carefully pull capillary tubing (24) away from battery frame (16). Discard self locking nuts.

4-35. BATTERY BT TESTING AND REPLACEMENT.-Continued

(9) Remove self locking nut (25), clamp (26), and bolt (27). Discard self locking nut.

(10) Remove ten bolts (28), lock washers (29), and batteryframe (16). Discard lock washers.

c. Installation.

NOTE

Access to battery is best achieved through the top access panel.

(1) If removed, install battery frame (16), ten new lock washers (29), and bolts (28).

(2) Install clamp (26), bolt (27), and new self locking nut (25).

(3) Install two clamps (22), bolts (23), and new self locking nuts (21).

(4) Install differential oil pressure switch (20), two flat washers (19), new lock washers (18), and bolts (17).

WARNING

Battery can explode and cause injury to personnel and equipment if battery is dropped or punctured. Do not lift battery by terminals.

(5) Position four L-bolts (14) in the battery frame (16). Install battery (6) and shield (13) as noted during removal.

(6) Install battery clamp (12) over L-bolts (14).

(7) Install four flat washers (11) and new self locking nuts (10).

WARNING

Battery explosion and personal injury can occur if positive lug is not installed first or if battery posts are shorted.

(8) Install positive lug (8) using tag and wiring diagram (fig. 14) and tighten bolt (9). Cover lug with red (positive) shield (7). Remove tag.

(9) Install negative lug (4) using tag and wiring diagram (fig. 1-4) and tighten bolt (5). Cover lug with black (negative) shield (3). Remove tag.

NOTE

FOLLOW-ON MAINTENANCE:

Install top access panel (para 4-13). Close right side door. Put unit back into service.

4-36. TEMPERATURE SWITCH S3 REPLACEMENT.

This task covers:
a. Removal**b. Installation****INITIAL SETUP****Materials/Parts:**

Marker tags (2)
 4, Appendix E
 Tie Down Straps (2)
 8, Appendix E
 Insulation Tape
 6, Appendix E

Equipment Conditions:

Refrigeration unit shut down (para 2-7) and battery disconnected (para 4-35).
 Access panel removed (para 4-16).

a. Removal.

- (1) Remove insulation (1) as necessary.
- (2) Be sure battery has been disconnected, then tag and disconnect two tabs (2).
- (3) Cut two tie down straps (3) and remove defrost temperature switch (4).

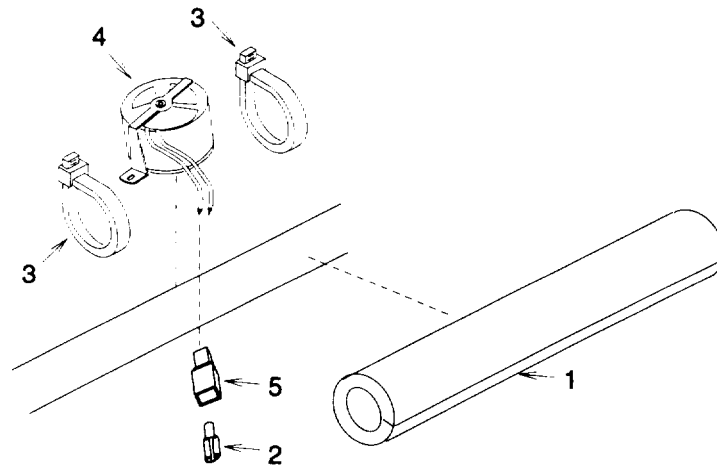
**Figure 4-30. Temperature Switch**

4-36. TEMPERATURE SWITCH S3 REPLACEMENT.-Continued**b. Installation.**

- (1) Install temperature switch (4), and secure using two tie down straps (3).
- (2) Install new tab housing (5) and tab (2) onto each temperature switch (1) wire lead (para 4-19).
- (3) Using tags and wiring diagram (fig. 1-4), connect tabs (2). Remove tags.
- (4) Install any insulation (1) that was removed and secure with insulation tape as necessary.

NOTE**FOLLOW-ON MAINTENANCE:**

Install access panel (para 4-16). Connect battery (para 4-35) and put unit back into service.

4-37. PUSH SWITCHES S9 AND S10 TESTING AND REPLACEMENT.

This task covers:

a. Testing

b. Removal

c. Installation

INITIAL SETUP

Tools:

Heat Gun

3, Section III, Appendix B

Materials / Parts:

Self Locking Nuts (2 Each Push Switch)

6, Appendix G

Sleeving Insulation (1 Each Push Switch)

1, Figure F-6, Appendix F

Sleeving Insulation (1 Each Push Switch)

2, Figure F-6, Appendix F

Marker tags (4)

4, Appendix E

Equipment Conditions:

Refrigeration unit shut down (para 2-7) and battery disconnected (para 4-35).

Both side doors open.

General Safety Instructions:

WARNING

Exposed rotating parts are used in the refrigeration unit. Personal injury can result if battery is connected.

a. Testing.

(1) Remove sleeving insulation (1).

(2) Tag and disconnect wire leads (2).

(3) Using multimeter set to measure continuity, check push switch (3) contact continuity across terminals C and NO with the push button switch out and pushed in. Continuity should only be indicated with the switch pushed in. If continuity was not indicated when switch was pushed in or was indicated with switch out, replace push switch.

NOTE

Smaller diameter sleeving insulation must go over wire lead connecting to push switch terminal C.

(4) If no failure was indicated, install insulation sleeving (1) over wire leads (2).

4-37. PUSH SWITCHES S9 AND S10 TESTING AND REPLACEMENT. - Continued

(5) Using tags and wiring diagram (fig. 1-4), connect wire leads (2). Remove tags.

NOTE

Sleeving insulation covers only terminal C on one side of push switch, but must cover both terminals NO and NC on the other side.

(6) Slip sleeving insulation (1) over exposed terminals and shrink in place using heat gun.

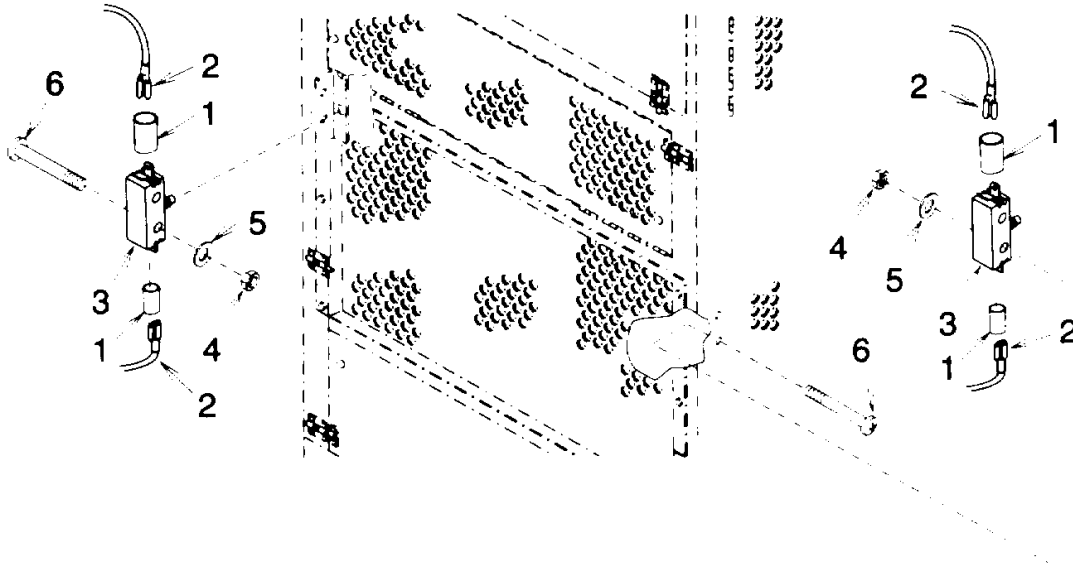

Figure 4-31. Push Switches

b. Removal.

- (1) Remove sleeving insulation (1).
- (2) Tag and disconnect wire leads (2).
- (3) Remove two self locking nuts (4), flat washers (5), bolts (6), and push switch (3). Discard self locking nuts.

c. Installation.

- (1) Install push switch (3), two bolts (6), flat washers (5), and new self locking nuts (4).

NOTE

Smaller diameter sleeving insulation must go over wire lead connecting to push switch terminal C.

- (2) Install insulation sleeving (1) over wire leads (2).
- (3) Using tags and wiring diagram (fig. 1-4), connect wire leads (2). Remove tags.

NOTE

Sleeving insulation covers only terminal C on one side of push switch, but must cover both terminals NO and NC on the other side.

- (4) Slip sleeving insulation (1) over exposed terminals and shrink in place using heat gun.

NOTE

FOLLOW-ON MAINTENANCE:

Close both side doors.

Connect battery (para 4-35) and put unit back into service.

4-38. V-BELTS REPLACEMENT AND ADJUSTMENT.

This task covers:

a. Removal**b. Installation****c. Adjustment****INITIAL SETUP**Materials/Parts:

Lock Washers (8)
1, Appendix G

Equipment Conditions:

Refrigeration unit shut down (para 2-7) and battery disconnected (para 4-35).
Both side doors open.

General Safety Instructions:**WARNING**

Exposed rotating parts are used in the refrigeration unit. Personal injury can result if battery is connected.

a. Removal.**(1) Fan -Belt.**

- (a) Remove eight bolts (1), lock washers (2), and belt access plate (3).
- (b) Tag and disconnect connectors (4).
- (c) Loosen bolt (5) as necessary to release tension on V-belt (6).
- (d) Remove -belt (6) from compressor pulley (7).
- (e) Work -belt (6) around condenser fan (8) and remove.

(2) Compressor V-Belts.

- (a) Remove fan V-belt (6) per above steps.
- (b) Loosen four bolts (9).
- (c) Turn swivel bolt (10) clockwise as necessary to release tension on two V-belts (11) and remove belts.

b. Installation.**(1) Compressor -Belts.**

- (a) Install two V-belts (11) onto the engine pulley (12) and compressor pulley (7).
- (b) Install fan belt per steps below.
- (c) Adjust tension per steps below.

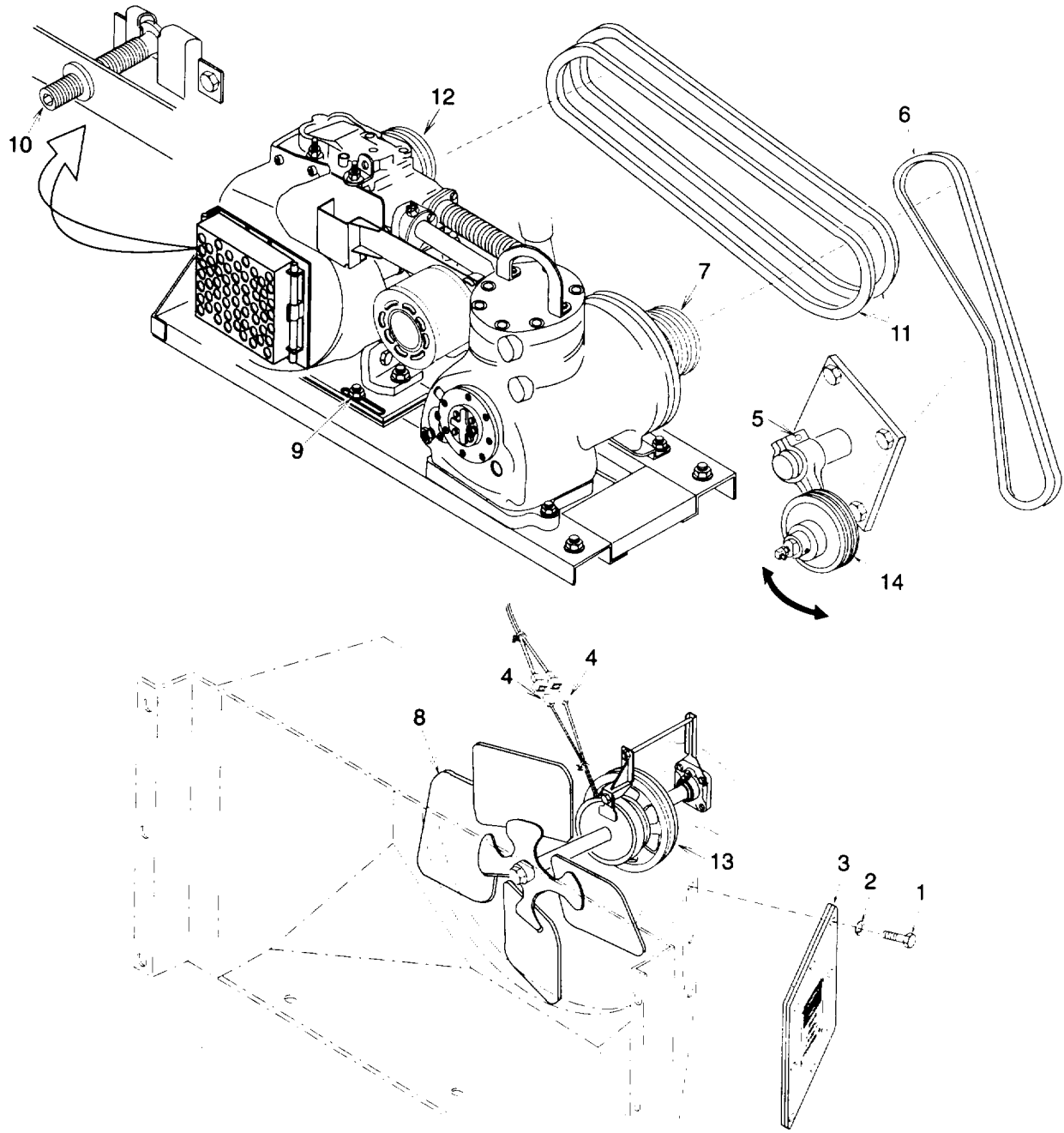

Figure 4-32. V-Belt

4-38. V-BELTS REPLACEMENT AND ADJUSTMENT. - Continued**(2) Fan V-Belt.**

- (a) Work V-belt (6) around condenser fan (8).
- (b) Slip V-belt (6) onto clutch (13) and compressor pulley (7).
- (c) Adjust tension per steps below.
- (d) Using tags and wiring diagram (fig. 1-4), attach connectors (4). Remove tags.

c. Adjustment.

- (1) Remove eight bolts (1), lock washers (2), and belt access plate (3).

CAUTION

Too little tension causes slippage or slip and grab, causing the belt to break. If the belt does not break, the slip will cause excessive cover wear, burn spots and overheating. Too much tension can cause belt heating and excessive stretch, as well as damage to drive components, such as sheaves and shafts. Excessive tightness will also place heavier loads on the bearings causing them to fail prematurely.

(2) Compressor V-Belt.

- (a) Turn swivel bolt (10) counterclockwise to set V-belts (11) tension.
- (b) Belt tension is correct when 4 lb (2 kg) force is applied to the mid point of the V-belt and it deflects 0.38 in. (1 cm). When the correct tension is reached, tighten four bolts (9).

(3) Fan Belt.

- (a) Be sure idler pulley (14) is centered under V-belt (6).
 - (b) Push on idler pulley to set V-belt tension. Belt tension is correct when 4 lb (2 kg) force is applied to the mid point of the belt and it deflects 0.38 in. (1 cm). When the correct tension is reached, tighten bolt (5).
- (3) Install belt access plate (3), eight new lock washers (2) and bolts (1).

NOTE**FOLLOW-ON MAINTENANCE:**

Close both side doors.

Connect battery (para 4-35) and put unit back into service.

4-39. ENGINE PULLEY REPLACEMENT.

This task covers:

a. Removal

b. Installation

INITIAL SETUPEquipment Conditions:

Refrigeration unit shut down (para 2-7) and battery disconnected (para 4-35).

V-belts removed from engine only (para 4-38).
refrigeration unit.

General Safety Instructions:**WARNING**

Exposed rotating parts are used in the refrigeration unit. Personal injury can result if Battery is connected

a. Removal.

(1) Remove three bolts (1), and install two bolts back into threaded holes in bushing (2). Tighten bolts evenly to separate bushing from pulley (3). Remove two bolts from bushing.

(2) Slide bushing (2) and pulley (3) off engine drive shaft (4) being careful not to lose keys (5) and (6).

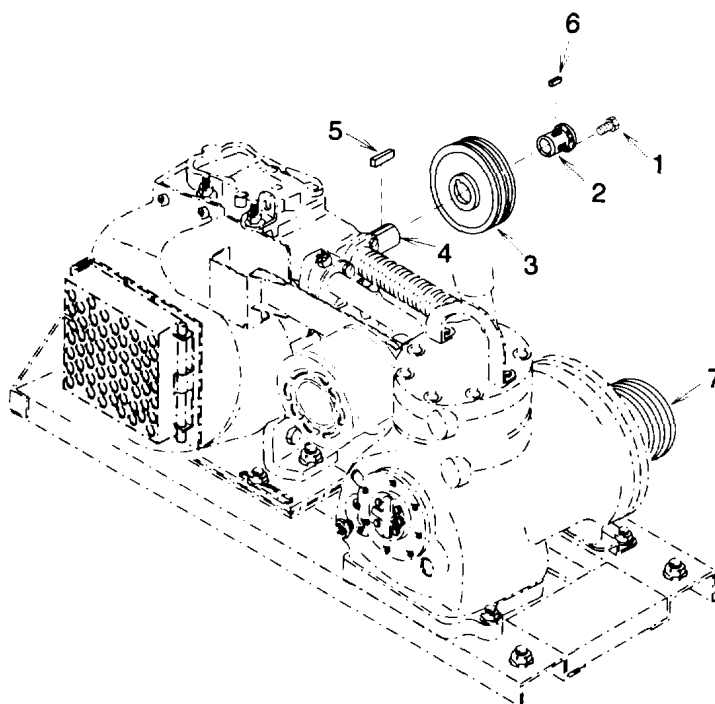

Figure 4-33. Engine Pulley

4-39. ENGINE PULLEY REPLACEMENT. - Continued**b. Installation.**

- (1) Install key (5) then slide pulley (3) and bushing (2) onto engine shaft (4). Align bushing over key.
- (2) Install key (6) then align pulley (3) with key and slide onto bushing (2).
- (3) Install three bolts (1) but do not tighten.
- (4) Align engine pulley (3) with compressor pulley (7). Tighten three bolts (1) evenly to secure pulley to bushing (2).

NOTE**FOLLOW-ON MAINTENANCE:**

Install V-belts onto pulley and engine, then tension as necessary (para 4-38).
Connect battery (para 4-35) and put unit back into service.

4-40. IDLER PULLEY REPLACEMENT.**This task covers:****a. Removal****b. Installation****INITIAL SETUP**Materials/ Parts:

Lock Washers (4)
2, Appendix G
Lock Washers (8)
1, Appendix G

Equipment Conditions:

Refrigeration unit shut down (para 2-7) and battery disconnected (para 4-35).

General Safety Instructions:**WARNING**

Exposed rotating parts are used in the refrigeration unit. Personal injury can result if battery is connected.

a. Removal.

- (1) Remove eight bolts (1), lock washers (2), and access plate (3). Discard lock washers.
- (2) Loosen bolt (4) to relax tension on fan V-belt (5). Work fan V-belt off compressor pulley.
- (3) Slide idler arm (6) off idler bracket (7).
- (4) Loosen set screw (8), then slide bushing (9) and idler pulley (10) off idler shaft (11).

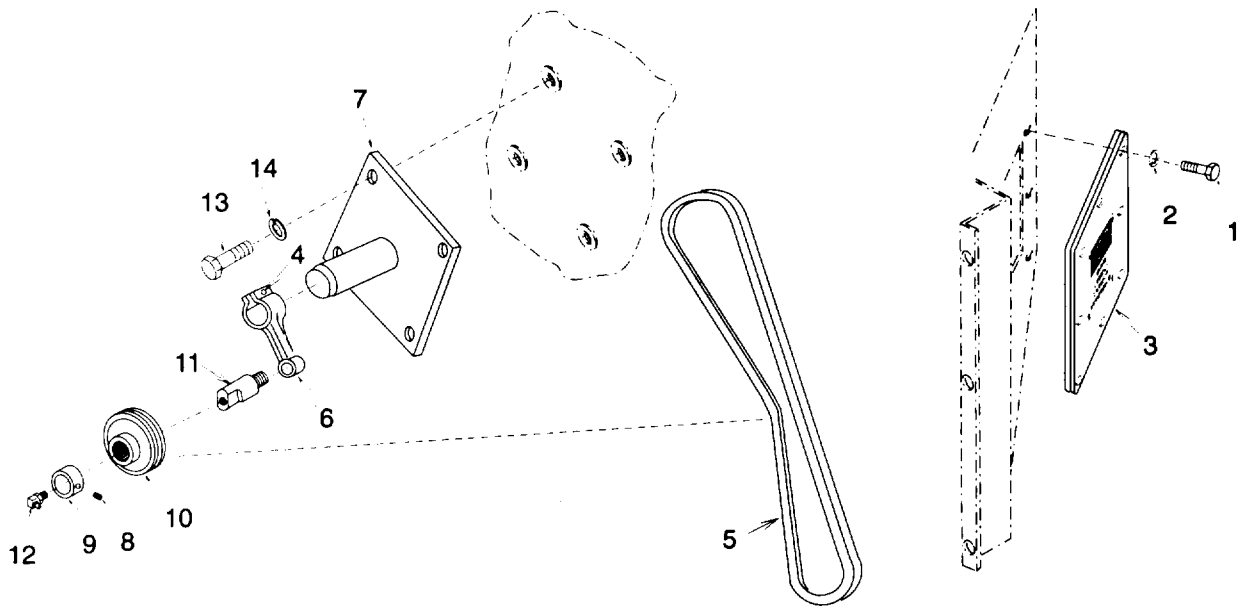

Figure 4-34. Idler Pulley

- (5) If idler shaft (11) is damaged, remove it from idler arm (6). If lubrication fitting (12) is damaged remove it from idler shaft.
- (6) If idler bracket (7) is damaged, remove four bolts (13), lock washers (14), and idler bracket. Discard lock washers.

b. Installation.

- (1) If removed, install idler bracket (7), four new lock washers (14), and bolts (13).
- (2) If removed, install idler shaft (11) onto idler arm (6) and lubrication fitting (12) into idler shaft.
- (3) Slide idler pulley (10) onto idler shaft (11) then slide bushing (9) onto idler shaft and tighten set screw (8).
- (4) Slide idler arm (6) onto idler bracket (7).
- (5) Be sure idler pulley (10) is centered under fan V-belt (5). Push on idler pulley to set fan V-belt tension. Belt tension is correct when 4 lb (2 kg) force is applied to the mid point of the belt and it deflects 0.38 in. (1 cm). When the correct tension is reached, tighten bolt (4).
- (6) Install access plate (3), eight new lock washers (2), and bolts (1).

NOTE

**FOLLOW-ON MAINTENANCE:
Connect battery (para 4-35) and put unit back into service.**

4-41. CONDENSER FAN REPLACEMENT.

This task covers:

a. Pre-Inspection

b. Removal

c. Cleaning.

INITIAL SETUP

Materials/Parts:

Lock Washer (8)

1, Appendix G

Lock Washer

2, Appendix G

Equipment Conditions:

Refrigeration unit shut down (para 2-7) and battery disconnected (para 4-35).

Right side door open.

Fuel tank removed (para 4-67).

General Safety Instructions:

WARNING

Exposed rotating parts are used in the refrigeration unit. Personal injury can result if battery is connected.

a. Removal.

(1) Remove eight bolts (1), lock washers (2), and access plate (3). Discard lock washers.

(2) Remove bolt (4), lock washer (5), flat washer (6), and cap (7). Discard lock washer.

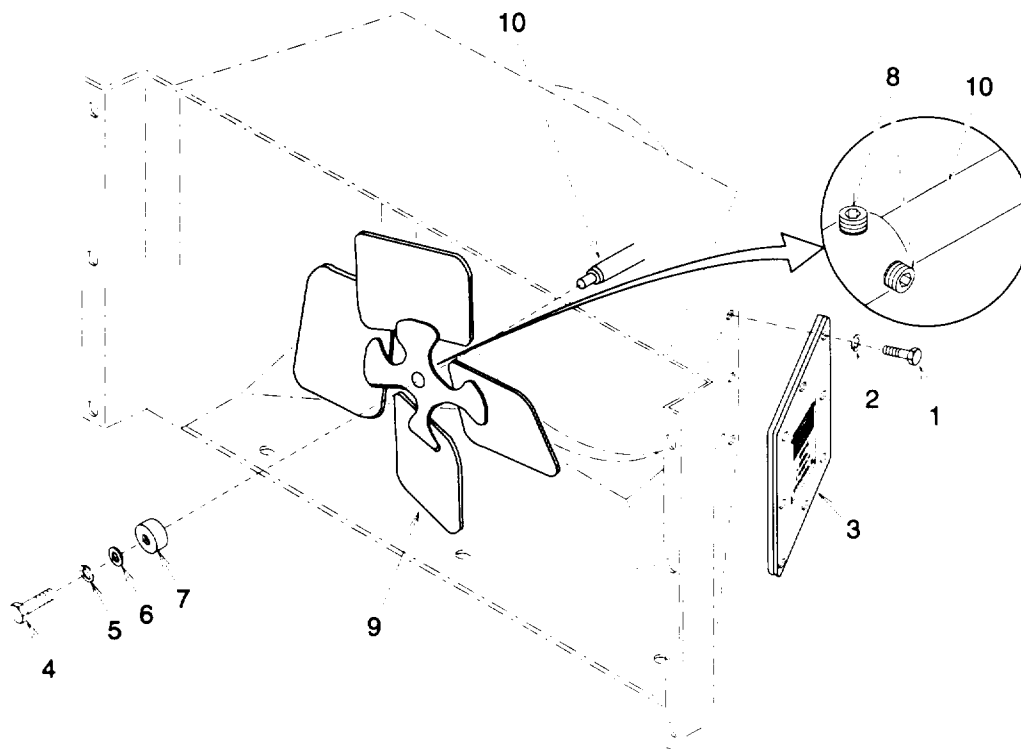

Figure 4-35. Condenser Fan

(3) Loosen two set screws (8).

(4) Carefully pull condenser fan (9) off fan drive shaft (10) and remove.

b. Installation.

(1) Install condenser fan (9) onto fan drive shaft (10).

(2) Tighten two set screws (8) against flat surfaces on fan drive shaft (10).

(3) Install cap (7), flat washer (6), new lock washer (5), and bolt (4).

(4) Install access plate (3), eight new lock washers (2), and bolts (1).

NOTE

FOLLOW-ON MAINTENANCE:

Install fuel tank (para 4-67).

Close right side door.

Connect battery (para 4-35) and put unit back into service.

4-42. EVAPORATOR FAN REPLACEMENT.**This task covers:****a. Removal****b. Installation****INITIAL SETUP**General Safety Instructions:Equipment Conditions:

Refrigeration unit shut down (para 2-7) and battery disconnected, para 4-35).

Evaporator cover panel removed (para 4-15).

WARNING**Exposed rotating parts are used in the refrigeration unit. Personal injury can result if battery is connected.****a. Removal.**

- (1) Loosen two set screws (1).
- (2) Carefully pull evaporator fan (2) off fan drive shaft (3) and remove.

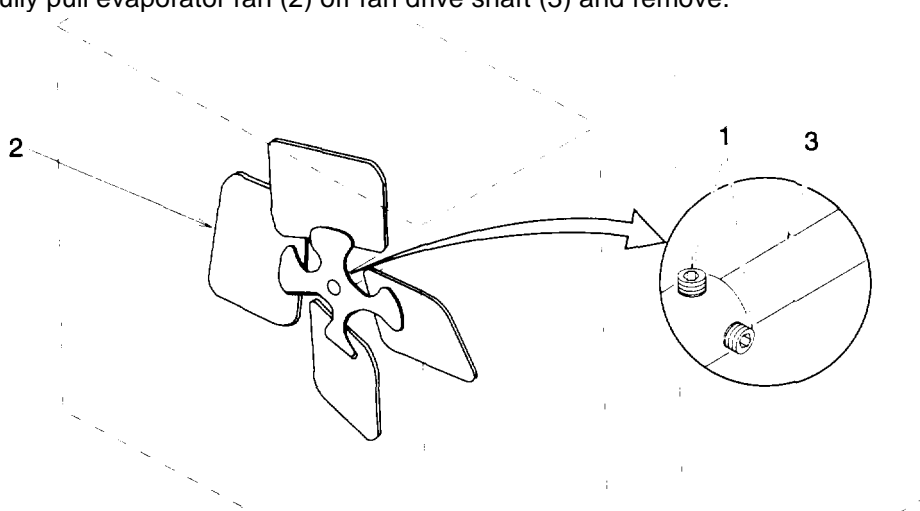
**Figure 4-36. Evaporator Fan****b. Installation.**

- (1) Install evaporator fan (2) onto fan drive shaft (3).
- (2) Tighten two set screws (1) against flat surfaces on fan drive shaft (3).

NOTE

FOLLOW-ON MAINTENANCE:
Install evaporator cover panel (par 4-15).
Connect battery (para 4-35) and put unit back into service.

4-43. FLANGE BEARING (CONDENSER FAN) REPLACEMENT.**This task covers:****a. Removal****b. Installation****INITIAL SETUP**Materials/Parts:

Lock Washers (4)

8, Appendix G

Equipment Conditions:

Refrigeration unit shut down (para 2-7) and battery disconnected (para 4-35).

Fan Clutch removed (para 4-46).

General Safety Instructions:**WARNING****Exposed rotating parts are used in the refrigeration unit. Personal injury can result if battery is connected.****a. Removal.**

- (1) Remove four bolts (1), lock washers (2), and bracket (3). Discard lock washers.
- (2) Loosen two set screws (4).
- (3) Slide flange bearing (5) off fan drive shaft (6).

NOTE**A new flange bearing is supplied with a straight lubrication fitting that must be replaced with a 900 fitting.**

- (4) Remove lubrication fitting (7) and retain for use during installation.

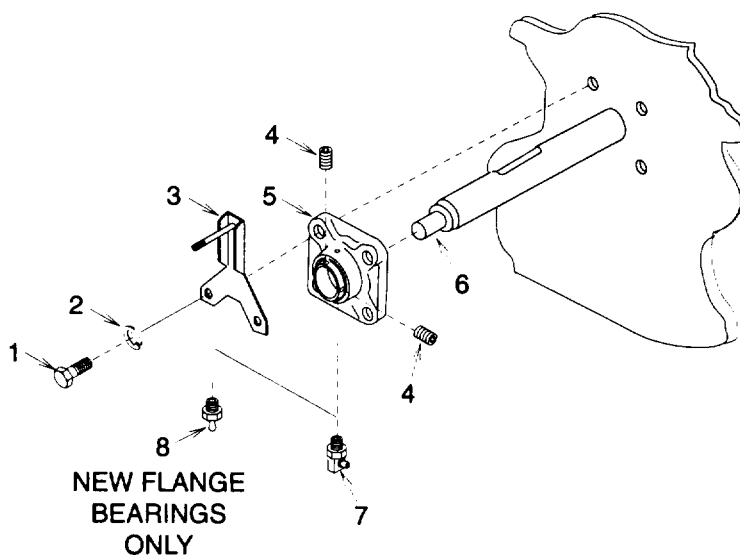
**Figure 4-37. Flange Bearing (Condenser Fan)**

4-43. FLANGE BEARING (CONDENSER FAN) REPLACEMENT . - Continuedb. Installation.**NOTE**

A new flange bearing is supplied with a straight lubrication fitting that must be replaced with a 900 fitting.

- (1) Remove straight lubrication fitting (8) from new flange bearing (5) and install 90° lubrication fitting (7).
- (2) Slide flange bearing (5) onto fan drive shaft (6). Be sure lubrication fitting (7) is facing down.
- (3) Install bracket (3), four new lock washers (2), and bolts (1).
- (4) Tighten two set screws (4).

NOTE

**FOLLOW-ON MAINTENANCE:
Install fan clutch (para 4-46).
Connect battery (para 4-35) and put unit back into service.**

4-44. FLANGE BEARING (EVAPORATOR FAN) REPLACEMENT .**This task covers:****a. Removal****b. Installation****INITIAL SETUP**Materials/Parts:

Self Locking Nuts (4)
10, Appendix G

Equipment Conditions:

Refrigeration unit shut down (para 2-7) and battery disconnected (para 4-35).
Evaporator fan removed (para 4-42).

General Safety Instructions:**WARNING**

Exposed rotating parts are used in the refrigeration unit. Personal injury can result if battery is connected.

a. Removal.

- (1) Remove four self locking nuts (1), flat washers (2), bolts (3), and flat washers (4). Discard self locking nuts.
- (2) Loosen two set screws (5) and slide flange bearing (6) off fan drive shaft (7).
- (3) Remove flange bearing (6) from lubrication fitting extension (8).

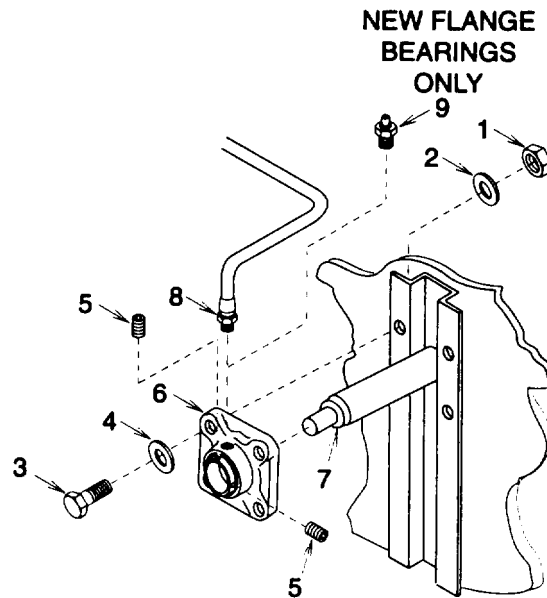

Figure 4-38. Flange Bearing (Evaporator Fan)

b. Installation

NOTE

A new flange bearing is supplied with a lubrication fitting that must be removed.

- (1) Remove lubrication fitting (9).
- (2) Install flange bearing (6) onto lubrication fitting extension (8).
- (3) Slide flange bearing (6) onto fan drive shaft (7).
- (4) Install four flat washers (4), bolts (3), flat washers (2) and new self locking nuts (1).
- (5) Tighten two set screws (5).

NOTE

FOLLOW-ON MAINTENANCE:
Install evaporator fan (para 4-42).
Install evaporator cover panel (para 415).
Connect battery (para 4-35) and put unit back into service.

4-45. GREASE FITTING EXTENSION REPLACEMENT.**This task covers:****a. Removal****b. Installation****INITIAL SETUP**Materials/Parts:Self Locking Nut
4, Appendix GEquipment Conditions:Refrigeration unit shut down (para 2-7) and battery
Refrigeration unit shut down (para 2-7) and
disconnected (para 4-35).
Right side door open.General Safety Instructions:**WARNING****Exposed rotating parts are used in the
refrigeration unit. Personal injury can result if
battery is connected.****a. Removal.****NOTE****Grease fitting is not supplied with grease fitting extension.**

- (1) Remove grease fitting (1) and retain for use during installation.
- (2) Remove self locking nut (2), bolt (3), and clamp (4). Discard self locking nut.
- (3) Remove two grommets (5).
- (4) Pull grease fitting extension (6) through enclosure then remove.

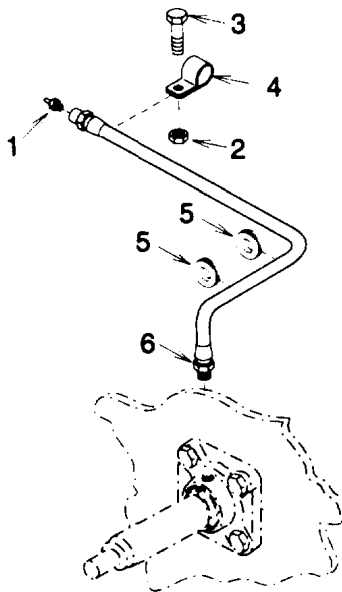
**Figure 4-39. Grease Fitting Extension**

b. Installation.

- (1) Install grease fitting extension (6), then route through enclosure opening.
- (2) Install two grommets (5).
- (3) Install clamp (4), bolt (3), and new self locking nut (2).
- (4) Install grease fitting (1).

NOTE

FOLLOW-ON MAINTENANCE:
Close right side door.
Connect battery (para 4-35) and put unit back into service.

4-46. FAN CLUTCH C1 TESTING AND REPLACEMENT.

This task covers:

a. Testing

b. Removal

c. Installation

INITIAL SETUP

Materials/Parts:

Self Locking Nut
 9, Appendix G
 Lock Washers (2) (Clutch Bracket)
 2, Lock Washers (8)

1, Appendix G
 Lock Washer (Condenser Fan)
 2, Appendix G

Equipment Conditions:

Refrigeration unit shut down (para 2-7) and battery disconnected (para 4-35).
 Right side door open.

General Safety Instructions:

WARNING

Exposed rotating parts are used in the refrigeration unit. Personal injury can result if battery is connected.

a. Testing.

- (1) Tag and disconnect two connectors (1).
- (2) Using multimeter set to measure continuity, check fan clutch (2) continuity between connectors. Continuity should be indicated. If no continuity was indicated, replace fan clutch.
- (3) If no failure was indicated, attach connectors (1) using tags and wiring diagram (fig. 1-4). Remove tags.

4-46. FAN CLUTCH C1 TESTING AND REPLACEMENT . - Continuedb. Removal.

- (1) Remove eight bolts (3), lock washers (4), and belt access plate (5). Discard lock washers.
- (2) Remove bolt (6), lock washer (7), flat washer (8), and cap (9). Discard lock washer.
- (3) Loosen two set screws (10).
- (4) Carefully pull condenser fan (11) off fan drive shaft (12) being careful not to damage condenser coil (13). Leave fan in condenser shroud (14).
- (5) Tag and disconnect two connectors (1).
- (6) Loosen bolt (15) to relax tension on V-belt (16).
- (7) Work V-belt (16) off fan clutch (2).
- (8) Remove self locking nut (17) and bolt (18). Discard self locking nut.
- (9) Remove nut (19), lock washer (20), flat washer (21), clutch bracket (22), flat washer (23), lock washer (24) and nut (25). Discard lock washers.
- (10) Loosen two set screws (26) and slide fan clutch (2) off fan drive shaft (12) being careful not to lose key (27).

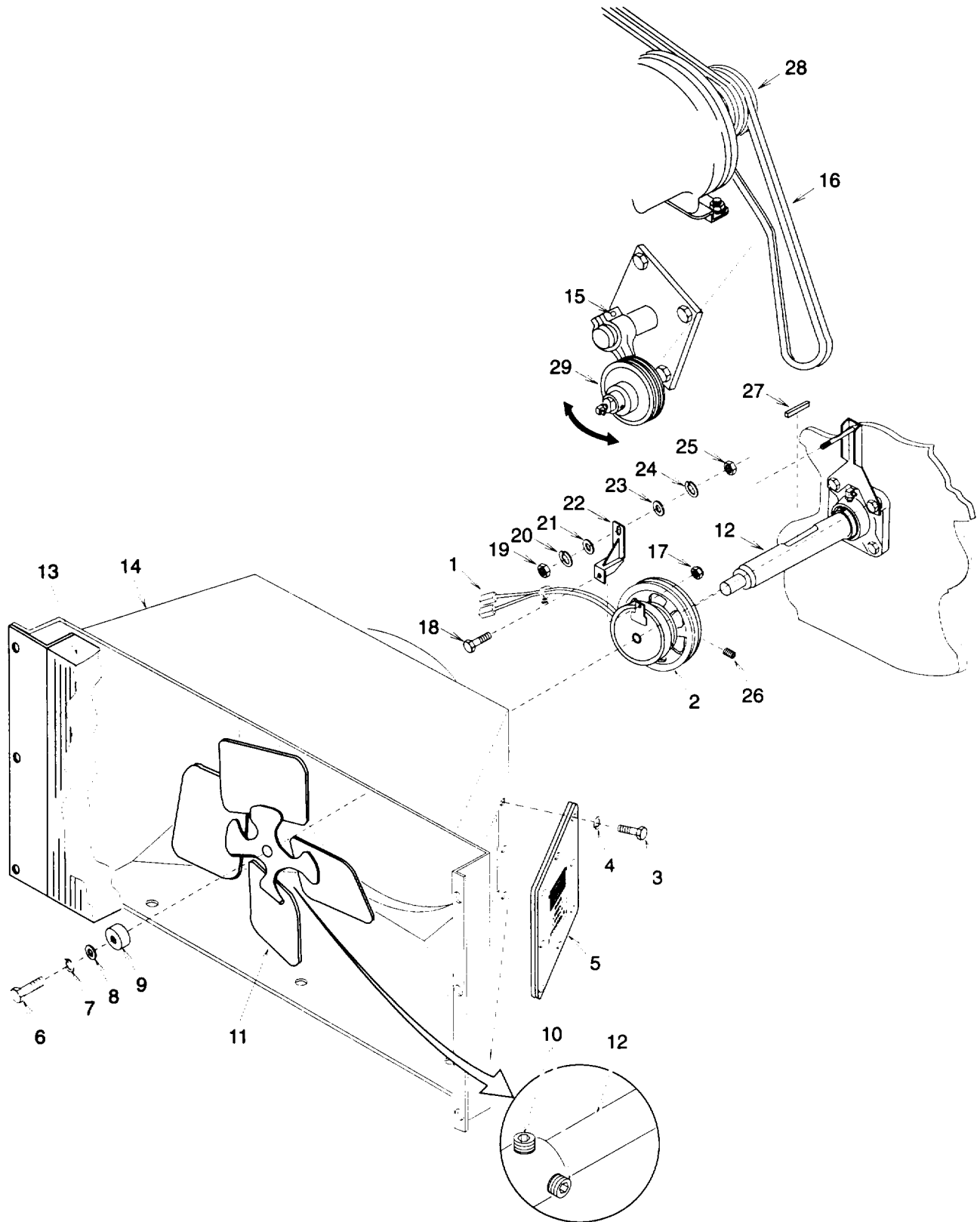

Figure 4-40. Fan Clutch

4-46. FAN CLUTCH C1 TESTING AND REPLACEMENT. - Continuedc. Installation.

- (1) Install key (27) and fan clutch (2) onto fan drive shaft (12). Do not tighten set screws (26).
- (2) Install nut (25), new lock washer (24), flat washer (23), clutch bracket (22), flat washer (21), new lock was (20), and nut (19). Do not tighten nuts.
- (3) Install bolt (18) and new self locking nut (17).
- (4) Work V-belt (16) onto fan clutch (2).
- (5) Using tags and wiring diagram (fig. 1-4), attach connectors (1). Remove tags.
- (6) Install condenser fan (11) onto fan drive shaft (12).
- (7) Tighten two set screws (10) against flats on fan drive shaft (12).
- (8) Install cap (9), flat washer (8), new lock washer (7), and bolt (6).
- (9) Adjust nuts (19) and (25) as necessary to align fan clutch (2) with compressor pulley (28). Tighten nuts.
- (10) Tighten two set screws (26).
- (11) Be sure idler pulley (29) is centered under V-belt (16). Push on idler pulley to set V-belt tension. Belt tension is correct when 4 lb (2 kg) force is applied to the mid point of the V-belt and it deflects 0.38 in. (1 cm). When the correct tension is reached, tighten bolt (15).
- (12) Install belt access plate (5), eight new lock washers (4) and bolts (3).

NOTE**FOLLOW-ON MAINTENANCE:****Close right side door.****Connect battery (para 4-35) and put unit back into service.**

4-47. SOLENOID VALVE L1 (LIQUID LINE) TESTING AND REPAIR.

This task covers:

a. Testing

b. Removal

c. Installation.

INITIAL SETUP

Materials/Parts:

Marker tags (2)
4, Appendix E

Equipment Conditions:

Refrigeration unit shut down (para 2-7) and battery disconnected (para 4-35).
Left side door open.

General Safety Instructions:

WARNING

Exposed rotating parts are used in the refrigeration unit. Personal injury can result if battery is connected.

a. Testing.

- (1) Tag and disconnect tabs (1).
- (2) Using multimeter set to measure continuity, check coil (2) continuity between tabs (1). Continuity should be indicated. If no continuity was indicated, replace coil.
- (3) Using multimeter set to measure continuity, check coil (2) continuity between each tab (1) and coil (2) metal case. No continuity should be indicated. If continuity was indicated, replace coil.

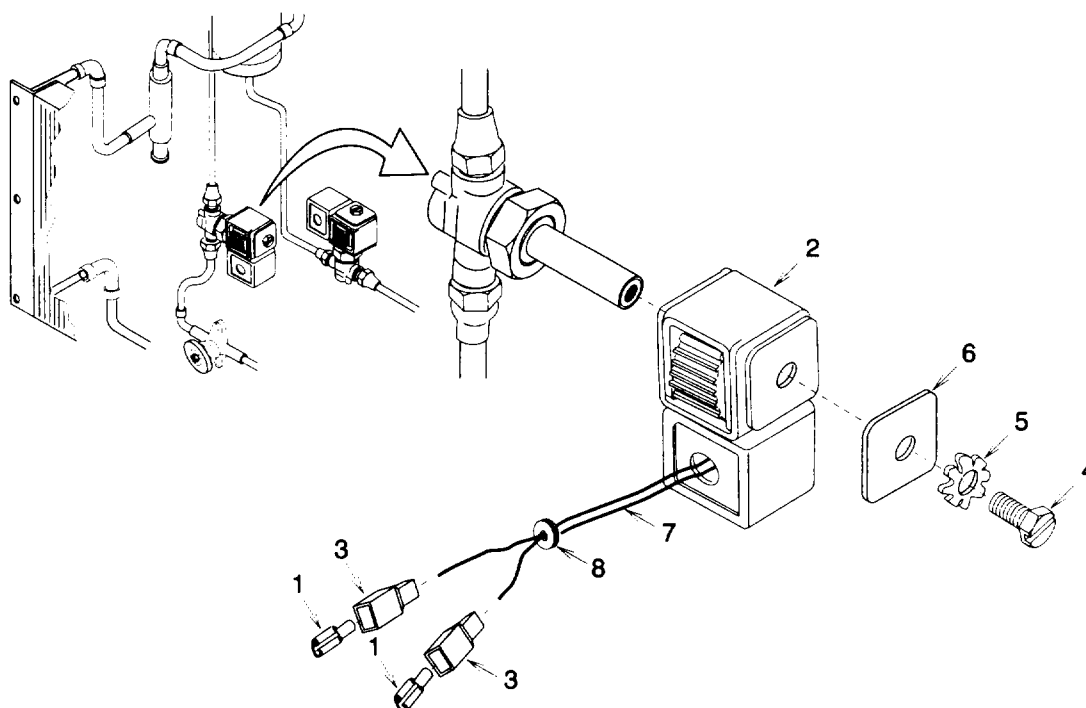

Figure 4-41. Solenoid Valve (Liquid Line)

4-47. SOLENOID VALVE L1 (LIQUID LINE) TESTING AND REPAIR. - Continued

- (4) If no failure was indicated, check tabs (1) and tab housing (3). If damaged, repair or replace per paragraph 4-19.
- (5) Using tags and wiring diagram (fig. 1-4), connect tabs (1). Remove tags.

NOTE

The only authorized repair to the solenoid valve is coil replacement. The coil can be replaced without opening the refrigeration pressure system.

b. Removal.**WARNING**

Do not attempt any disassembly of the solenoid valve other than coil removal with a refrigerant charge in the system. Refrigerant will be sprayed out dangerously if the screws that attach the tube and plunger assembly to the valve body are loosened.

- (1) Tag and disconnect tabs (1).

NOTE

Mounting hardware is not supplied with coil. Screw and lock washer must be retained for use during installation of coil.

- (2) Remove screw (4), lock washer (5), data plate (6), and coil (2).

- (3) Cut wire leads (7) if necessary and remove grommet (8).

c. Installation.

- (1) Push wire leads (7) through grommet (8) and install grommet into coil (2).

- (2) Install two tab housings (3) and tabs (1) (para 4-19).

NOTE

Mounting hardware is not supplied with coil. Screw and lock washer must be retained for use during installation of coil.

- (3) Install coil (2), data plate (6), lock washer (5), and screw (4).

- (4) Using tags and wiring diagram (fig. 1-4), connect tabs (1). Remove tags.

NOTE

**FOLLOW-ON MAINTENANCE:
Close left side door.
Connect battery (para 4-35) and put unit back into service.**

4-48. SOLENOID VALVE L2 (DEFROST LINE) TESTING AND REPAIR.**This task covers:****a. Testing****b. Removal****c. Installation****INITIAL SETUP**Materials/Parts:

Marker tags (2)
4, Appendix E

Equipment Conditions:

Refrigeration unit shut down (para 2-7) and battery disconnected (para 4-35).
Right side condenser door open.

General Safety Instructions:**WARNING**

Exposed rotating parts are used in the refrigeration unit. Personal injury can result if battery is connected.

a. Testing.

- (1) Tag and disconnect tabs (1).
- (2) Using multimeter set to measure continuity, check coil (2) continuity between tabs (1). Continuity should be indicated. If no continuity was indicated, replace coil.
- (3) Using multimeter set to measure continuity, check coil (2) continuity between each tab (1) and coil (2) metal case. No continuity should be indicated. If continuity was indicated, replace coil.
- (4) If no failure was indicated, check tabs (1) and tab housing (3). If damaged, repair or replace per paragraph 4-19.
- (5) Using tags and wiring diagram (fig. 1-4), connect tabs (1). Remove tags.

NOTE

The only authorized repair to the solenoid valve is coil replacement. The coil can be replaced without opening the refrigeration pressure system.

b. Removal.**WARNING**

Do not attempt any disassembly of the solenoid valve other than coil removal with a refrigerant charge in the system. Refrigerant will be sprayed out dangerously if the screws that attach the tube and plunger assembly to the valve body are loosened.

- (1) Tag and disconnect tabs (1).

4-47. SOLENOID VALVE L2 (DEFROST LINE) TESTING AND REPAIR . - Continued

Figure 4-42. Solenoid Valve (Defrost Line)

NOTE

Mounting hardware is not supplied with coil. Screw and lock washer must be retained for use during installation of coil.

- (2) Remove screw (4), lock washer (5), data plate (6), and coil (2).
- (3) Cut wire leads (7) if necessary and remove grommet (8).

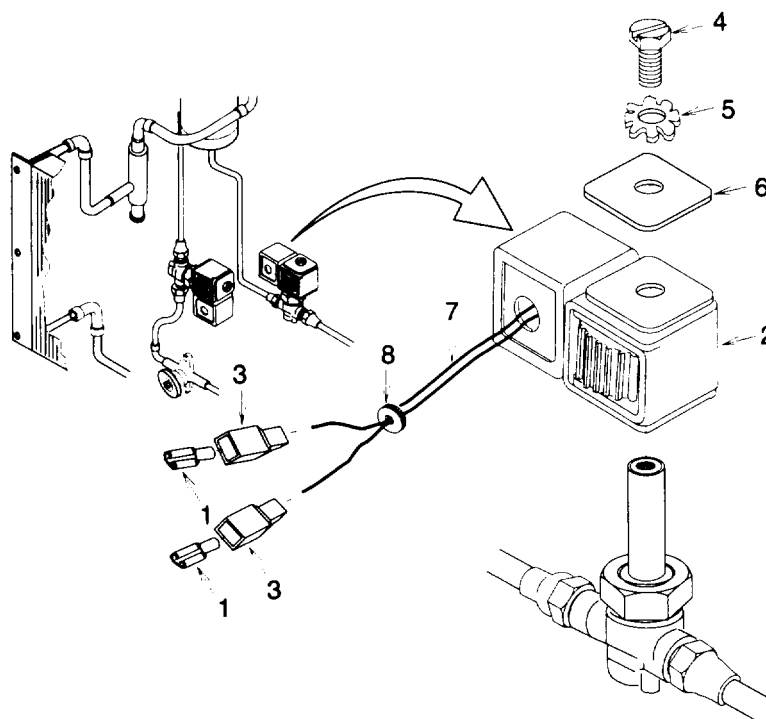
c. Installation.

- (1) Push wire leads (7) through grommet (8) and install grommet into coil (2).
- (2) Install two tab housings (3) and tabs (1) (para 4-19).
- (3) Install coil (2), data plate (6), lock washer (5), and screw (4).
- (4) Using tags and wiring diagram (fig. 14), connect tabs (1). Remove tags.

NOTE

FOLLOW-ON MAINTENANCE:
Close right side condenser door.
Connect battery (para 4-35) and put unit back into service.

4-49. OIL FILTER REPLACEMENT.

This task covers:**a. Removal****b. Installation**

INITIAL SETUPMaterials/Parts:

Wiping Rags
9, Appendix E
Lubricating Oil
10, Appendix E

Equipment Conditions:

Refrigeration unit shut down (para 2-7) and battery disconnected (para 4-35).
Left side door open.

General Safety Instructions:**WARNING**

Exposed rotating parts are used in the refrigeration unit. Personal injury can result if battery is connected.

a. Removal.

- (1) Remove filter element (1) and seal (2). Discard filter element and seal.
- (2) Check condition of union (3) and remove if damaged.

b. Installation.

- (1) Using wiping rag, clean any oil residue remaining.
- (2) Install union (3) if removed.

NOTE**Seal is supplied with new filter element.**

- (3) Lightly coat new seal (2) with lubricating oil and install onto new filter element (1).

4-49. OIL FILTER REPLACEMENT. - Continued

Figure 4-43. Oil Filter

CAUTION

Never install a used filter element onto the engine. Damage to engine can result if filter element is clogged.

- (4) Install new filter element (1).

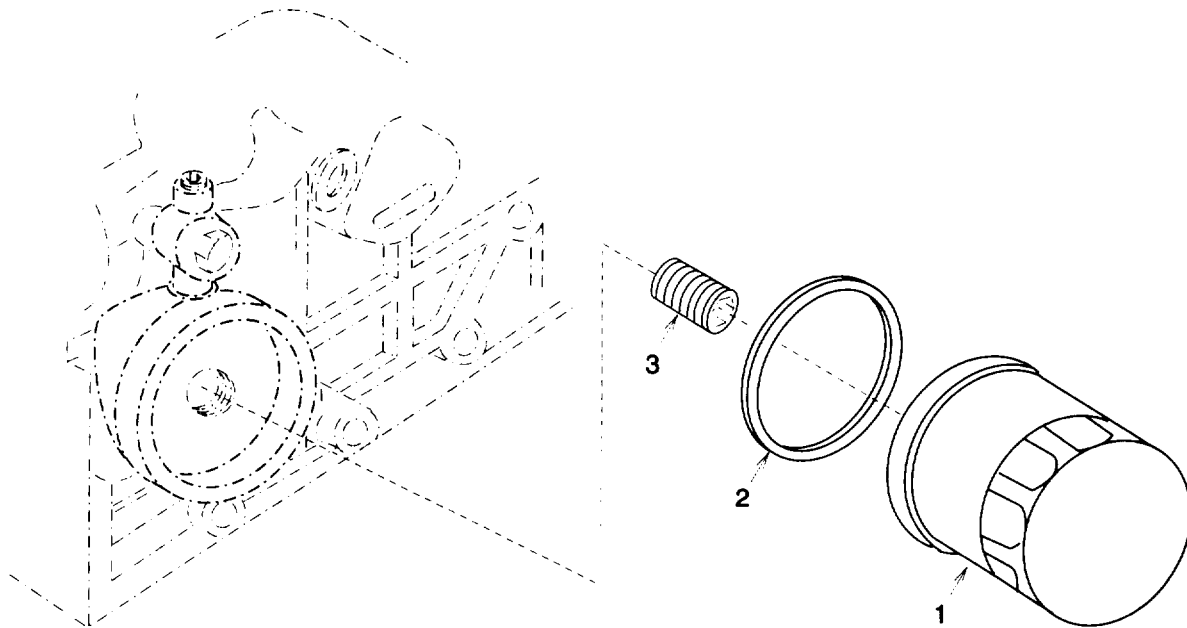
NOTE**FOLLOW-ON MAINTENANCE:**

Close left side door.

Connect battery (para 4-35) and put unit back into service.

4-50. AIR CLEANER REPLACEMENT.

This task covers:**a. Removal****b. Installation**

INITIAL SETUPMaterials/Parts:

Gasket (2)
11, Appendix G
Lock Washers (2)
12, Appendix G

General Safety Instructions:**WARNING**

Exposed rotating parts are used in the refrigeration unit. Personal injury can result if battery is connected.

Equipment Conditions:

Refrigeration unit shut down (para 2-7) and battery disconnected (para 4-35).
Front door open.

a. Removal.

- (1) Loosen clamp (1).
- (2) Remove air cleaner (2) and clamp (1). Discard air cleaner.
- (3) Loosen clamp (3) and disconnect hose (4).
- (4) If air inlet elbow (5) is damaged, remove two nuts (6), flat washers (7), air inlet elbow, gasket (8), adapter (9), and gasket (10).
- (5) If stud (11) is damaged, remove it.
- (6) If air cleaner bracket (12) is damaged, remove two bolts (13), lock washers (14), flat washers (15), and air cleaner bracket. Discard lock washers.

b. Installation.

- (1) If removed, install air cleaner bracket (12), two flat washers (15), new lock washer (14), and bolts (13).
- (2) If stud (11) was removed, install it.
- (3) If air inlet elbow (5) was removed, install new gasket (10), adapter (9), new gasket (8), air inlet elbow, two flat washers (7), and nuts (6).
- (4) Slip clamp (3) over hose (4). Install hose and tighten clamp.

4-50. AIR CLEANER REPLACEMENT. - Continued

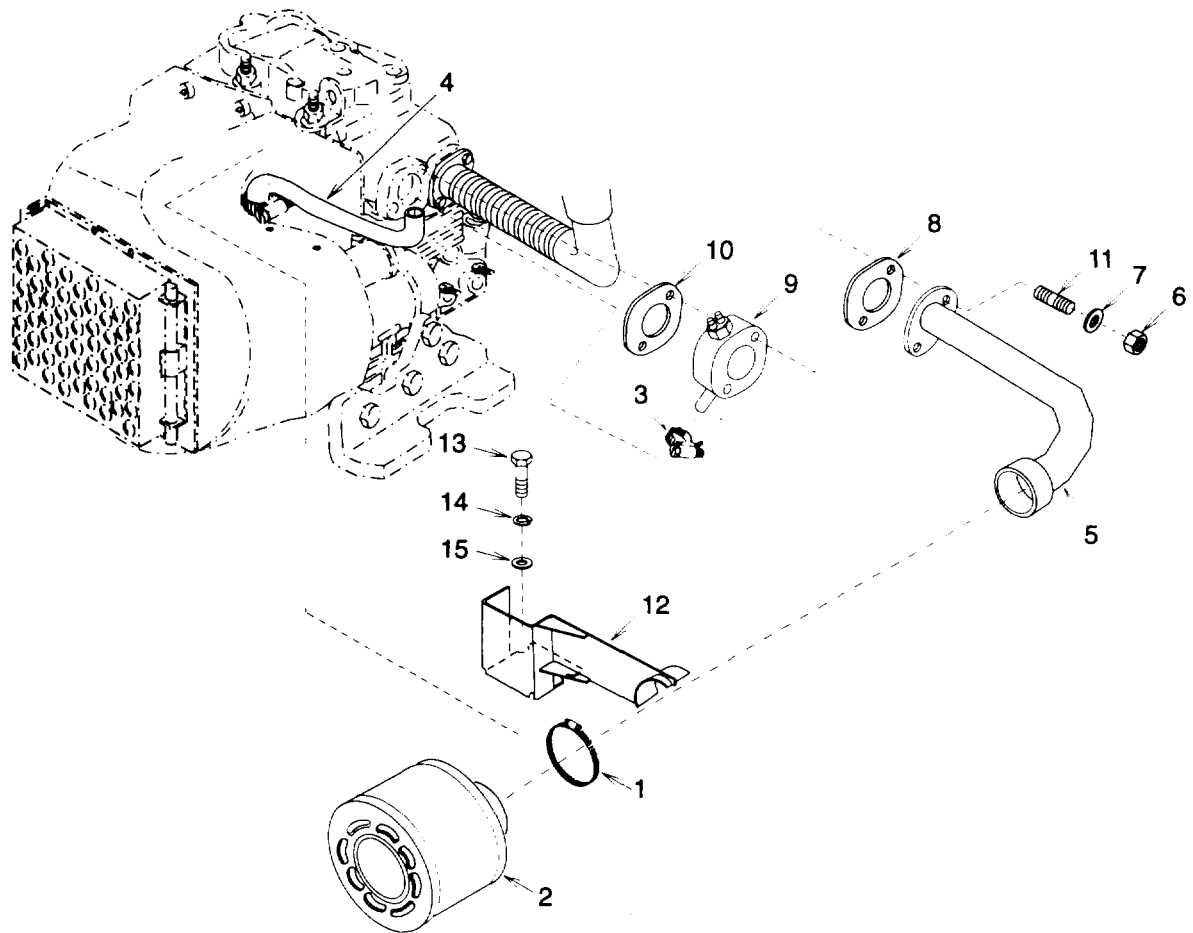

Figure 4-44. Air Cleaner

CAUTION

Never install a used air cleaner onto the adapter. Damage to engine can result if air cleaner is clogged.

- (5) Slip clamp (1) over air cleaner (2).
- (6) Install air cleaner (2) and tighten clamp (1).

NOTE

FOLLOW-ON MAINTENANCE:

Close front door.
Connect battery (para 4-35) and put unit back into service.

4-51. MUFFLER REPLACEMENT.

This task covers:**a. Removal****b. Installation**

INITIAL SETUPMaterials/Parts:

Lock Washers (2)
2, Appendix G
Lock Washers (4)
2, Appendix G
Gasket
31, Appendix G

Equipment Conditions:

Refrigeration unit shut down (para 2-7) and battery disconnected (para 4-35).
Front door open.
Right side door open.

a. Removal.**NOTE****Hardware is supplied with muffler clamps.**

- (1) Loosen two nuts (1). Remove exhaust tube (2) and clamp (3).
- (2) Remove two nuts (4), lock washers (5), and bolts (6). Discard lock washers.

NOTE**Hardware is supplied with muffler clamps.**

- (3) Loosen two nuts (7). Remove muffler (8) and clamp (9).
- (4) If exhaust adapter (10) is damaged, remove two screws (11), exhaust adapter, and gasket (12). Discard gasket.

NOTE**The following procedure applies to both muffler clamps. Quantities listed are for each clamp.**

- (5) If muffler clamp (13) is damaged, remove two bolts (14), lock washers (15), and clamp. Discard lock washers.

b. Installation.**NOTE****The following procedure applies to both muffler clamps. Quantities listed are for each clamp.**

- (1) If removed, install muffler clamp (13), two new lock washers (15) and bolts (14).

4-51. MUFFLER REPLACEMENT. - Continued

Figure 4-45. Muffler

- (2) If exhaust adapter (10) was removed, install new gasket (12), exhaust adapter and two screws (11).
- (3) Slip muffler clamp (9) onto muffler (8). Install muffler and tighten two nuts (7).
- (4) Install two bolts (6), new lock washers (5) and nuts (4).
- (5) Slip muffler clamp (3) onto exhaust tube (2). Install exhaust tube facing down and tighten two nuts (1).

FOLLOW-ON MAINTENANCE:

Close front door.

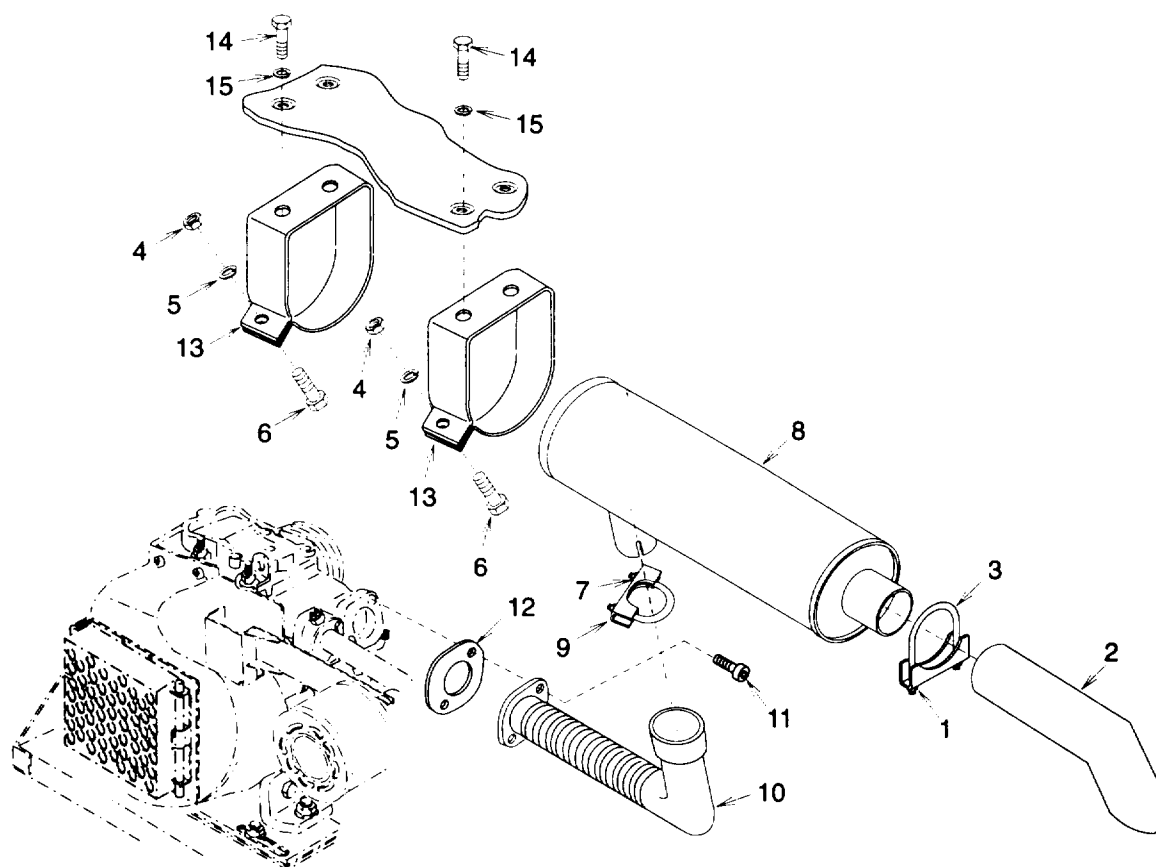
Close right side door.

Connect battery (para 4-35) and put unit back into service.

4-52. ENGINE OIL PRESSURE SWITCH TESTING AND REPLACEMENT.

This task covers:
a. Testing**b. Removal****c. Installation**

INITIAL SETUPMaterials/Parts:

Marker tag
4, Appendix E
Washer
13, Appendix G

Equipment Conditions:

Refrigeration unit shut down (para 2-7) and battery disconnected (para 4-35).
Front door open.

a. Testing. (See Figure 1-4.)

- (1) Pull cap (1) back to expose engine oil pressure switch (2) connector. Tag and disconnect wire lead (3).
- (2) Using multimeter set to measure continuity, check engine oil pressure switch (2) continuity between connector and base. Continuity should be indicated. If no continuity was indicated, replace engine oil pressure switch.
- (3) If no failure was indicated, connect wire lead (3) using tag and wiring diagram (fig. 1-4). Remove tag.
- (4) Push cap (1) over engine oil pressure switch (2) connector.

b. Removal.

- (1) Pull cap (1) back to expose engine oil pressure switch (2) connector. Tag and disconnect wire lead (3).
- (2) Remove engine oil pressure switch (2) and washer (4). Discard washer.

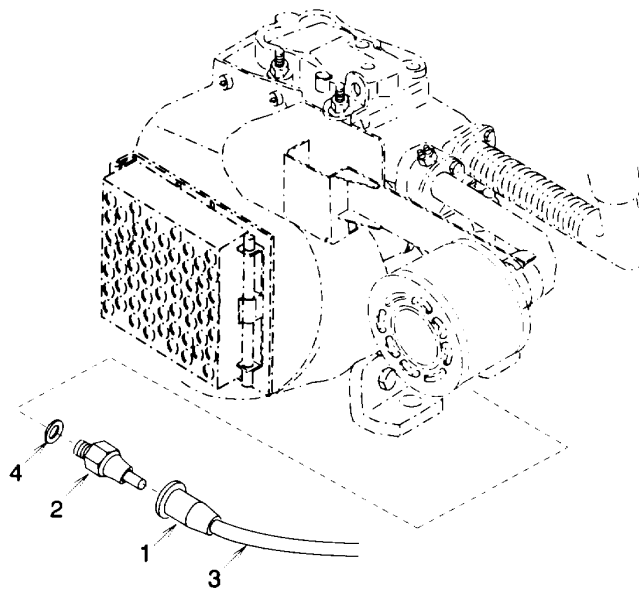
**Figure 4-46. Engine Oil Pressure Switch**

4-52. ENGINE OIL PRESSURE SWITCH TESTING AND REPLACEMENT - Continued**c. Installation.**

- (1) Install new washer (4) and engine oil pressure switch (2).
- (2) Connect wire lead (3) using tag and wiring diagram (fig. 1-4). Remove tag.
- (3) Push cap (1) over engine oil pressure switch (2) connector.

NOTE**FOLLOW-ON MAINTENANCE:**

Close front door.

Connect battery (para 4-35) and put unit back into service.

4-53. ENGINE TEMPERATURE SWITCH TESTING AND REPLACEMENT.**This task covers:****a. Testing****b. Removal****c. Installation****INITIAL SETUP**Materials/Parts:

Marker tag
4, Appendix E
Washer
13, Appendix G

Equipment Conditions:

Refrigeration unit shut down (para 2-7) and battery
disconnected (para 4-35).
Left side door open.

a. Testing. (See Figure 1-4.)

- (1) Tag and disconnect wire lead (1).
- (2) Using multimeter set to measure continuity, check engine temperature switch (2) continuity between connector and base. Continuity should not be indicated. If continuity was indicated, replace engine temperature switch.

(3) If no failure was indicated, connect wire lead (1) using tag and wiring diagram (fig. 1-4). Remove tag.

b. Removal.

- (1) Tag and disconnect wire lead (1).
- (2) Remove engine temperature switch (2) and washer (3). Discard washer.

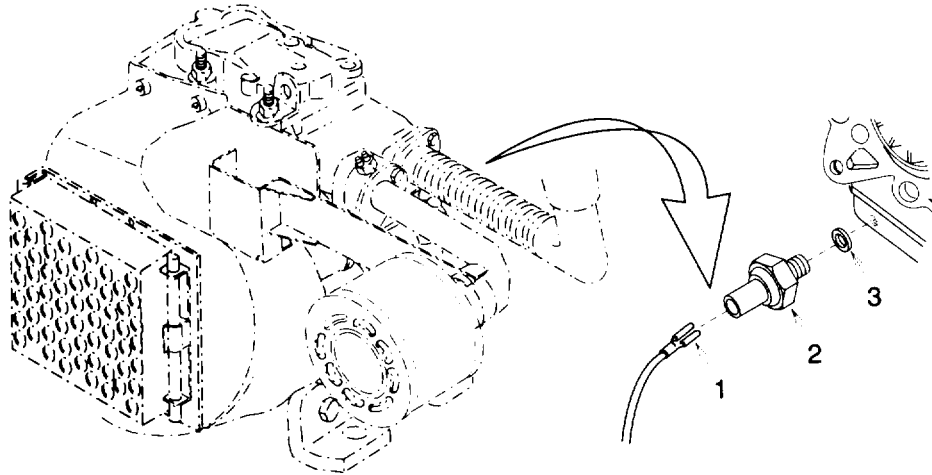

Figure 4-47. Engine Temperature Switch

c. Installation.

- (1) Install new washer (3) and engine temperature switch (2).
- (2) Connect wire lead (1) using tag and wiring diagram (fig. 1-4). Remove tag.

NOTE

FOLLOW-ON MAINTENANCE:

Close left side door.

Connect battery (para 4-35) and put unit back into service.

4-54. FUEL SOLENOID TESTING AND REPLACEMENT.**This task covers:****a. Testing****b. Removal****c. Installation****INITIAL SETUP**Materials/Parts:

Marker tags (3)
 4, Appendix E
 Self Locking Nuts (2) (Fuel Solenoid)
 7, Appendix G
 Self Locking Nut (Lever)
 7, Appendix G

Equipment Conditions:

Refrigeration unit shut down (para 2-7) and battery disconnected (para 4-35).
 Left side door open.

a. Testing.

- (1) Tag and disconnect wire lead connectors (1).
- (2) Remove self locking nut (2), and lever (3). Discard self locking nut.
- (3) Move plunger (4) in and out and check for smooth movement. If movement is stiff or binding, replace fuel solenoid (5).
- (4) Using multimeter set to measure resistance, check fuel solenoid (5) resistance between red and black leads. Resistance of between 10 and 15 ohms should be indicated. If resistance was out of this range, replace fuel solenoid.

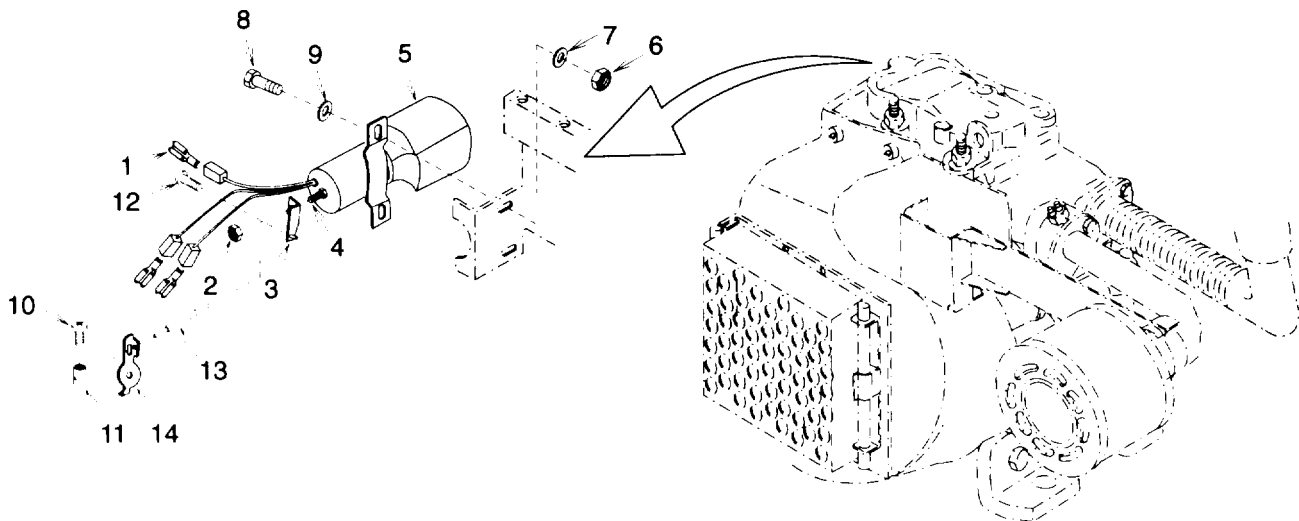
**Figure 4-48 Fuel Solenoid**

- (5) Using multimeter set to measure continuity, check fuel solenoid (5) continuity between white and black leads. Continuity should be indicated. If continuity was not indicated, replace fuel solenoid.
- (6) Using multimeter set to measure continuity, check fuel solenoid (5) continuity between each lead and fuel solenoid case. Continuity should not be indicated. If continuity was indicated, replace fuel solenoid.
- (7) If no failure was indicated, connect wire lead connectors (1) using tags and wiring diagram (fig. 1-4). Remove tags.
- (8) Install lever (3), and new self locking nut (2).

b. Removal.

- (1) Tag and disconnect wire lead connectors (1).
- (2) Remove self locking nut (2), and lever (3). Discard self locking nut.
- (3) Remove two self locking nuts (6), flat washers (7), bolts (8), flat washers (9), and fuel solenoid (5). Discard self locking nuts.
- (4) If linkage assembly is damaged, loosen screw (10) and remove wire stop tube (11). Loosen screw (12) then remove cable (13) and lever (3).

c. Installation.

- (1) If linkage assembly was removed, install cable (13) through lever (14) and into lever (3). Tighten screw (12). Install wire stop tube (11) and tighten screw (10).
- (2) Install fuel solenoid (5), two flat washers (9), bolts (8), flat washers (7), and new self locking nuts (6).
- (3) Install lever (3) and new self locking nut (2).

NOTE

Shut down lever must be in the fully counterclockwise position when the fuel solenoid is relaxed to properly shut down the engine.

- (4) Shut down lever (14) should be fully counterclockwise, cable (13) should not have any slack in it, and fuel solenoid (5) plunger should not be pulled out. If the cable needs to be adjusted, loosen screw(s) (10) or (12) as necessary and adjust cable. Tighten screw(s) when adjustment is complete.
- (5) Using tags and wiring diagram (fig. 1-4), connect wire lead connectors (1). Remove tags.

NOTE

**FOLLOW-ON MAINTENANCE:
Close left side door.
Connect battery (para 4-35) and put unit back into service.**

4-55. STARTING MOTOR REPLACEMENT.

 This task covers:

a. Removal

b. Installation

INITIAL SETUPMaterials/Parts:

Marker tags (3)
4, Appendix E

Equipment Conditions:

Refrigeration unit shut down (para 2-7) and battery disconnected (para 4-35).
Front door open.
Remove air cleaner (para 4-50).

a. Removal.

- (1) Remove two screws (1), flat washers (2), and starting motor (3).

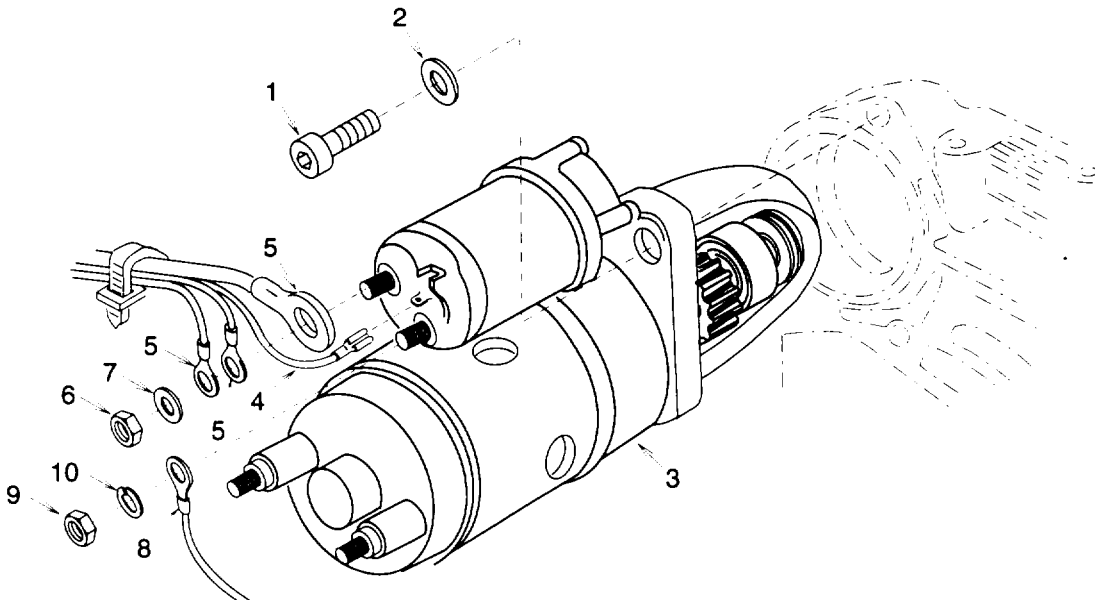

Figure 4-49. Starting Motor

- (2) Tag and disconnect wire lead (4).
(3) Tag wire leads (5). Remove nut (6), flat washer (7), and wire leads.

NOTE

Terminal hardware is supplied with starting motor.

- (4) Tag wire lead (8). Remove nut (9), lock washer (10), and wire lead.

b. Installation.

NOTE

Terminal hardware is supplied with starting motor.

- (1) Using tag and wiring diagram (fig. 1-4), install wire lead (8), lock washer (10), and nut (9). Remove tag.
- (2) Using tags and wiring diagram (fig. 1-4), install wire leads (5), flat washer (7), and nut (6). Remove tags.
- (3) Using tag and wiring diagram (fig. 1-4), connect wire lead (4). Remove tag.
- (4) Install starting motor (3), two flat washers (2), and screws (1).

NOTE

FOLLOW-ON MAINTENANCE:

Install air cleaner (para 4-50).

Close front door.

Connect battery (para 4-35) and put unit back into service.

4-56. FUEL FILTER REPLACEMENT.

This task covers:

a. Removal**b. Installation****INITIAL SETUP**Materials/Parts:

Lock Washer (2)
 12, Appendix G
 Wiping Rags
 9, Appendix E
 Washers (4)
 14, Appendix G

Equipment Conditions:

Refrigeration unit shut down (para 2-7) and battery disconnected (para 4-35).
 Left side door open.

a. Removal.**WARNING**

- **Splashes and spills of fuel can cause eye injury and skin irritation. Wear face shield and approved gloves when handling fuel.**
- **Immediately remove any articles of clothing or shoes that have become soaked with fuel. Stay in an area free from ignition sources until clothing has been removed.**

- (1) Place drain pan under fuel filter element (1) and remove fuel filter element, large seal (2), and small seal (3). Drain filter element into drain pan then discard filter element and seals. Contact your local environmental officer for guidance on how to properly dispose of used fuel in accordance with local regulations.
- (2) Check condition of union (4) and remove if damaged.
- (3) If eye (5) is damaged, remove it.
 - (a) Loosen clamp (6) and remove hose (7).
 - (b) Remove union (8), washer (9), eye (5), and washer (10). Discard washers.
- (4) If fuel filter cover (11) is damaged, remove two unions (8), washers (9), eyes (5), washers (10), two nuts (12), bolts (13), and fuel filter cover. Discard washers.
- (5) If bracket (14) is damaged, remove fuel solenoid (para 4-54). Remove two bolts (15), lock washers (16), flat washers (17), and bracket. Discard lock washers.

b. Installation.

- (1) If bracket (14) was removed, install bracket, two flat washers (17), new lock washers (16), and bolts (15). Install fuel solenoid (para 4-54).

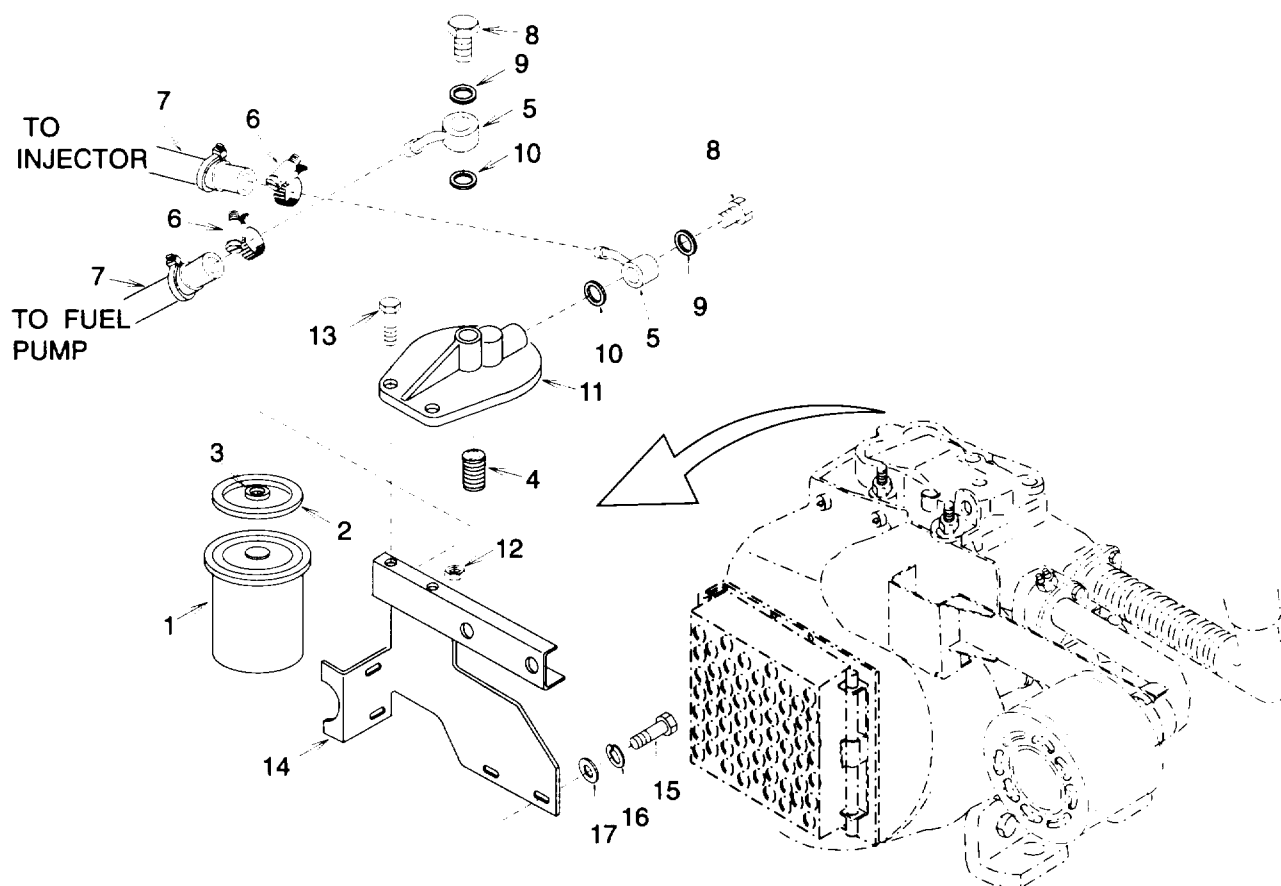

Figure 4-50. Fuel Filter

- (2) If fuel filter cover (11) was removed, install fuel filter cover, two bolts (13), nuts (12), two new washers (10), eyes (5), new washers (9), and unions (8).
- (3) If eye (5) was removed, install it.
 - (a) Install new washer (10), eye (5), new washer (9), and union (8).
 - (b) Install hose (7), and tighten clamp (6).
- (4) If union (4) was removed, install it.
- (5) Install new small seal (3), new large seal (2), and new fuel filter element (1).

NOTE

FOLLOW-ON MAINTENANCE:
Close left side door.
Connect battery (para 4-35) and put unit back into service.

4-57. VOLTAGE REGULATOR REPLACEMENT.**This task covers:****a. Removal****b. Installation****INITIAL SETUP****Materials/Parts:**

Lock Washers (2)
2, Appendix G

Equipment Conditions:

Refrigeration unit shut down (para 2-7) and battery
disconnected (para 4-35).
Left side door open.

a. Removal.

- (1) Disconnect connector (1) from voltage regulator (2).

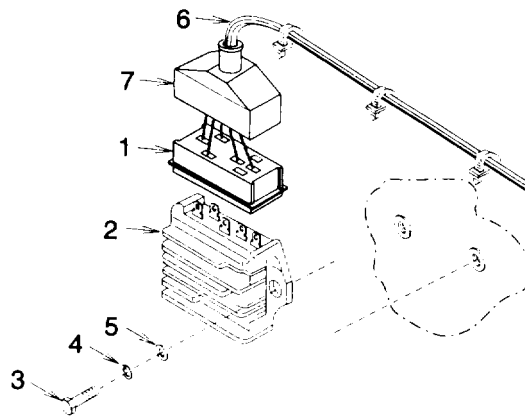
**Figure 4-51. Voltage Regulator**

- (2) Remove two bolts (3), lock washers (4), flat washers (5), and voltage regulator (2). Discard lock washers.

b. Installation.

- (1) Install voltage regulator (2), two flat washer (5), new lock washers (4), and bolts (3).
- (2) If connection (1) or any wire leads (6) are damaged, pull cap (7) back and replace or repair as necessary per paragraph 4-19.
- (3) If cap (7) was pulled back, slip back over connection (1) then plug connection onto voltage regulator (2).

NOTE**FOLLOW-ON MAINTENANCE:**

Close right side door.

Connect battery (para 4-35) and put unit back into service.

4-58. ALTERNATOR TESTING.

This task covers: Testing

INITIAL SETUP

Equipment Conditions:

Refrigeration unit shut down (para 2-7) and battery disconnected (para 4-35).
Right side door open.

Testing.

- (1) Unplug connection (1) from voltage regulator (2).
- (2) Using multimeter set to measure resistance, check continuity between terminals G to G (3) on connection (1). Continuity should be indicated. If no continuity was indicated, notify direct support maintenance.
- (3) Using multimeter set to measure resistance, check continuity between each terminal G (3) to engine frame. Continuity should not be indicated. If continuity was indicated, notify direct support maintenance.
- (4) If no failure was indicated, install connection (1) onto voltage regulator (2).

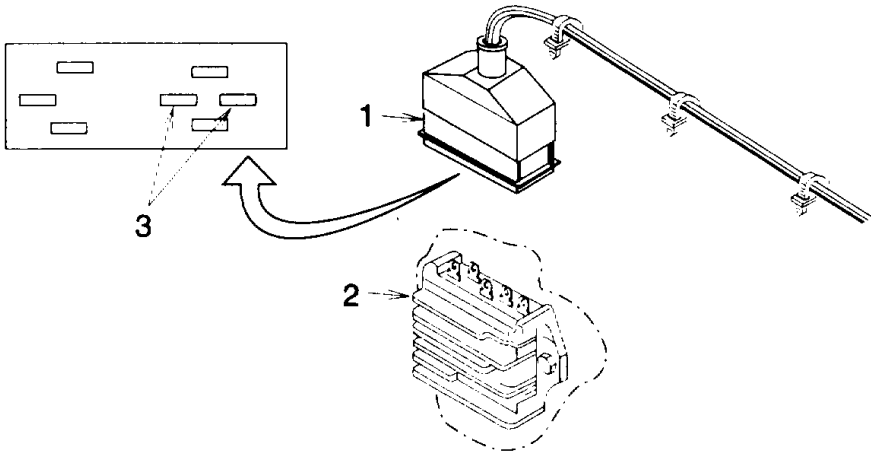

Figure 4-52. Alternator Test Point

NOTE

FOLLOW-ON MAINTENANCE:
Close right side door.
Connect battery (para 4-35) and put unit back into service.

4-59. GLOW PLUG TESTING AND REPLACEMENT.

This task covers: a. Testing b. Removal c. Installation

INITIAL SETUPMaterials/ Parts:

Marker tag
4, Appendix E

Equipment Conditions:

Refrigeration unit shut down (para 2-7) and battery disconnected (para 4-35).
Front door open.

a. Testing.

- (1) Tag wire lead (1).

NOTE

Terminal hardware is supplied with glow plug.

- (2) Remove nut (2) and wire lead (1).
- (3) Using multimeter set to measure continuity, check glow plug (3) continuity between terminal and base of glow plug. Continuity should be indicated. If no continuity was indicated, replace glow plug.
- (4) If no failure was indicated, install wire lead (1) and nut (2) per tag and wiring diagram (fig. 1-4). Remove tag.

b. Removal.

- (1) Tag wire lead (1).

NOTE

Terminal hardware is supplied with glow plug.

- (2) Remove nut (2) and wire lead (1).
- (3) Remove glow plug (3).

c. Installation.

- (1) Install glow plug (3).
- (2) Install wire lead (1) and nut (2) per tag and wiring diagram (fig. 1-4). Remove tag.

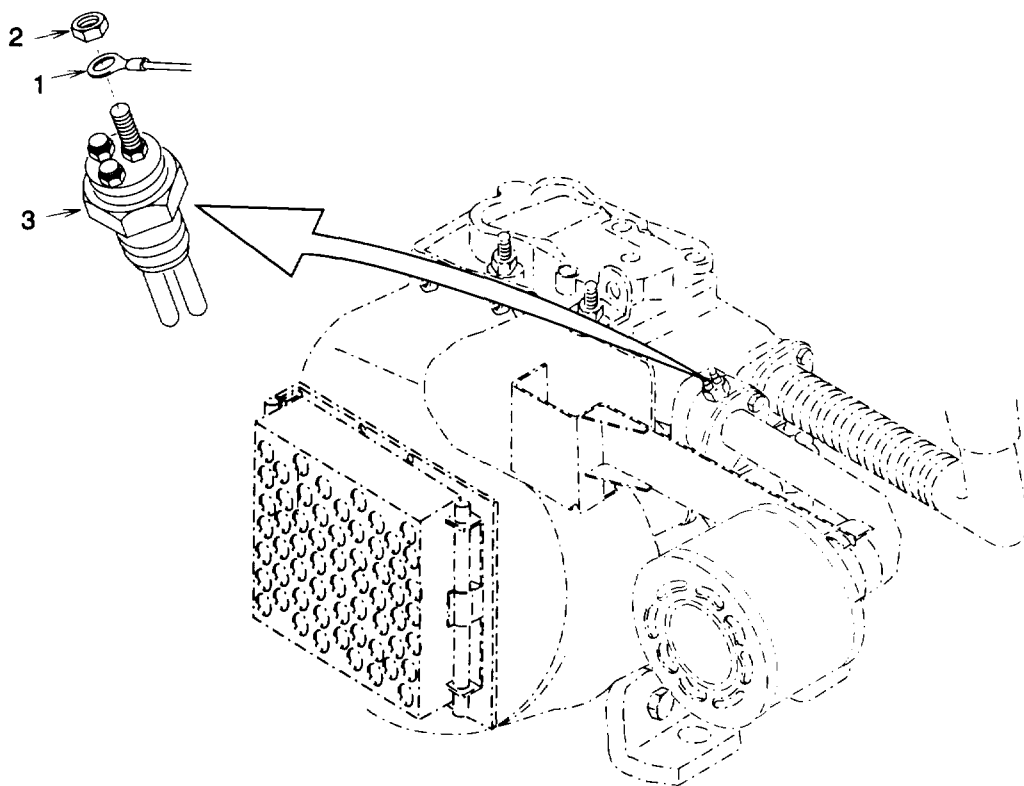

Figure 4-53. Glow Plug

NOTE

FOLLOW-ON MAINTENANCE:
Close front side door.
Connect battery (para 4-35) and put unit back into service.

4-60. ENGINE DRAIN HOSE REPLACEMENT.

This task covers: a. Removal b. Installation

INITIAL SETUPMaterials/Parts:

Wiping Rags
9, Appendix E

Equipment Conditions:

Refrigeration unit shut down (para 2-7) and battery disconnected (para 4-35).
Left side door open.
Front door open.

a. Removal.(1) Drain oil.

- (a) Remove oil fill plug (1).
- (b) Place drain pan under oil drain hose (2).
- (c) Remove oil drain plug (3) and allow oil to drain completely.
- (d) Contact your local environmental officer for guidance on how to properly dispose of used oil in accordance with local regulations.

NOTE

Hose may contain oil. Appropriate actions should be taken to contain spills.

- (2) Loosen clamp (4) and remove hose end fitting (5).
- (3) Loosen clamp (6) and remove hose (2).
- (4) Remove hose fitting (7).

b. Installation.

- (1) Install hose fitting (7).
- (2) Slide clamp (6) over hose (2) end and install hose onto fitting (7). Tighten clamp.
- (3) Slide clamp (4) over hose(2) end and install hose end fitting (5) into hose. Tighten clamp.
- (4) Install oil drain plug (3).

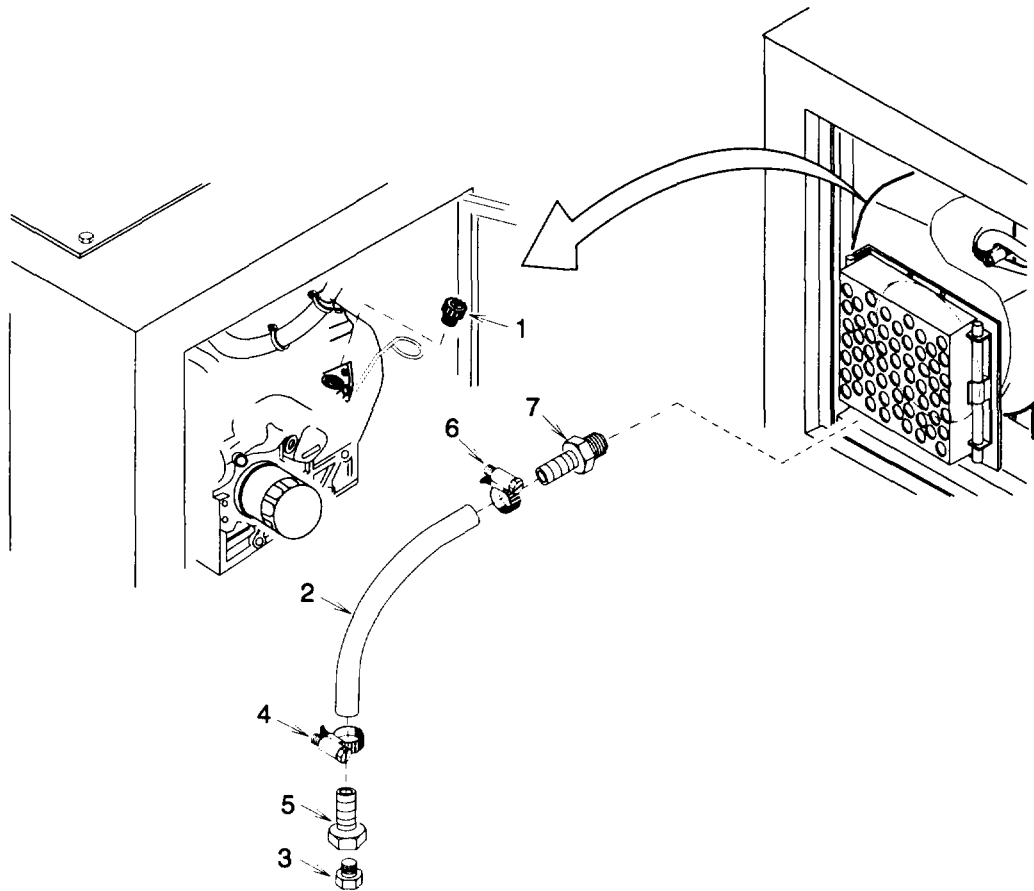

Figure 4-54. Engine Drain Hose

- (5) Fill engine with oil.
- (a) Fill engine with appropriate grade and quantity of oil (para 4-7).
 - (b) Install oil fill plug (1).

NOTE

FOLLOW-ON MAINTENANCE:

Close left side door.

Close front door.

Connect battery (para 4-35) and put unit back into service.

4-61. ENGINE REPAIR AND REPLACEMENT.

 This task covers: a. Removal b. Installation

INITIAL SETUPMaterials/Parts:

Lock Washers (2)
 12, Appendix G
 Self Locking Nuts (4)
 10, Appendix G
 Rivets (4)
 33, Appendix G
 Wiping Rags
 9, Appendix E
 Marker tags (2)
 4, Appendix E

Equipment Conditions:

Starting motor wire leads disconnected (para 4-55).
 Engine oil pressure switch wire lead disconnected (para 4-52).
 Engine temperature switch wire lead disconnected (para 4-53).
 Fuel solenoid removed (para 4-54).
 Engine drain hose removed (para 4-60).
 Fuel supply hoses disconnected from fuel pump (para 4-62).
 Fuel return hose disconnected at hose connector (para 4-63).
 Fuel filter and bracket removed (para 4-56).
 V-belts removed from engine pulley (para 4-38).

Equipment Conditions:

Refrigeration unit shut down (para 2-7).
 Front door open.
 Left side door open.
 Battery and battery frame removed (para 4-35).
 Air cleaner and adapter removed (para 4-50).
 Muffler and exhaust adapter removed (para 4-51).

a. Removal.

- (1) Tag and disconnect wire leads (1) by removing two wire splices (2).
- (2) Remove four self locking nuts (3), flat washers (4), and ground strap (5). Discard self locking nuts.
- (3) If ground strap (5) is damaged, remove nut (6), lock washer (7), flat washer (8), bolt (9) and ground strap. Discard lock washer.
- (4) Remove two bolts (10), lock washers (11), and adjustment channel bracket (12). Back out swivel bolt (13). Discard lock washers.

WARNING

Engine weight exceeds 95 lb. (43 kg). Use appropriate lifting device to avoid personal injury.

- (5) Using an appropriate lifting device, carefully remove engine (14).
- (6) Drill out four rivets (15) using drill bit slightly smaller than rivet diameter. Remove four flat washers (16) and engine guard (17).

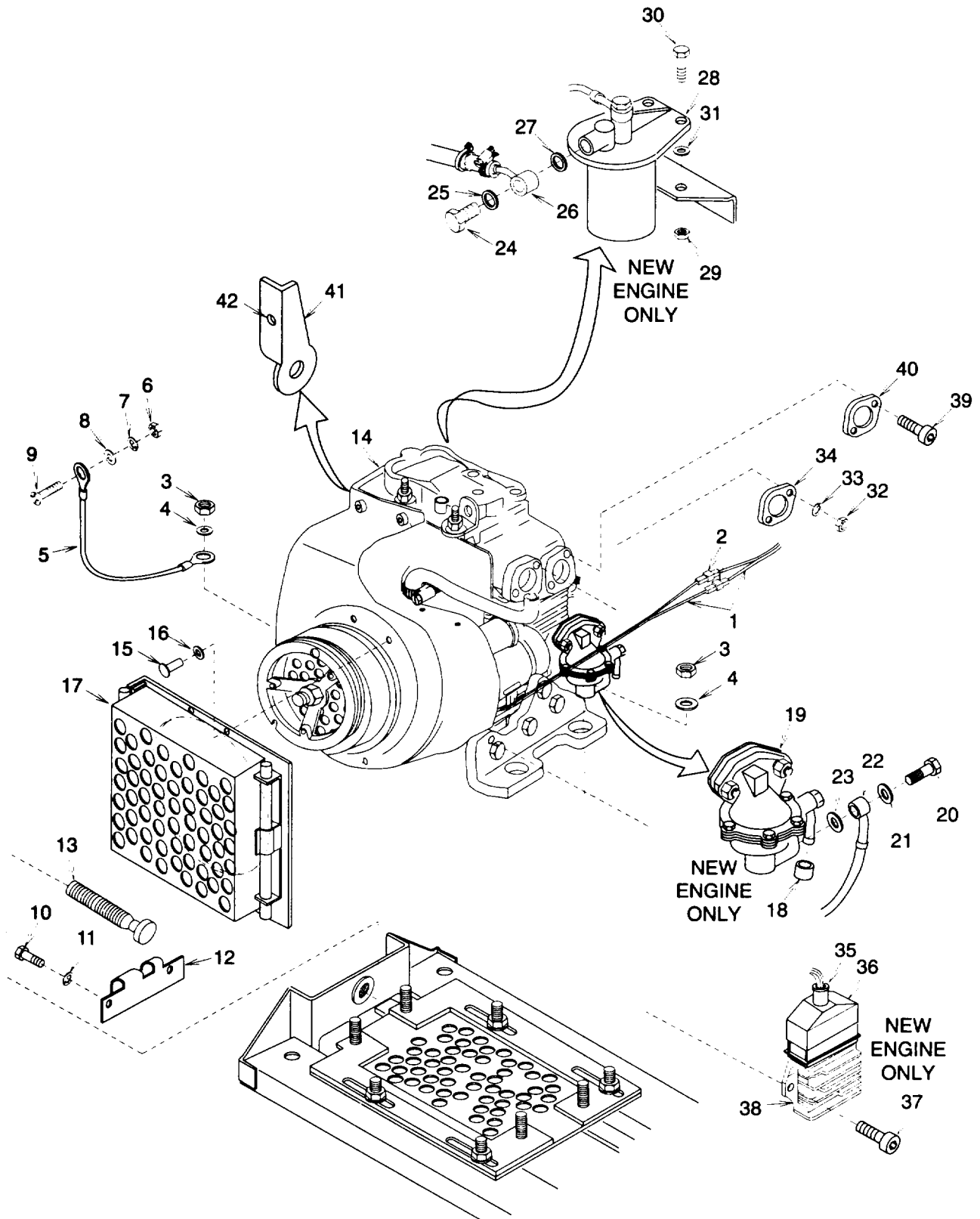

Figure 4-55. Engine.

4-61. ENGINE REPAIR AND REPLACEMENT. - Continuedb. Installation.

- (1) Prepare New Engine. Certain components shipped with new engine must be removed prior to installation.

NOTE

Hoses may contain fuel. Appropriate actions should be taken to contain spills.

- (a) Remove and discard protective cap (18) from fuel pump (19).
- (b) Remove union (20), washer (21), eye (22), and washer (23) from fuel pump (19).
- (c) Remove union (24), washer (25), eye (26), and washer (27) from fuel filter assembly (28).
- (d) Place drain pan under fuel filter assembly (28). Remove nut (29), bolt (30), and spacer (31). Invert fuel filter assembly to drain fuel into drain pan. Retain fuel filter assembly for use as spare part.
- (e) Contact your local environmental officer for guidance on how to properly dispose of used fuel in accordance with local regulations.
- (f) Remove two nuts (32), lock washers (33), and gasket (34). Retain gasket for use during installation.
- (g) Cut wire lead (35) just above cap (36).
- (h) Remove two screws (37) and voltage regulator (38). Retain voltage regulator for use as spare part.
- (i) Remove two screws (39) and gasket (40). Retain gasket for use during installation.
- (j) Install engine guard (17), two flat washers (16), and new rivets (15).
- (k) Drill a 0.15 in. (0.38 cm) hole in engine stop lever (41) at existing hole location (42).

WARNING

Engine weight exceeds 95 lb. (43 kg). Use appropriate lifting device to avoid personal injury.

- (2) Using an appropriate lifting device, carefully install engine (14).
- (3) Install adjustment channel bracket (12) onto swivel bolt (13). Turn in swivel bolt and secure adjustment channel bracket with two new lock washers (11) and bolts (10).

- (4) Install ground strap (5), four flat washers (4), and new self locking nuts (3).
- (5) If removed, install ground strap (5), bolt (9), flat washer (8), new lock washer (7), and nut (6).
- (6) Using tags and wiring diagram (fig. 1-4), connect wire leads (1). Remove tags.

NOTE

FOLLOW-ON MAINTENANCE:

- Install and adjust engine V-belts (para 4-38).**
- Connect fuel return hose to hose connector (para 4-63).**
- Connect fuel supply hoses to fuel pump (para 4-62).**
- Install fuel filter and bracket (para 4-56).**
- Connect injection pump to fuel filter hose assembly onto fuel filter (para 4-62).**
- Install engine drain hose (para 4-60).**
- Install fuel solenoid (para 4-54).**
- Connect engine temperature switch wire lead (para 4-53).**
- Connect engine oil pressure switch wire lead (para 4-52).**
- Connect starting motor wire leads (para 4-55).**
- Install air cleaner and adapter (para 4-50).**
- Install muffler and exhaust adapter (para 4-51).**
- Fill engine with appropriate lubricating oil (para 4-7).**
- Install battery frame and battery (para 4-35).**
- Install top access panel (para 4-13).**
- Close left side door.**
- Close front door.**
- Put unit back into service.**

4-62. FUEL SUPPLY HOSES/FUEL PIPE REPAIR AND REPLACEMENT.

This task covers: a. Removal b. Installation

INITIAL SETUP

Materials/Parts:

- Tie Down Straps (As Required)
5, Appendix E
- Wiping Rags
9, Appendix E
- Washers (4)
14, Appendix G
- Washers (4)
16, Appendix G
- Washer
18, Appendix G
- Washer
19, Appendix G
- Washers (2)
20, Appendix G
- Washers (2)
21, Appendix G

Materials/Parts:

- Gasket
17, Appendix G
- Nut
24, Appendix G
- Ferrule Tube
25, Appendix G
- Connector
26, Appendix G

Equipment Conditions:

Refrigeration unit shut down (para 2-7) and battery disconnected (para 4-35).
Both side doors open.

NOTE

Hose repair is limited to replacement of damaged components or assemblies.

- a. Removal.

WARNING

Hoses and fuel pipe may contain fuel. Injury to personnel can occur when removing. Appropriate actions should be taken to contain spills.

- (1) Fuel tank to in-line fuel filter hose assembly.
 - (a) Cut tie down straps (1) and remove loom (2).
 - (b) Note in-line filter (3) flow direction then loosen two clamps (4) and remove hose (5).

NOTE

Connector, nut, and tube ferrule are not re-usable. Do not remove unless any of these parts or fuel inlet elbow must be replaced.

- (c) If connector (6) or fuel inlet elbow (7) is damaged, loosen nut (8) then remove connector, tube ferrule (9), and if damaged, inlet elbow. Discard connector, nut, and tube ferrule.

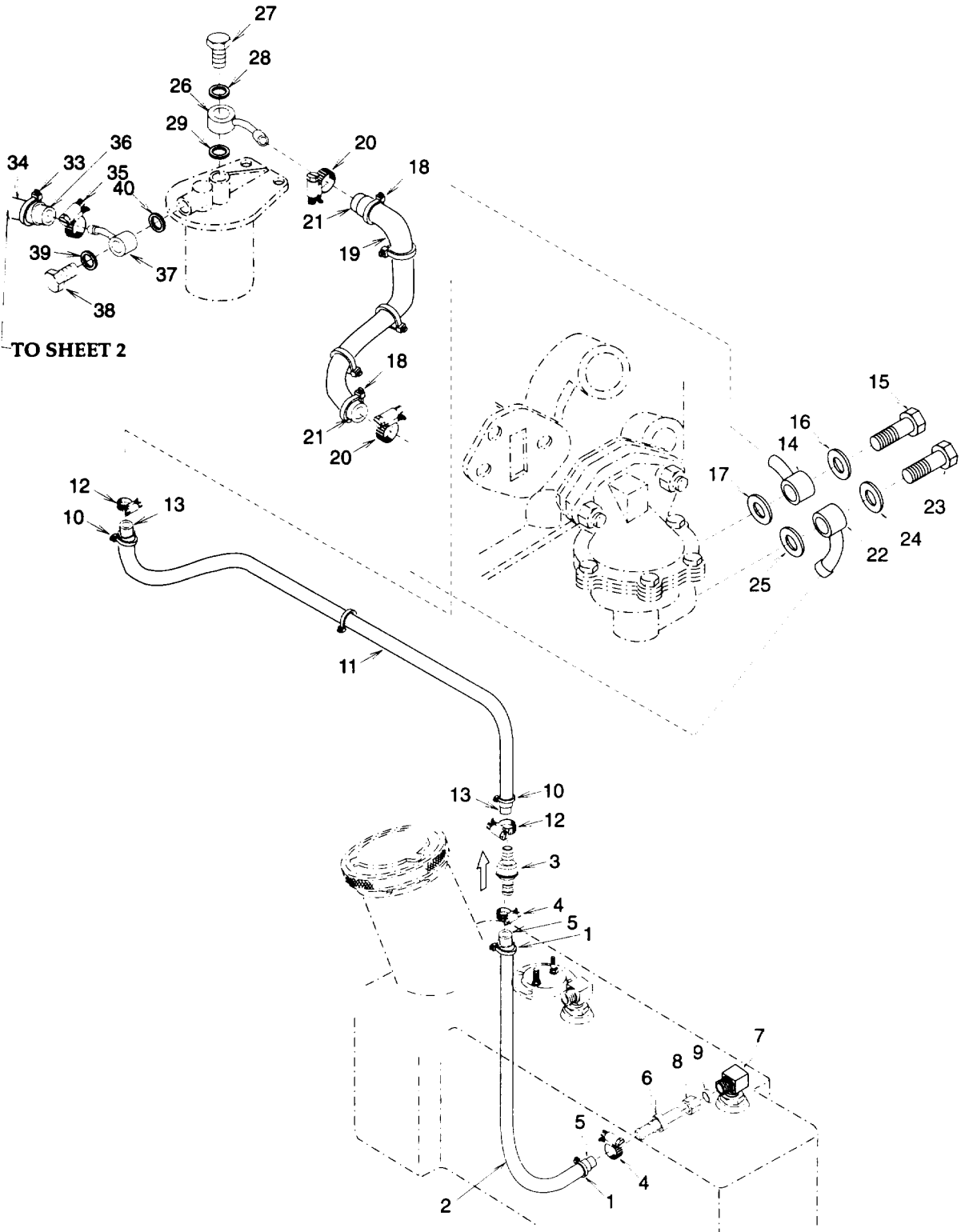

Figure 4-56. Fuel Supply Hoses (Sheet 1 of 2)

4-62. FUEL SUPPLY HOSES/FUEL PIPE REPAIR AND REPLACEMENT. - Continued

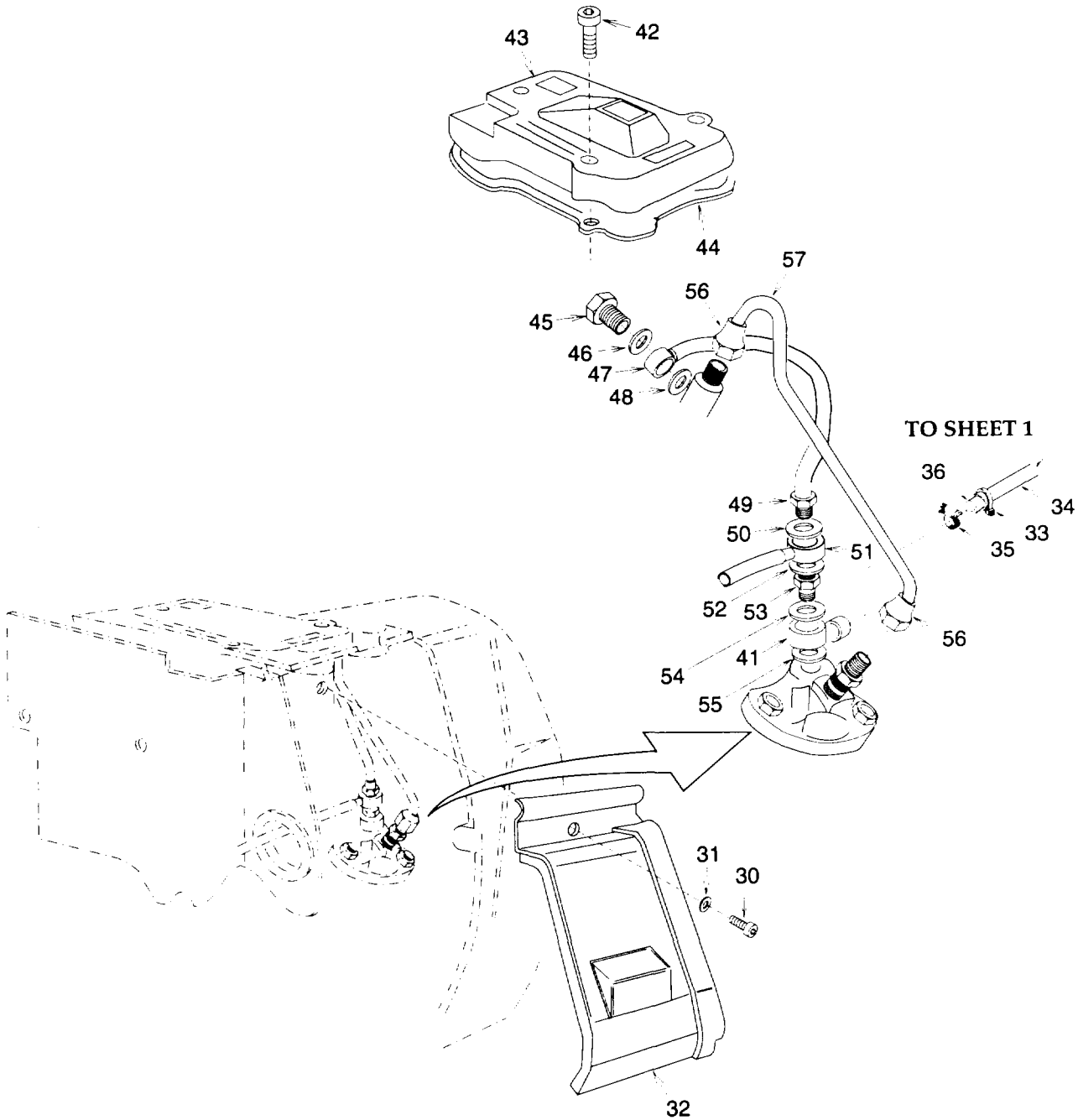

Figure 4-56. Fuel Supply Hoses (Sheet 2 of 2)

- (2) In-line fuel filter to fuel pump hose assembly.
- (a) Cut tie down straps (10) and remove loom (11).
 - (b) Note in-line filter (3) flow direction then loosen two clamps (12) and remove hose (13).
 - (c) If eye (14) is damaged, remove union (15), washer (16), eye, and washer (17). Discard washers.
- (3) Fuel pump to fuel filter hose assembly.
- (a) Cut tie down straps (18) and remove loom (19).
 - (b) Loosen two clamps (20) and remove hose (21).
 - (c) If eye (22) is damaged, remove union (23), washer (24), eye, and washer (25). Discard washers.
 - (d) If eye (26) is damaged, remove union (27), washer (28), eye, and washer (29). Discard washers.
- (4) Fuel filter to injection pump hose assembly.
- (a) Remove screw (30), flat washer (31), and cylinder casing (32).
 - (b) Cut tie down straps (33) and remove loom (34).
 - (c) Loosen two clamps (35) and remove hose (36).
 - (d) If eye (37) is damaged, remove union (38), washer (39), eye, and washer (40). Discard washers.
 - (e) If eye (41) is damaged, remove it.
 - 1 Remove top access panel (para 4-13).
 - 2 Remove three screws (42), cover (43), and gasket (44). Discard gasket.
 - 3 Remove union (45), washer (46), eye (47), and washer (48). Discard washers.
 - 4 Remove union (49), washer (50), eye (51), and washer (52). Discard washers.
 - 5 Remove union (53), washer (54), eye (41), and washer (55). Discard washers.

4-62. FUEL SUPPLY HOSES/FUEL PIPE REPAIR AND REPLACEMENT. - Continued(5) Injection pump to nozzle tube assembly.

- (a) Remove screw (30), flat washer (31), and cylinder casing (32).
- (b) Remove to access panel (para 4-13).
- (c) Remove three screws (42), cover (43), and gasket (44). Discard gasket.

CAUTION

Always use two wrenches when loosening the fuel pipe to prevent turning the nozzle or injection pump fitting.

- (d) Loosen two flare nuts (56) and remove fuel pipe (57).

b. Installation.(1) Injection pump to nozzle tube assembly.**CAUTION**

Always use two wrenches when tightening the fuel pipe to prevent turning the nozzle or injection pump fitting.

- (a) Install fuel pipe (57) and tighten two flare nuts (56).
 - (b) Install new gasket (44), cover (43) and three screws (42).
 - (c) Install cylinder casing (32), flat washer (31), and screw (30).
 - (d) Install top access panel (para 4-13).
- (2) Fuel filter to injection pump hose assembly.
- (a) If eye (41) was removed, install it.
 - 1 Install new washer (55), eye (41), new washer (54), and union (53).
 - 2 Install new washer (52), eye (51), new washer (50), and union (49).
 - 3 Install new washer (48), eye (47), new washer (46), and union (45).
 - (b) If eye (37) was removed, install new washer (40), eye, new washer (39), and union (38).
 - (c) Slide one each clamp (35) over hose (36) ends and install hose. Tighten clamps.
 - (d) Install loom (34) over hose (36) and secure using tie down straps (33) as necessary.
 - (e) Install cylinder casing (32), flat washer (31), and screw (30).

- (3) Fuel pump to fuel filter hose assembly.
 - (a) If eye (22) was removed, install new washer (25), eye, new washer (24), and union (23).
 - (b) If eye (26) was removed, install new washer (29), eye, new washer (28), and union (27).
 - (c) Slide one each clamp (20) over hose (21) ends and install hose. Tighten clamp.
 - (d) Install loom (19) over hose (21) and secure using tie down straps (18) as necessary.
- (4) In-line fuel filter to fuel pump hose assembly.
 - (a) If eye (14) was removed, install new washer (17), eye, new washer (16) and union (15).
 - (b) Be sure to observe in-line filter (3) flow direction noted during removal then slide one each clamp (12) over hose (13) ends and install hose. Tighten clamps.
 - (c) Install loom (11) over hose (13) and secure using tie down straps (10) as necessary.
- (5) Fuel tank to in-line fuel filter hose assembly.
 - (a) If removed, install fuel inlet elbow (7).
 - (b) If removed, install new nut (8) and new tube ferrule (9) onto new connector (6). Install connector into fuel inlet elbow (7) and tighten nut to compress tube ferrule.
 - (c) Be sure to observe in-line filter (3) flow direction noted during removal then slide one each clamp (4) over hose (5) ends and install hose. Tighten clamps.
 - (d) Install loom (2) over hose (5) and secure using tie down straps (1) as necessary.

NOTE

FOLLOW-ON MAINTENANCE:

Close both side doors.

Connect battery (para 4-35) and put unit back into service.

4-63. FUEL RETURN HOSES REPLACEMENT.

 This task covers: a. Removal b. Installation

INITIAL SETUPMaterials/Parts:

Tie Down Straps (As Required)
 5, Appendix E
 Wiping Rags
 9, Appendix E
 Washer
 18, Appendix G
 Washer
 19, Appendix G
 Washers (2)
 20, Appendix G
 Washers (2)
 21, Appendix G
 Clamps (2)
 16, Appendix E

Materials/Parts:

Gasket
 17, Appendix G
 Nut
 24, Appendix G
 Ferrule Tube
 25, Appendix G
 Connector
 26, Appendix G

Equipment Conditions:

Refrigeration unit shut down (para 2-7) and battery disconnected (para 4-35).
 Both side doors open.

NOTE

Hose repair is limited to replacement of damaged components or assemblies.

a. Removal.**WARNING**

Hoses may contain fuel. Injury to personnel can occur when removing. Appropriate actions should be taken to contain spills.

(1) Nozzle to injection pump hose.

- (a) Remove screw (1), flat washer (2) and cylinder casing (3).
- (b) Remove top access panel (para 4-13).
- (c) Remove three screws (4), cover (5), and gasket (6). Discard gasket.
- (d) Remove two clamps (7). Discard clamps.
- (e) Remove hose (8).
- (f) If eye (9) is damaged, remove union (10), washer (11), eye, and washer (12). Discard washers.
- (g) If union (13) is damaged, remove union, washer (14), eye (15), and washer (16). Discard washers.

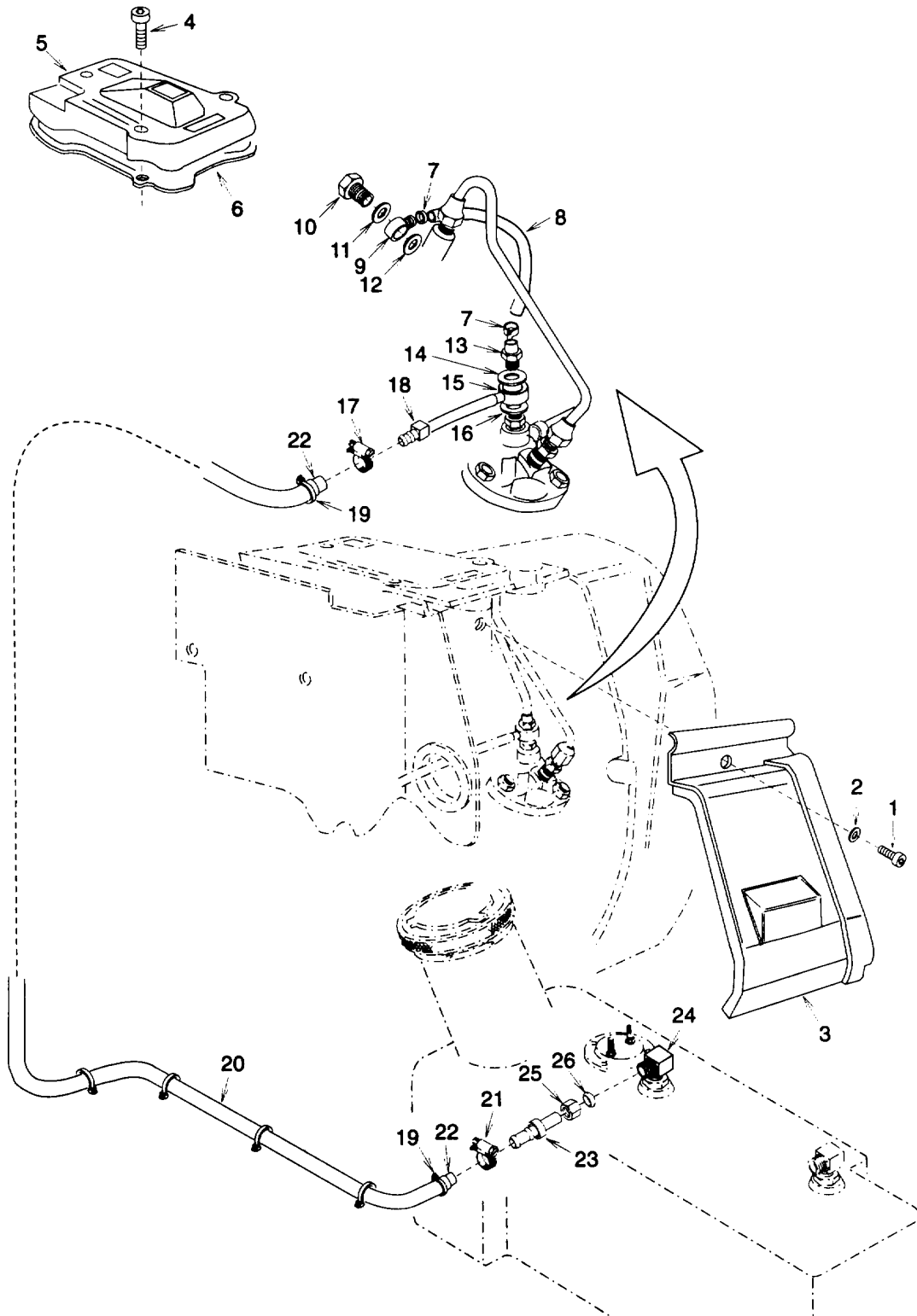

Figure 4-57. Fuel Return Hoses

4-63. FUEL RETURN HOSES REPLACEMENT. - Continued

- (2) Injection pump to connector hose assembly
 - (a) Remove screw (1), flat washer (2) and cylinder casing (3).
 - (b) Remove three screws (4), cover (5), and gasket (6). Discard gasket.
 - (c) Remove union (10), washer (11), eye (9), and washer (12). Discard washers.
 - (d) Remove union (13), washer (14), eye (15), and washer (16). Discard washers.
 - (e) Loosen clamp (17) and remove connector (18).
- (3) Connector to fuel tank hose assembly
 - (a) Cut tie down straps (19) and remove loom (20).
 - (b) Loosen clamps (17) and (21). Remove hose (22).

NOTE

Connector, nut, and tube ferrule are not re-usable. Do not remove unless any of these parts or fuel inlet elbow must be replaced.

- (c) If connector (23) or fuel inlet elbow (24) is damaged, loosen nut (25) then remove connector, tube ferrule (26), and if damaged, inlet elbow. Discard connector, nut, and tube ferrule.

b. Installation.

- (1) Connector to fuel tank hose assembly
 - (a) If removed, install fuel inlet elbow (24).
 - (b) If removed, install new nut (25) and new tube ferrule (26) onto new connector (23). Install connector into fuel inlet elbow (24) and tighten nut to compress tube ferrule.
 - (c) Slide clamps (17) and (21) over hose (22) ends and install hose. Tighten clamps.
 - (d) Install loom (20) over hose (22) and secure using tie down straps (19) as necessary.
- (2) Injection pump to connector hose assembly.
 - (a) Slide clamp (17) over hose (22) end and install connector (18). Tighten clamp.
 - (b) Install new washer (16), eye (15), new washer (14), and union (13).
 - (c) Install new washer (12), eye (9), new washer (11), and union (10).
 - (d) Install new gasket (6), cover (5), and three screws (4).
 - (e) Install cylinder casing (3), flat washer (2) and screw (1).

(3) Nozzle to injection pump hose.

- (a) If union (13) was removed, install new washer (16), eye (15), new washer (14), and union.
- (b) If eye (9) was removed, install new washer (12), eye, new washer (11), and union (10).
- (c) Slide two new clamps (7) over hose (8) ends and install hose. Secure clamps.
- (d) Install new gasket (6), cover (5), and three screws (4).
- (e) Install cylinder casing (3), flat washer (2) and screw (1).
- (f) Install top access panel (para 4-13).

NOTE

FOLLOW-ON MAINTENANCE:

Close both side condenser doors.

Connect battery (para 4-35) and put unit back into service.

4-64. IN-LINE FUEL FILTER REPLACEMENT.

This task covers: a. Removal b. Installation

INITIAL SETUP

Materials/Parts:

Wiping Rags
9, Appendix E

Equipment Conditions:

Refrigeration unit shut down (para 2-7) and battery disconnected (para 4-35).
Right side door open.

WARNING

Hoses may contain fuel. Injury to personnel can occur when removing. Appropriate actions should be taken to contain spills.

NOTE

Note fuel flow direction before removal.

- a. Removal. Loosen two clamps (1) then remove in-line fuel filter (2) and clamps.

4-64. IN-LINE FUEL FILTER REPLACEMENT. - Continued

b. Installation.

- (1) Slide one each clamp (1) over hose (3) ends.
- (2) Install in-line fuel filter (2) with flow direction as note during removal and tighten clamps (1).

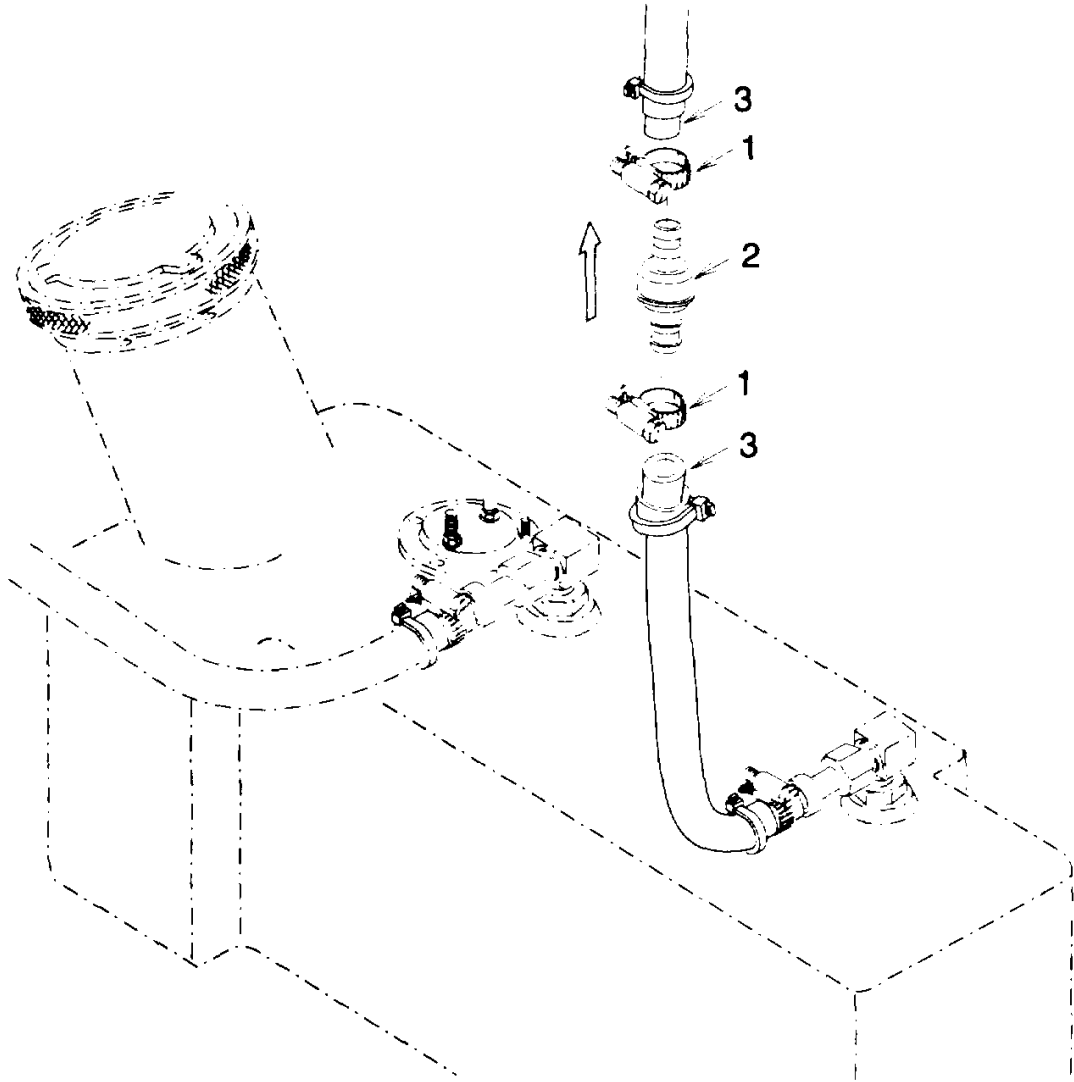

Figure 458. In-line Fuel Filter

NOTE

FOLLOW-ON MAINTENANCE:

Close Right side door.
Connect battery (para 4-35) and put unit back into service.

4-65. FUEL GAGE REPLACEMENT.

This task covers:

a. Removal

b. Installation

INITIAL SETUP

Materials / Parts:

Marker tags (3)
4, Appendix E

Equipment Conditions:

Refrigeration unit shut down (para 2-7) and battery
disconnected (para 4-35).
Right side door open.

a. Removal.

- (1) Tag wire leads (1).

NOTE

Terminal hardware is supplied with fuel gage.

- (2) Remove three nuts (2), and wire leads (1).
- (3) Remove three nuts (3), retainer (4), and fuel gage (5).

b. Installation.

CAUTION

Overtightening retainer nuts will cause the retainer to deform and possibly crack or break.

- (1) Install fuel gage (5), retainer (4), and three nuts (3) being careful not to over tighten.
- (2) Using tags and wiring diagram (fig. 1-4), install wire leads (1) and secure using three nuts (2). Remove tags.

4-65. FUEL GAGE REPLACEMENT. - Continued

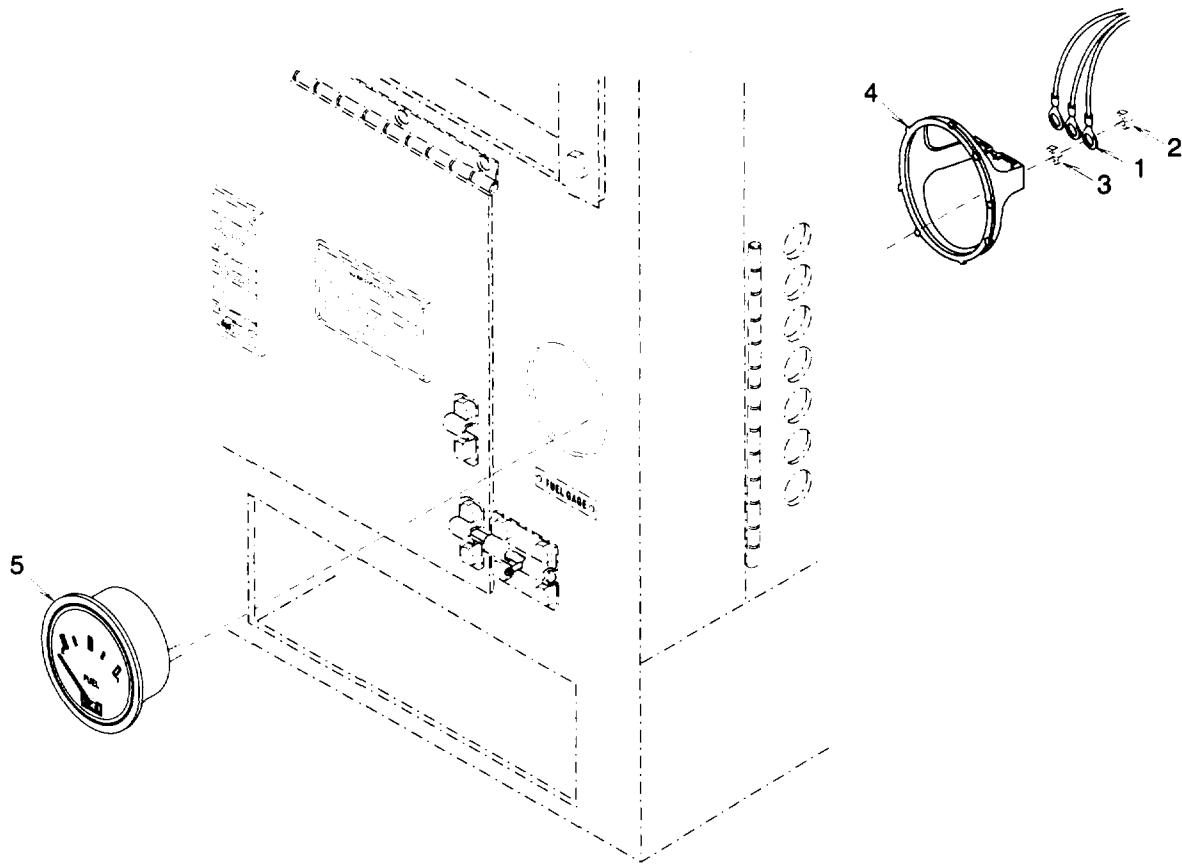

Figure 4-59. Fuel Gage

NOTE

FOLLOW-ON MAINTENANCE:
 Close right side door.
 Connect battery (para 4-35) and put unit back into service.

4-66. SENDING UNIT REPLACEMENT.

This task covers:**a. Removal****b. Installation**

INITIAL SETUP

Materials/ Parts:

Lock Washers (5)
1, Appendix G
Marker tags (2)
4, Appendix E

Equipment Conditions:

Refrigeration unit shut down (para 2-7) and battery
disconnected (para 4-35).
Left side door open.

a. Removal.**NOTE****Terminal hardware is supplied with sending unit.**

- (1) Tag wire leads (1).
- (2) Remove two nuts (2) and wire leads (1).
- (3) Remove five screws (3), lock washers (4) and fuel level sender (5). Discard lock washers.

b. Installation.

- (1) Install fuel level sender (5), five new lock washers (4), and screws (3).

NOTE**Terminal hardware is supplied with sending unit.**

- (2) Using tags and wiring diagram (fig. 1-4), install wire leads (1) and secure using two nuts (2). Remove tags.

4-66. SENDING UNIT REPLACEMENT. - Continued

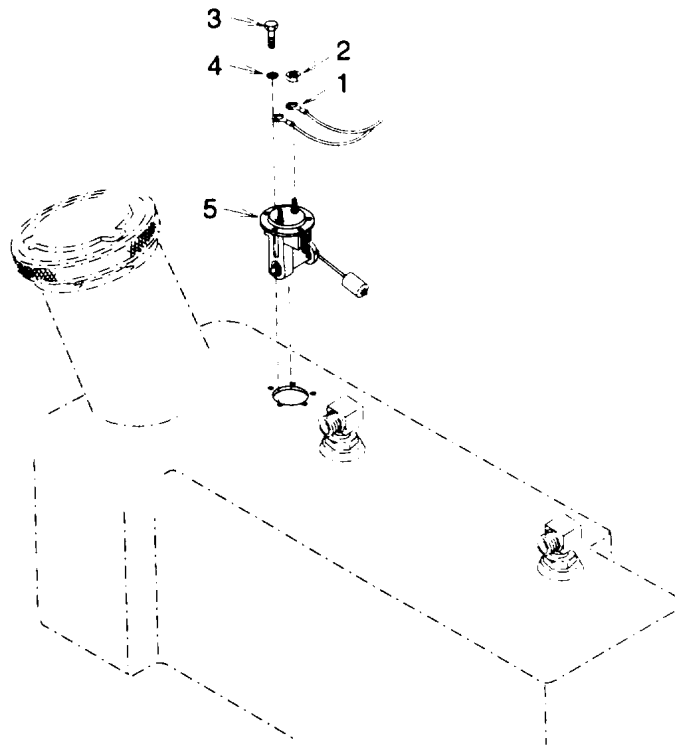

Figure 4-60. Sending Unit

NOTE

FOLLOW-ON MAINTENANCE:

Close left side door.

Connect battery (para 4-35) and put unit back into service.

4-67. FUEL TANK REPAIR AND REPLACEMENT.**This task covers:****a. Removal****b. Repair****c. Installation****INITIAL SETUP**Materials/Parts:

Nuts (2)
 24, Appendix G
 Ferrule Tubes (2)
 25, Appendix G
 Connectors (2)
 26, Appendix G
 Lock Washers (6)
 1, Appendix G
 Lock Washers (5)
 22, Appendix G

Materials/Parts:

Marker tags (4)
 4, Appendix E
 Tie Down Straps
 5, Appendix E

Equipment Conditions:

Refrigeration unit shut down (para 2-7) and battery disconnected (para 4-35).
 Both side doors open.
 Control box cover raised and latched.

a. Repair.**NOTE****Repair is limited to replacement of damaged components.**

(1) Fuel Tank Filler Neck.

- (a) Remove cap (1) and unlatch chain (2).
- (b) Remove six screws (3), lock washers (4), and fuel tank filler neck (5). Discard lock washers.
- (c) Install new fuel tank filler neck (5), six new lock washers (4), and screws (3).
- (d) Latch chain (2) in place and install cap (1).

(2) Fuel Level Sender.

- (a) Tag wire leads (6) and remove two nuts (7), wire leads, nuts (8), and flat washers (9).
- (b) Remove five screws (10), lock washers (11), and fuel level sender (12). Discard lock washers.
- (c) Install new fuel level sender (12), five new lock washers (11), and screws (10).
- (d) Using tags and wiring diagram (fig 1-4), install two flat washers (9), nuts (8), wire leads (6), and nuts (7). Discard tags.

4-67. FUEL TANK REPAIR AND REPLACEMENT. - Continued

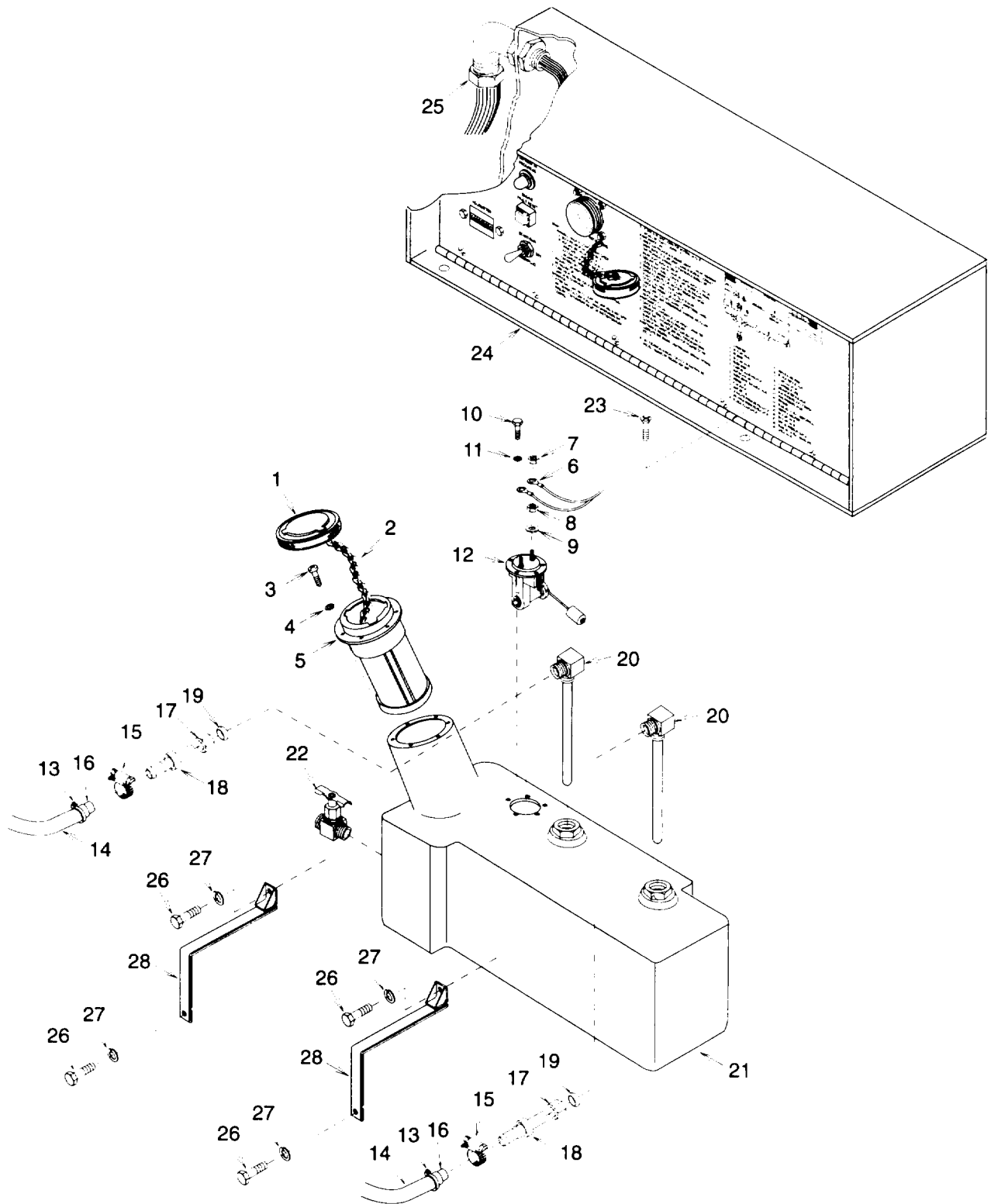

Figure 4-61. Fuel Tank

NOTE

The following procedure applies to both inlet elbows. Quantities given are for each.

(3) Fuel Inlet Elbow.

- (a) Cut tie down straps (13) as necessary and pull loom (14) back to expose clamp (15).

NOTE

It may be necessary to cut hose to remove it.

- (b) Loosen clamp (15) and remove hose (16).
- (c) Remove fuel tank per step b. below.
- (d) Loosen nut (17) then remove connector (18) and tube ferrule (19). Discard nut, connector, and tube ferrule.
- (e) Remove fuel inlet elbow (20).
- (f) Install new fuel inlet elbow (20).
- (g) Install new nut (17) and new tube ferrule (19) onto new connector (18). Install connector into fuel inlet elbow (20) and tighten nut to compress tube ferrule.
- (h) Install fuel tank per step c. below.
- (i) Slide clamp (15) over hose (16) end and install hose onto connector (18). Tighten clamp.
- (j) Pull loom (14) over hose (16) end and secure using tie down straps (13) as necessary.

(4) Shut-Off Cock.

- (a) Drain fuel tank (21) (para 4-7).
- (b) Remove shut-off cock (22).
- (c) Install new shut-off cock (22).
- (d) Fill fuel tank (21) with appropriate type and quantity fuel (para 4-7).

b. Removal.

- (1) Drain fuel tank (21) (para 4-7).
- (2) Remove six screws (23) and carefully slide control box assembly (24) out as far as the strain relief bushing (25) will allow.
- (3) Tag wire leads (6) then remove two nuts (7) and wire leads.
- (4) Cut tie down straps (13) as necessary and pull loom (14) back to expose clamps (15).

4-67. FUEL TANK REPAIR AND REPLACEMENT. - Continued**NOTE**

It may be necessary to cut hose to remove it.

- (5) Tag each hose (16) then loosen two clamps (15) and remove hoses.
- (6) Remove four bolts (26), lock washers (27), and two straps (28). Discard lock washers.
- (7) Carefully slide fuel tank (21) toward control box assembly (24) and remove through left side door.
- (8) Remove cap (1) and un-latch chain (2).
- (9) Remove six screws (3), lock washers (4), and fuel tank filler neck (5). Discard lock washers.
- (10) Remove five screws (10), lock washers (11), and fuel level sender (12). Discard lock washers.

NOTE

Connector, nut, and tube ferrule cannot be re-used. If removed, they must be replaced.

- (11) Remove two fuel inlet elbows (20).
- (12) Remove shut-off cock (22).

c. Installation.

- (1) Install shut-off cock (22).

NOTE

Connector, nut, and tube ferrule cannot be re-used. If removed, they must be replaced.

- (2) Install two fuel inlet elbows (20).
- (3) Install fuel level sender (12), five new lock washers (11), and screws (10).
- (4) Install fuel tank filler neck (5), six new lock washers (4), and screws (3).
- (5) Latch chain (2) in place and install cap (1).
- (6) Slide tank (21) into position.
- (7) Install two straps (28), four new lock washers (27), and bolts (26).
- (8) Slide one clamp (15) over each hose (16) end and using tags, install each hose onto appropriate connector (18). Tighten clamps.
- (9) Pull loom (14) over each hose (16) end and secure using tie down straps (13) as necessary.

- (10) Using tags and wiring diagram (fig 1-4), install wire leads (6), and two nuts (7). Discard tags.
- (11) Slide control box assembly (24) back into position.
- (12) Install six screws (23).
- (13) Fill fuel tank (21) with appropriate type and quantity fuel (para 4-7).

NOTE

FOLLOW-ON MAINTENANCE:
Unlatch and close control box cover door.
Close both side doors.
Connect battery (para 4-35) and put unit back into service.

4-68. GASKET (HEAT SHIELD) REPLACEMENT.

This task covers:

a. Removal

b. Installation

INITIAL SETUP

Materials/Parts:

- Silicone RTV
1, Appendix E
- Gasket
F-12, Appendix F
- Gasket
F-13, Appendix F

Equipment Conditions:

Refrigeration unit removed from refrigerator enclosure (para 4-6).

a. Removal.

NOTE

Remove only the individual gasket pieces that need to be replaced.

- (1) Remove eight screws (1), two gasket retainer strips (2), and top gasket (3). Repeat for bottom gasket.
- (2) Remove eight screws (4), two gasket retainer strip (5), and left side gasket (6). Repeat for right side gasket.

b. Installation.

- (1) Coat the cut surfaces of gasket(s) (3) and/or (6) with silicone RTV to seal foam.
- (2) Install left side gasket (6), two gasket retainer strips (5), and eight screws (4). Repeat for right side.
- (3) Install top gasket (3), two retainer strips (2), and eight screws (1). Repeat for bottom gasket.
- (4) Seal four seams (7) with silicone RTV.

4-68. GASKET (HEAT SHIELD) REPLACEMENT. - Continued

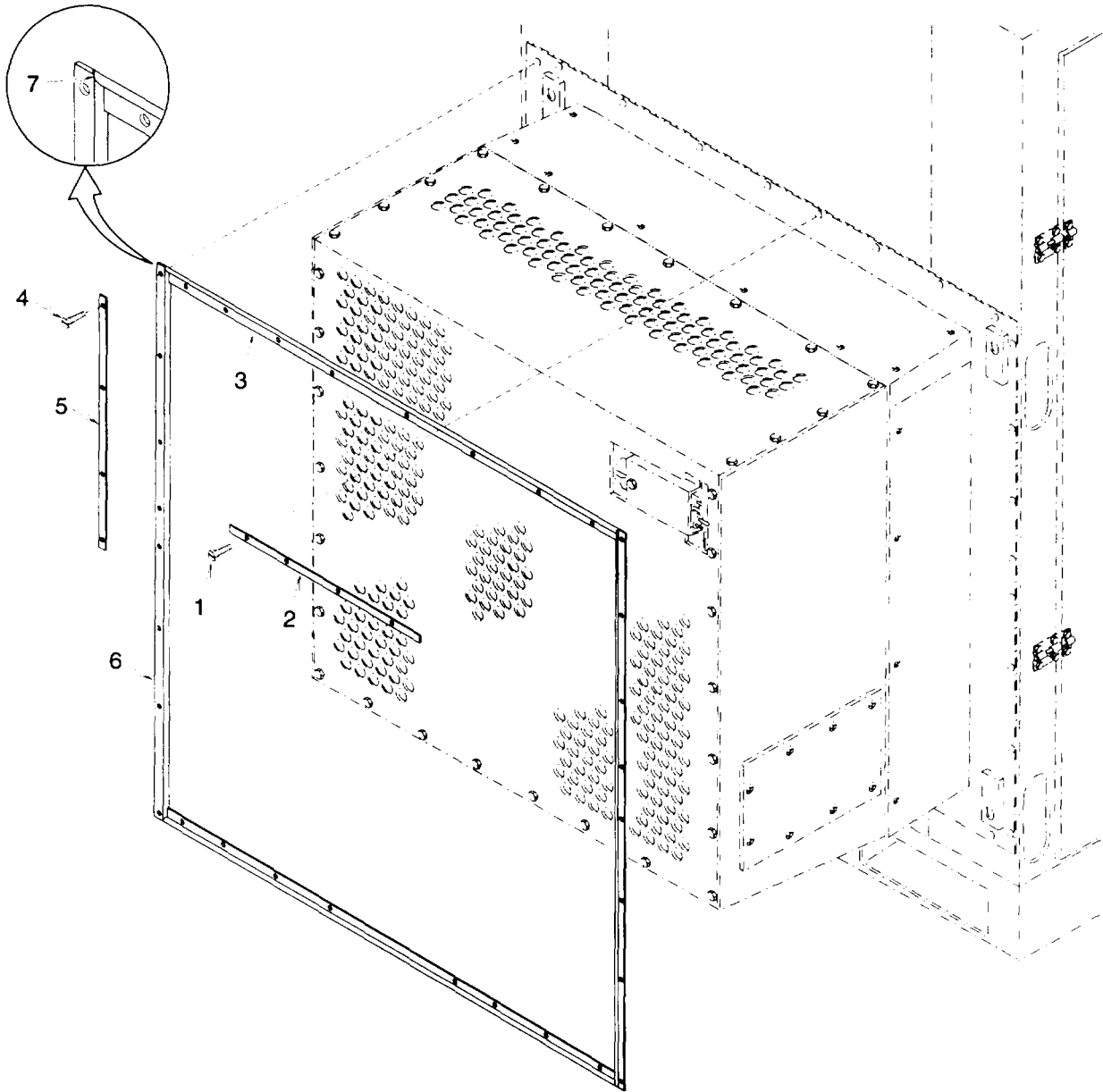

Figure 4-62. Gasket (Heat Shield)

NOTE

FOLLOW-ON MAINTENANCE:
Install refrigeration unit onto refrigerator enclosure (para 4-6).

SECTION VI PREPARATION FOR STORAGE OR SHIPMENT**4-69. ADMINISTRATIVE STORAGE.**

Placement of equipment in administrative storage should be for short periods of time (1 to 45 days) when a shortage of maintenance effort exists. Items should be in mission readiness within 24 hours or within the time factors as determined by the directing authority. During the storage period, appropriate maintenance records will be kept.

- a. Placing the equipment in administrative storage. Before placing the equipment in administrative storage, all current preventive maintenance checks and services should be completed. Shortcomings and deficiencies should be corrected, and all Modification Work Orders (MWO) should be applied.
- b. Storage site selection. Inside storage is preferred for items selected for administrative storage. If inside storage is not available, trucks, vans, conex containers, and other containers may be used.
- c. Pump down refrigeration unit.

WARNING

Exposed rotating parts are contained in the refrigeration unit. Personal injury can result if access doors are opened when battery is connected.

NOTE

Refrigeration unit should be pumped down if out of service for longer than 5 days.

- (1) Be sure refrigeration unit is shut down (para 2-7) then remove two isolation valve caps (1) and shut off valve caps (2).
- (2) Close hot gas stop valve (3).
- (3) Close receiver outlet valve (4).
- (4) Be sure both condenser side doors are closed then operate the refrigeration unit (para 2-7) until it shuts down automatically.
- (5) Close receiver inlet valve (5), both compressor shut off valves (6), and liquid stop valve (7).
- (6) Install two shut off valve caps (2) and isolation valve caps (1).
- (7) Disconnect battery (para 4-35).
- (8) Place a marker tag (4, appendix E) on or near the control panel cover stating "THE REFRIGERATION UNIT HAS BEEN PUMPED DOWN, DO NOT OPERATE UNTIL ALL VALVES HAVE BEEN PROPERLY SET, EQUIPMENT DAMAGE WILL OCCUR."

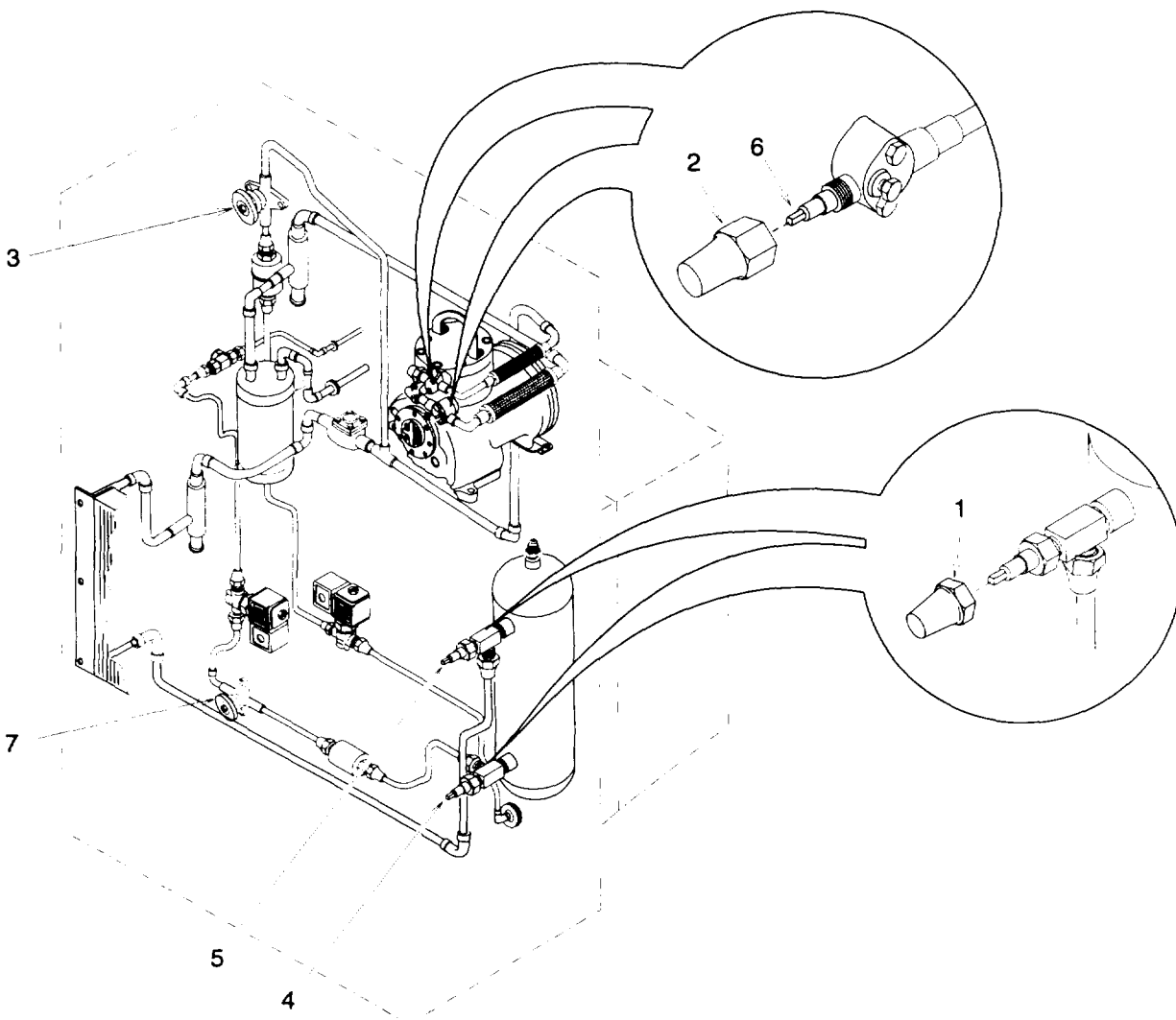

Figure 4-63. Refrigeration System Pump Down

4-70. LONG TERM STORAGE OR SHIPMENT.

Placement of equipment in long term storage should be for extended periods of time (45 days or more).

- a. Before placing the equipment in long term storage, current preventive maintenance checks and services should be completed, shortcomings and deficiencies should be corrected, and all Modification Work Orders (MWO) should be applied.
- b. If refrigeration unit has not been in operation, operate the unit (para 2-7) for 15 minutes.
- c. Open both side doors and front door.

NOTE

Refrigerant and refrigerant lubricating oil will not be removed from the refrigerant system.

- d. Drain engine crankcase (para 4-7) and fill with preservative oil MIL-L-21260, T930 (30, Appendix E).
- e. Drain fuel tank (para 4-7).
- f. Disconnect fuel supply hose from fuel tank (para 4-62). Route hose through front door and insert into a container of preservative oil VV-L-800, T900 (31, Appendix E).

NOTE

Operation for short periods of time with preservative oils installed will not cause appreciable engine damage.

- g. Remove fuel tank fill cap and be sure both side condenser doors are closed. Operate the refrigeration unit (para 2-7) until preservative oil is observed flowing into fuel tank. Pump down the refrigeration unit (para 4-69). Shut down refrigeration unit (para 2-7) and install fuel tank fill cap.
- h. Loosen V-belts (para 4-38).
- i. Place a marker tag (4, appendix E) on or near the control panel cover stating "THE REFRIGERATION UNIT ENGINE AND FUEL SYSTEM HAVE BEEN PRESERVED, DO NOT OPERATE UNTIL ALL FLUIDS HAVE BEEN DRAINED AND PROPER QUANTITY AND TYPE INSTALLED, EQUIPMENT DAMAGE WILL OCCUR."
- j. Open left side door and connect fuel supply hose onto fuel tank (para 4-62).
- k. Remove air cleaner adapter (para 4-50) and spray 1 oz (30 cc) MIL-C-16173 (32, Appendix E) into engine air intake manifold. Install air cleaner adapter (para 4-50).
- l. Spray or brush MIL-C-16173 (32, Appendix E) onto any unpainted surfaces.
- m. Close left side door and front door.
- n. Preserve the refrigeration unit in accordance with MIL-P-116, method I.
- o. Cover all openings into the evaporator panel, glass gages, name plates and instruction panels, switches, control boxes, engine, etc. with waterproof paper or a barrier material conforming to grade A, PP-C-843 (33, Appendix E) and secured in place with tape conforming to PPP-T-60 (34, Appendix E).
- p. Package the refrigeration unit in accordance with ASTM D 3951, level A or Commercial.
- q. Refrigeration unit shall be packed upright in a cleated plywood box conforming to style B, type 3 load, PPP-B-601 for overseas. Each unit shall be secured and the container closed and strapped with 3/4 inch by 0.023 inch steel. The strapping shall be applied over the horizontal top, bottom, and intermediate cleats of the side and ends.
- r. Shipping containers shall be marked with the words "UP" and "THIS SIDE DOWN" shall appear on each shipping container.

4-167/(4-168 blank)

CHAPTER 5

DIRECT SUPPORT MAINTENANCE INSTRUCTIONS

SECTION I DIRECT SUPPORT TROUBLESHOOTING INSTRUCTIONS

5-1. TROUBLESHOOTING.

The following procedures are listed in order of the most probable malfunctions. Each malfunction is followed by test or inspection procedures in logical order to isolate and identify the fault and actions required to correct it. This section cannot list all the possible malfunctions that may occur with the equipment. If a malfunction occurs that is not listed or actions listed do not correct a malfunction, notify your supervisor.

a. Engine Cranks But Will Not Start Or Stops During Operation

CLEAN AND TEST INJECTOR NOZZLES (PARA 5-42).
REPLACE IF NEEDED. DOES ENGINE
START/RUN (PARA 2-5)?

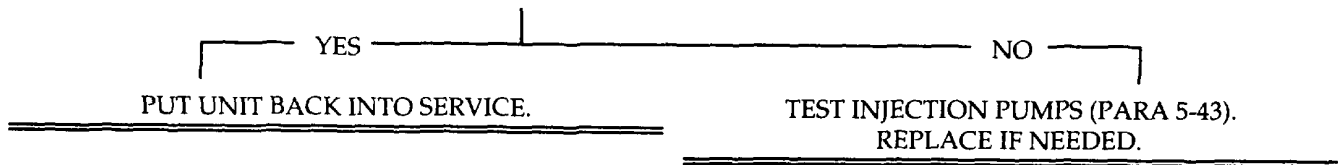

b. Pressure Gage Indicates Above Operating Range.

INSTALL SERVICE MANIFOLD (PARA 5-9) AND
OPERATE REFRIGERATION UNIT (PARA 2-5). DOES
SERVICE MANIFOLD GAGE READING MATCH
PRESSURE GAGE READING?

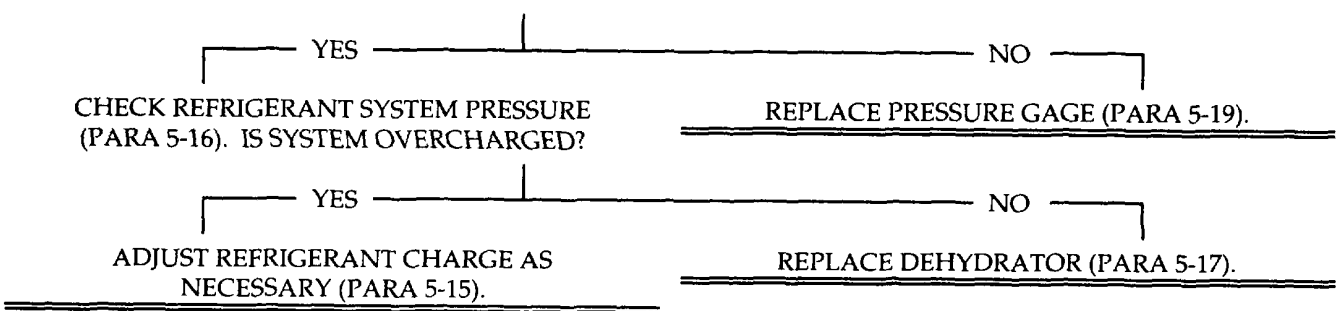

5-1. TROUBLESHOOTING. - Continued

c. Compressor Operates For Short Period Then Stops.

OPERATE REFRIGERATION UNIT (PARA 2-5) AND
OBSERVE COMPOUND GAGE. DOES
PRESSURE DROP RAPIDLY?

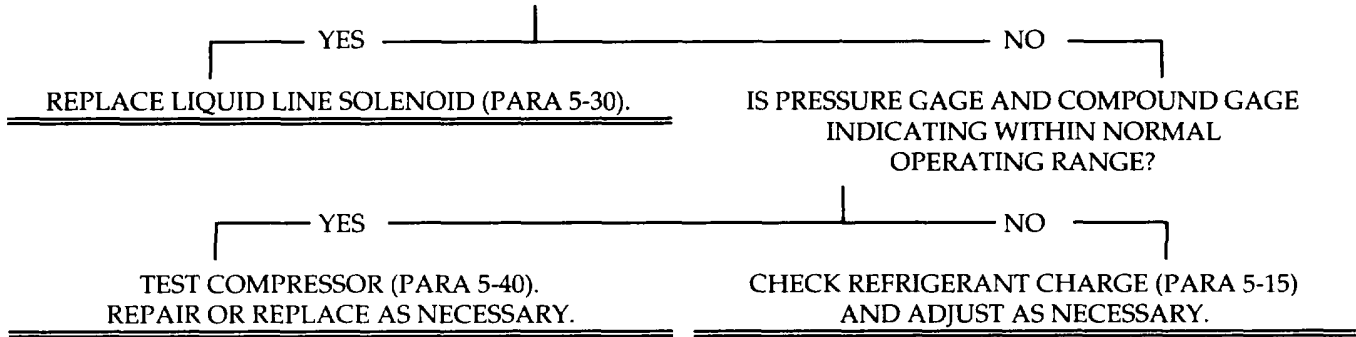

d. Pressure Readings Low/Insufficient Cooling.

SHUT DOWN REFRIGERATION UNIT (PARA 2-7).
DOES THE REFRIGERATION UNIT STOP RUNNING?

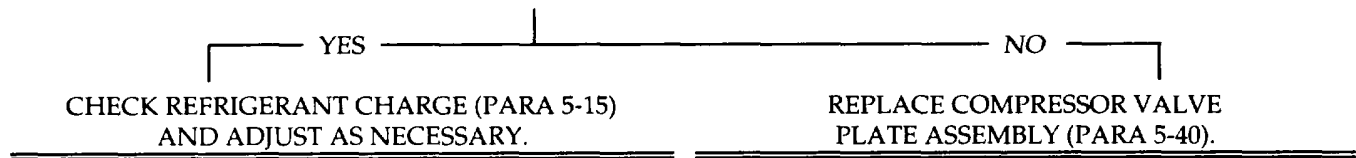

SECTION II DIRECT SUPPORT MAINTENANCE INSTRUCTIONS

5-2. CONTROL BOX COVER REPAIR AND REPLACEMENT.

This task covers:

a. Removal

b. Repair

c. Installation.

INITIAL SETUP

Materials/Parts:

General Purpose Adhesive
19, Appendix E

Wiping Rag
9, Appendix E

Acetone
20, Appendix E

Methyl-Ethyl Ketone
21, Appendix E

Rivets (12)
27, Appendix G

Rivets (11)
45, Appendix G

Gasket
4, Figure F-3, Appendix F

Gasket F
5, Figure F-3, Appendix F

Gasket
6, Figure F-3, Appendix F

Gasket
7, Figure F-3, Appendix F

Materials/Parts:

Gasket
1, Figure F-10, Appendix F

Gasket
2, Figure F-10, Appendix F

Gasket
Figure F-11, Appendix F

General Safety Instructions:

WARNING

Acetone and methyl-ethyl ketone (MEK) are flammable and their vapors can be explosive. Repeated or prolonged skin contact or inhalation of vapors can be toxic. Use in a well ventilated area, wear gloves, and keep away from sparks or flame.

a. Removal.

- (1) Using drill bit slightly smaller than rivet diameter, drill through 11 rivets (1) and remove control box cover (2).
- (2) Using drill bit slightly smaller than rivet diameter, drill through 12 rivets (3) and remove data plates (4), (5), and (6).

b. Repair.

- (1) Remove as much old gasket material (7), (8), (9), (10), (11), (12), or (13) as possible by pulling or scraping it away from the control box cover (2).
- (2) Soften and remove old adhesive and gasket (7), (8), (9), (10), (11), (12), or (13) residue, using acetone or methyl-ethyl ketone (MEK) and a stiff brush.

5-2. CONTROL BOX COVER REPAIR AND REPLACEMENT. - Continued

Figure 5-1. Control Box Cover Assembly

- (3) Be sure that the attaching surface of the control box cover (2) is clean and free of paint and old adhesive material.
- (4) Coat the mating surfaces of the control box cover (2) and gaskets (7), (8), (9), (10), (11), (12), or (13) with adhesive. Let both surfaces air dry until adhesive is tacky, but will not stick to fingers.
- (5) Starting with an end, carefully press gasket (7), (8), (9), (10), (11), (12), or (13) onto control box cover (2). Press firmly overall to ensure complete contact.

c. Installation.

- (1) Install data plates (4), (5), and (6) and secure using 12 rivets (3).
- (2) Install control box cover (2) and secure using 11 rivets (1).

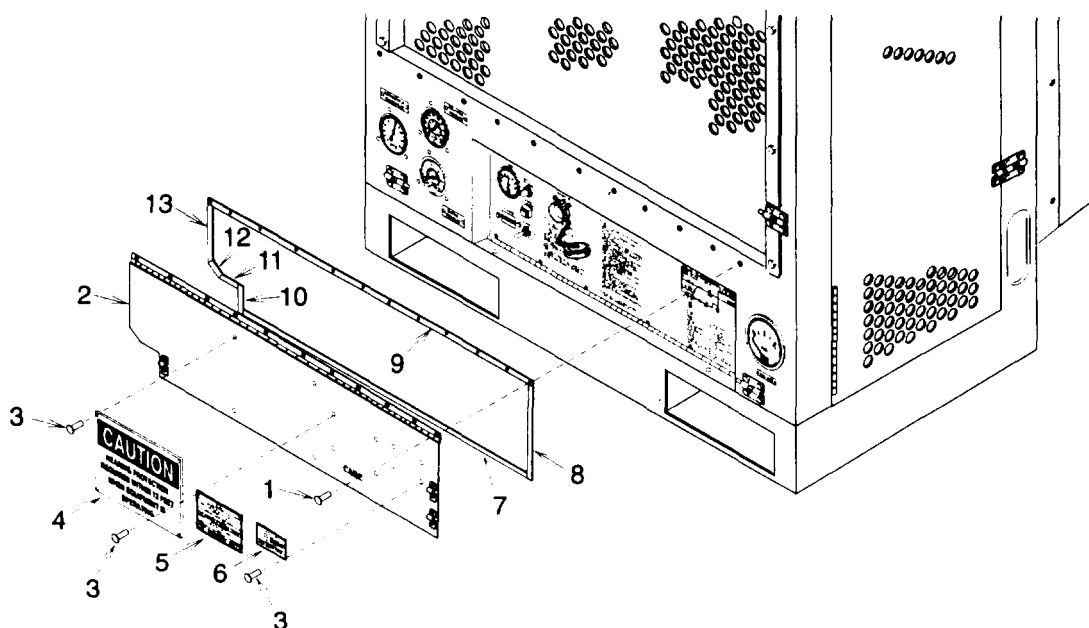
5-3. ACCESS PANEL REPAIR.

This task covers:
Repair

INITIAL SETUPMaterials/Parts:

Adhesive, General Purpose
19, Appendix E

Wiping Rag
9, Appendix E

Acetone
20, Appendix E

Methyl Ethyl Ketone
21, Appendix E

Gaskets (2)
1, Figure F-3, Appendix F

Gaskets (2)
2, Figure F-3, Appendix F

Equipment Conditions:

Access panel removed (para 4-16).

General Safety Instructions:**WARNING**

Acetone and methyl-ethyl ketone (MEK) are flammable and their vapors can be explosive. Repeated or prolonged skin contact or inhalation of vapors can be toxic. Use in a well ventilated area, wear gloves, and keep away from sparks or flame.

Repair.

- (1) Remove as much old gasket material (1) or (2) as possible by pulling or scraping it away from the access panel (3). Soften and remove old adhesive and gasket residue, using acetone or methyl-ethyl ketone (MEK) and a stiff brush.
- (2) Be sure that the attaching surface of the access panel (3) is clean and free of paint and old adhesive material.
- (3) Coat the mating surfaces of the access panel (3) and gasket (1) or (2) with adhesive. Let both surfaces air dry until adhesive is tacky, but will not stick to fingers. Starting with an end, carefully press gasket (1) or (2) onto the access panel (3). Press firmly overall to ensure complete contact.

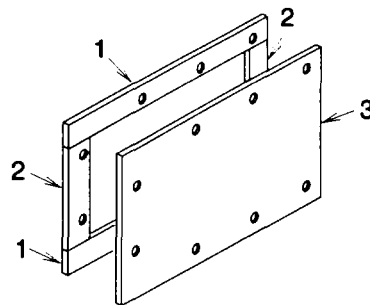

Figure 5-2. Access Panel

NOTE

FOLLOW-ON MAINTENANCE:
Install access panel (para 4-16).

5-4. CONTROL PANEL REPAIR.

**This task covers:
Repair**

INITIAL SETUP

Materials/Parts:

Lock Washers (2)
1, Appendix G
General Purpose Adhesive
19, Appendix E
Wiping Rag
9, Appendix E
Acetone
20, Appendix E
Methyl-Ethyl Ketone
21, Appendix E
Gasket
Figure F-8, Appendix F
Gaskets (2)
3, Figure F-3, Appendix F

Equipment Conditions:

Refrigeration unit shut down (para 2-7) and battery disconnected (para 4-35).
Control box cover door raised and latched.

General Safety Instructions:

WARNING

Acetone and methyl-ethyl ketone (MEK) are flammable and their vapors can be explosive. Repeated or prolonged skin contact or inhalation of vapors can be toxic. Use in a well ventilated area, wear gloves, and keep away from sparks or flame.

Repair.

NOTE

Repair is limited to replacement of gasket material.

- (1) Remove two bolts (1) and lock washers (2). Open control panel (3). Discard lock washers.
- (2) Remove as much old gasket material (4) or (5) as possible by pulling or scraping it away from the control panel (3).
- (3) Soften and remove old adhesive and gasket (4) or (5) residue, using acetone or methyl-ethyl ketone (MEK) and a stiff brush.
- (4) Be sure that the attaching surface of the control panel (3) is clean and free of paint and old adhesive material.
- (5) Coat the mating surfaces of the control panel (3) and gasket (4) or (5) with adhesive. Let both surfaces air dry until adhesive is tacky, but will not stick to fingers.

(6) Starting with an end, carefully press gasket (4) or (5) onto the control panel (3). Press firmly overall to ensure complete contact.

(7) Close control panel (3) and install two new lock washers (2) and bolts (1).

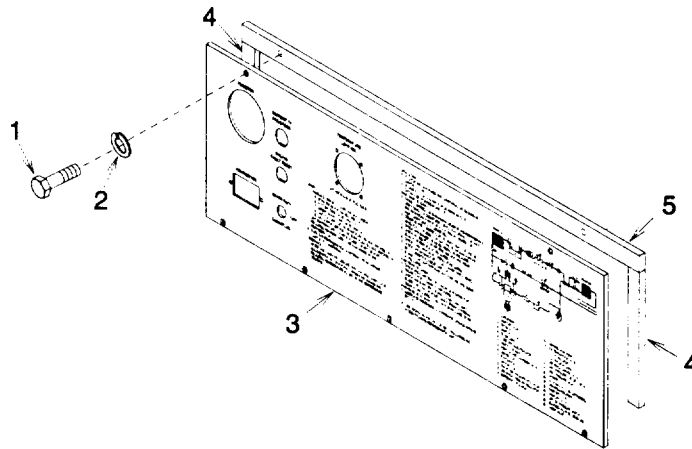

Figure 5-3. Control Panel

NOTE

FOLLOW-ON MAINTENANCE:

Unlatch and close control box cover door.
Connect battery (para 4-35) and put unit back into service.

5-5. BATTERY SHIELD REPAIR

This task covers:**Repair**

INITIAL SETUPMaterials/Parts:Self Locking Nuts (4)
7, Appendix G

Gasket

Figure F-33, Appendix F

Gasket (2)

10, Figure F-3, Appendix F

Equipment Conditions:Refrigeration unit shut down (para 2-7) and battery
disconnected (para 4-35).Right side door open.

Repair.

- (1) Remove four self locking nuts (1), flat washers (2), and battery clamp (3). Discard self locking nuts.
- (2) Remove two L-bolts (4), and shield (5).
- (3) Remove as much old gasket material (6) or (7) as possible by pulling or scraping it away from the shield (5).
- (4) Soften and remove old adhesive and gasket (6) or (7) residue, using acetone or methyl-ethyl ketone (MEK) and a stiff brush.
- (5) Be sure that the attaching surface of the battery shield (5) is clean and free of paint and old adhesive material.
- (6) Coat the mating surfaces of the shield (5) and gasket (6) or (7) with adhesive. Let both surfaces air dry until adhesive is tacky, but will not stick to fingers.
- (7) Starting with an end, carefully press gasket (6) or (7) onto the shield (5). Press firmly overall to ensure complete contact.
- (8) Install two L-bolts (4) and slide shield (5) into position.
- (9) Install clamp (3), four flat washers (2), and new self locking nuts (1).

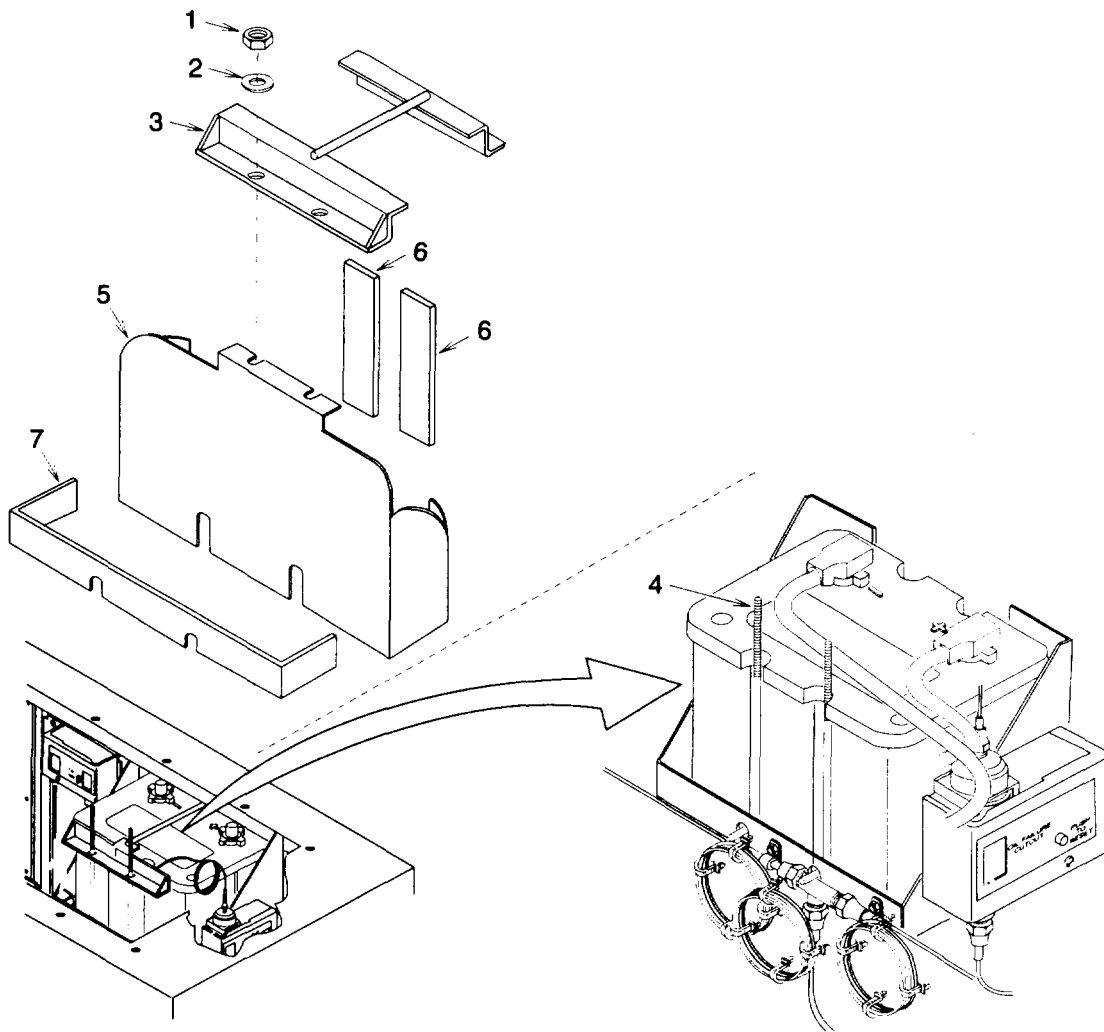

Figure 5-4. Battery Shield

NOTE

FOLLOW-ON MAINTENANCE:

Close right side door.
Connect battery (para 4-35) and put unit back into service.

5-6. COMPRESSOR PULLEY REPLACEMENT.**This task covers:****a. Removal****b. Installation****INITIAL SETUP****Materials/Parts:**

Lock Washer
12, Appendix G

Equipment Conditions:

Refrigeration unit shut down (para 2-7) and battery disconnected (para 4-35).
Compressor removed (para 5-40).

a. Removal.

- (1) Remove bolt (1), lock washer (2), and two flat washers (3). Discard lock washer.
- (2) Slide pulley (4) off compressor shaft (5) being careful not to lose key (6).

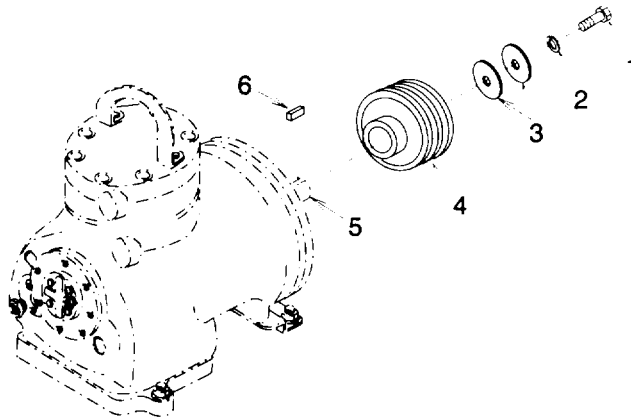
**Figure 5-5. Compressor Pulley****b. Installation.**

- (1) Install key (6) then align pulley (4) with key and slide onto compressor shaft (5).
- (2) Install two flat washers (3), new lock washer (2), and bolt (1).

NOTE**FOLLOW-ON MAINTENANCE:**

Install compressor (para 4-40).
Install V-belt onto pulley and adjust (para 4-38).
Connect battery (para 4-35) and put unit back into service.

5-7. FAN DRIVE SHAFT REPLACEMENT.

 This task covers:

a. Removal

b. Installation

INITIAL SETUP**Equipment Conditions:**

Refrigeration unit shut down (para 2-7) and battery disconnected (para 4-35).

Evaporator fan removed (para 4-41).

Fan clutch removed (para 4-46).

Condenser coil removed (para 5-23).

- a. **Removal.** Loosen two set screws (1) on each flange bearing (2) and remove fan drive shaft (3).
- b. **Installation.** Install fan drive shaft (3) and tighten two set screw (1) on each flange bearing (2).

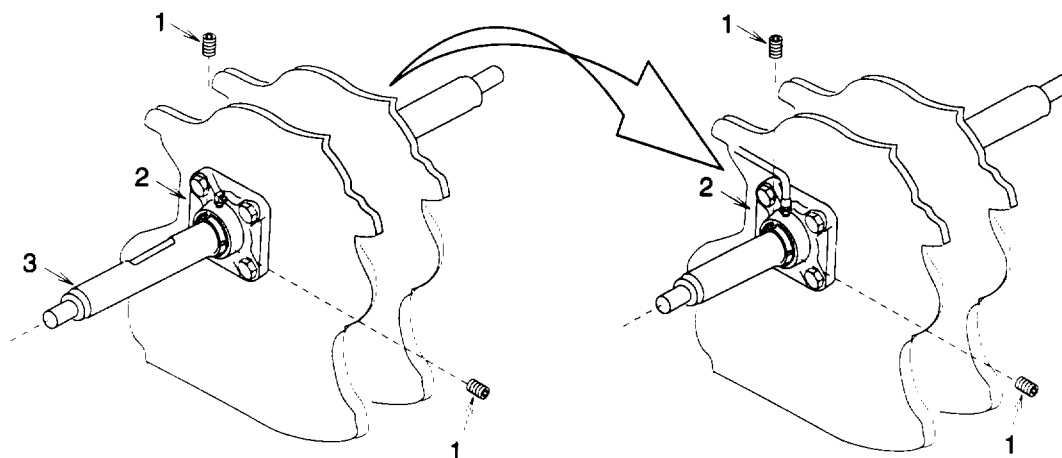
**Figure 5-6. Fan Drive Shaft****NOTE****FOLLOW-ON MAINTENANCE:**

Install evaporator fan (para 4-41).

Install fan clutch (para 4-46).

Install condenser fan (para 4-40).

Install condenser coil (para 5-23).

Connect battery (para 4-35) and put unit back into service.

5-8. REFRIGERATION SYSTEM REPAIRS.

The refrigeration system must be totally discharged (para 5-10) before any maintenance is performed on system components. Leak testing (para 5-13) and dehydrator replacement (para 5-17) are required after any system component has been removed and replaced. The system must be properly evacuated (para 5-14) and charged (para 5-15) to function correctly.

5-9. SERVICE MANIFOLD INSTALLATION.

This task covers:**a. Installation****b. Removal**

INITIAL SETUP**Tools:**

Refrigeration Unit Service Tool Kit
4, Section III, Appendix B
Refrigerant Recovery and Recycle Unit
5, Section III, Appendix B

Equipment Conditions:

Refrigeration unit shut down (para 2-7) and battery disconnected (para 4-35)
Front door and right side door open.

General Safety Instructions:**WARNING**

Compressor lubricating oil used in this refrigeration system is caustic. Wear gloves and a face protector or safety glasses in any situation where skin or eye contact is possible. If oil does contact skin, wash with soap and water.

General Safety Instructions:**WARNING**

- Heat may cause the refrigerant to decompose and release irritating, toxic, and corrosive gases. Prevent contact of refrigerant with flame or hot surfaces.
- Rotating parts are used in the refrigeration unit. Personal injury can result if battery is connected.
- Dangerous chemical refrigerant under pressure is used in the operation of this equipment. Use great care to avoid contact with liquid refrigerant. Work in a well ventilated area.
- Sudden and irreversible tissue damage can result from freezing. Wear gloves and face protector or safety glasses in any situation where skin or eye contact with refrigerant is possible.

a. Installation.**CAUTION**

Using excessive force when opening or closing valves can cause damage to the valve seats.

NOTE

The compressor shut off valves can be adjusted to three positions, fully closed to block the refrigerant tubes and isolate the compressor and service port, fully open to allow flow from piping to compressor but not the service port, and cracked (one turn closed from fully open) to allow flow from piping to compressor and service port on valve.

- (1) Remove two shut off valve caps and turn the shut off valves fully counterclockwise to back seat them.
- (2) Remove two flare coupling caps.
- (3) Check that all four service manifold valves are closed.

NOTE

Push switch in side door will prevent refrigeration unit from operating if door is open. Do not pass the service manifold hoses through the side door if the refrigeration unit will need to be operated.

- (4) Pass service manifold hoses through front door and connect service manifold pressure gage hose to discharge flare coupling and compound gage hose to suction flare coupling.
- (5) Connect service manifold charge hose to recovery unit.
- (6) Turn discharge and suction shut off valves one turn clockwise to crack open valves.
- (7) Open service manifold pressure gage valve and charge valve. Operate recovery unit and allow refrigerant to purge for 3-5 seconds. Close pressure gage and charge valves then shut down recovery unit.
- (8) Open service manifold compound gage valve and charge valve. Operate recovery unit and allow refrigerant to purge for 3-5 seconds. Close compound gage and charge valves then shut down recovery unit.

b. Removal.

- (1) Turn shut off valves fully counterclockwise to backseat them.
- (2) Open service manifold pressure and compound gage valves.
- (3) Open service manifold charge valve. Operate recovery unit and allow refrigerant to purge from hoses.
- (4) Close service manifold valves.
- (5) Shut down recovery unit.
- (6) Disconnect service manifold pressure gage hose from discharge flare coupling and compound gage hose from suction flare coupling.
- (7) Install two shut off valve and flare coupling caps.

5-9. SERVICE MANIFOLD INSTALLATION. - Continued

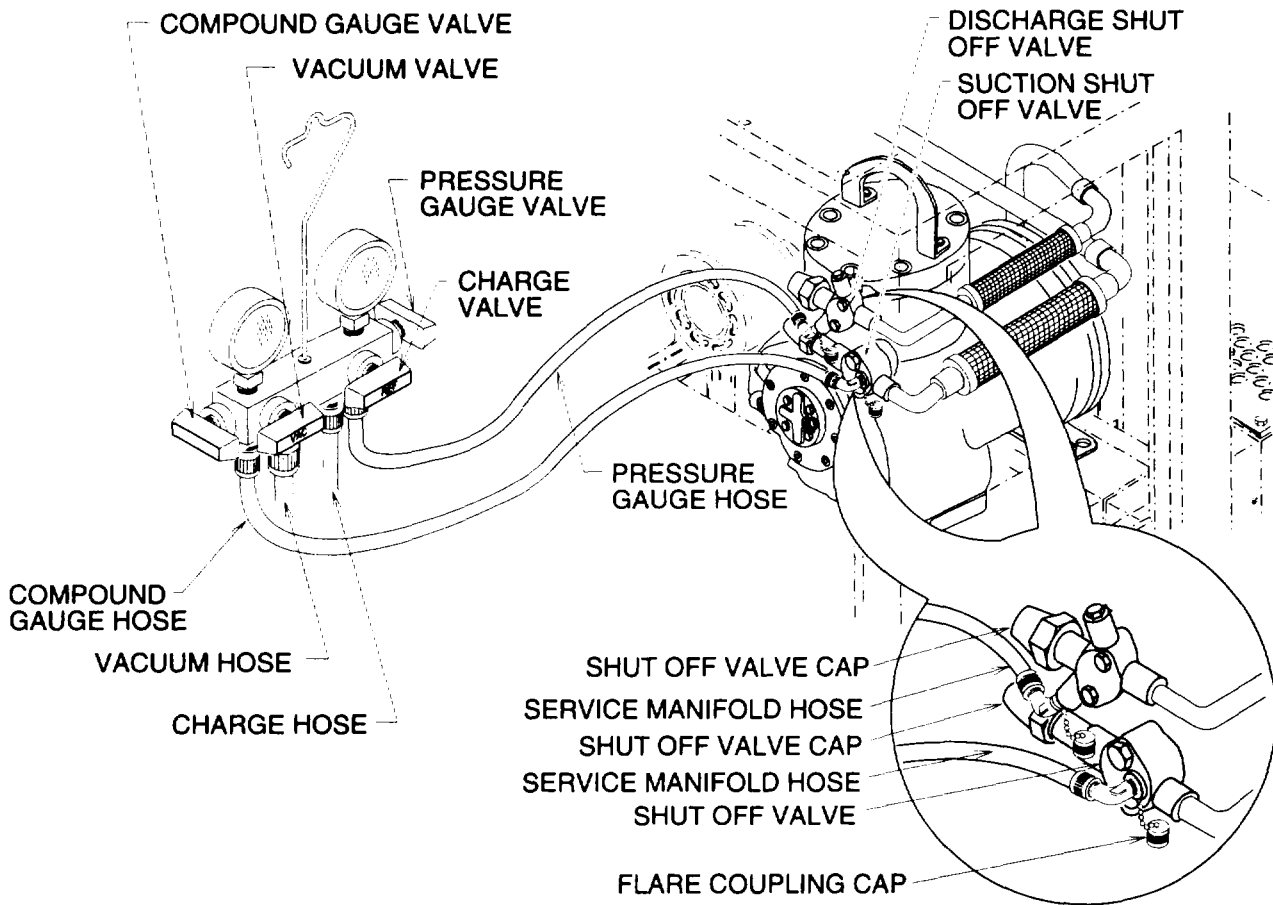

Figure 5-7. Service Manifold Installation

NOTE

FOLLOW-ON MAINTENANCE:
 Close front door.
 Close right side door.
 Connect battery (para 4-35) and put unit back into service.

5-10. DISCHARGING THE RFFRIGFRANT SYSTEM.

This task covers:

Discharging

INITIAL SETUP

Equipment Conditions:

Service manifold installed (para 5-9).

Discharge.

- (1) Check that the refrigerant system has not been pumped down (para 4-70). If it has, open necessary valves (para 4-8) to allow discharge of all refrigerant.

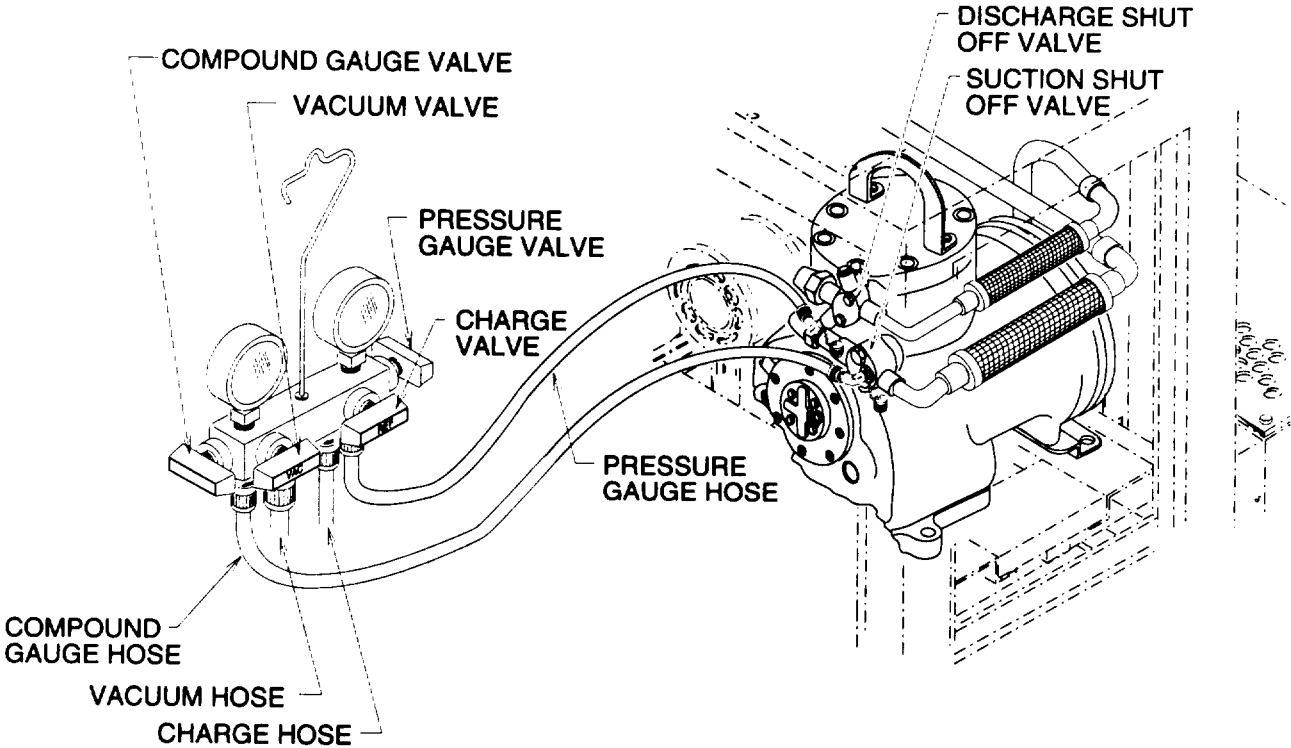

Figure 5-8. Discharging Refrigerant

5-10. DISCHARGING THE REFRIGERANT SYSTEM. - Continued**CAUTION**

Follow instructions for specific refrigerant recovery unit being used to avoid compressor oil loss. Loss of oil could result in compressor damage.

NOTE

Venting tetrafluoroethane refrigerant into the atmosphere rather than recovering it is subject to pending EPA restrictions. Venting the refrigerant may be a violation of public law and subject to severe penalties.

- (2) Open service manifold pressure and compound gage valves.
- (3) Open service manifold charge valve. Operate recovery unit until all refrigerant has been removed from system.
- (4) Close service manifold valves.
- (5) Shut-down refrigerant recovery unit.

5-11. PURGING THE REFRIGERANT SYSTEM.

This task covers:

Purging

INITIAL SETUP**Tools:**

Nitrogen Regulator
6, Section III, Appendix B

Materials/Parts:

Nitrogen
22, Appendix E

Equipment Conditions:

Refrigerant system discharged (para 5-10).injury.

General Safety Instructions:**WARNING**

- Never pressurize refrigerant lines with oxygen, mixture with oil could cause an explosion.
- The pressure in a nitrogen cylinder can exceed 2000 psi. A nitrogen pressure regulator should be used at all times to avoid personal injury.
- Nitrogen is an inert gas that can cause suffocation and must be discharged in a well ventilated area.

Purge. The item being serviced must be purged with dry nitrogen before and during brazing/debrazing operations to minimize internal oxidation and scaling.

- (1) Disconnect charge hose from recovery unit and connect to nitrogen regulator on nitrogertank.
- (2) Disconnect the manifold hoses from the compressor flare couplings.

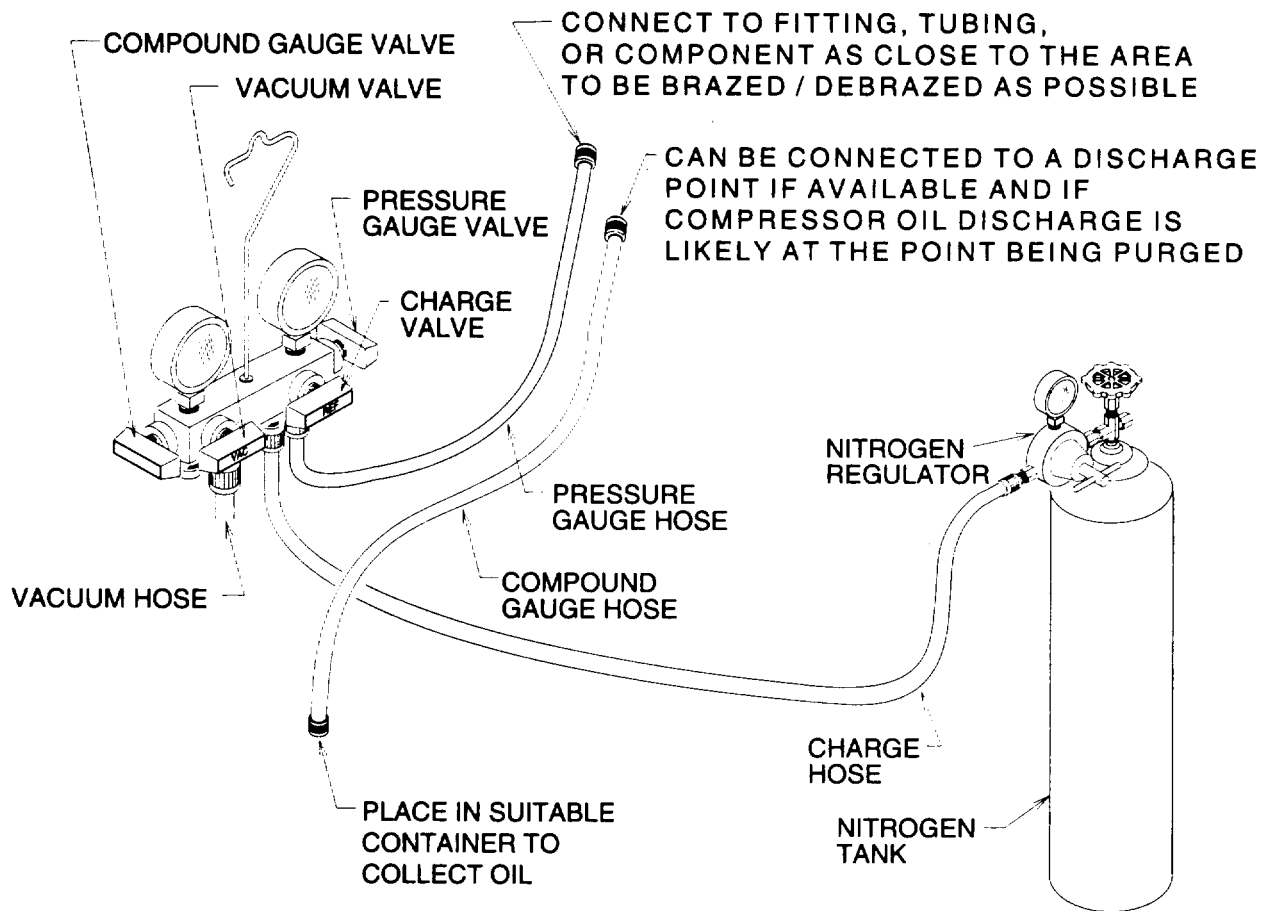

Figure 5-9. Nitrogen Tank Connection

- (3) Be sure the service manifold compound gage and vacuum valves are closed.
- (4) Open the service manifold pressure gage and charge valves.
- (5) Disconnect or remove any flare connection as necessary to allow un-restricted flow of nitrogen through item being brazed/debrazed.
- (6) Connect service manifold pressure gage hose to fitting, tubing, or component as necessary to allow free flow of nitrogen through item being brazed/debrazed.

WARNING

Performing service operations on refrigeration components when the system is pressurized can result in personal injury.

- (7) Open the nitrogen tank valve and adjust the regulator so that approximately 1-2 cfm (0.028-0.057 m³/minute) of nitrogen flows through the system. Do not allow pressure to build-up in system. Be sure nitrogen is flowing with no restrictions.

5-11. PURGING THE REFRIGERANT SYSTEM. - Continued

- (8) Check to be sure that no oil is being discharged during purge.
- (9) Perform any brazing/debrazing operations necessary (para 5-12).
- (10) When purging is completed, close nitrogen tank valve.
- (11) Disconnect the charge hose from nitrogen regulator.

5-12. BRAZING/DEBRAZING PROCEDURE.

This task covers:

a. Debrazing

b. Cleaning

c. Brazing

INITIAL SETUP

Materials/Parts:

- Brazing Alloy
23 or 24, Appendix E
- Brazing Flux
3, Appendix E
- Rags
9, Appendix E
- Abrasive Cloth
25, Appendix E

General Safety Instructions:

WARNING

Brazing alloys and flux contain materials which are hazardous to health. Avoid breathing vapors or fumes from brazing operations. Perform operations only in well ventilated areas. Wash hands with soap and water after handling brazing alloys and flux. Wear gloves and protective goggles or face shield to protect against burns.

Equipment Conditions:

Refrigerant system discharged (para 5-10) and purged (para 5-11).

a. Debraze.

- (1) Protect wiring harnesses and other components with appropriate heat shields.

NOTE

It may be easier to access a component by cutting or debrazing the copper lines in accessible areas and removing part of the interconnecting tubing with the component.

- (2) If debrazing a joint on a valve, disassemble the valve to the extent possible and wrap all but the joint with wet rag to act as a heat sink.

WARNING

- **Never use a heating torch on any part that contains refrigerant. Heat may cause the refrigerant to decompose and release irritating, toxic, and corrosive gases. All refrigerant must be discharged from the system and the entire system must be purged with dry nitrogen before beginning any brazing operation.**
- **Debrazing a joint when the system is pressurized can result in personal injury.**

CAUTION

- **If heat is applied slowly, or only on one side, the entire component or length of tubing will be heated and filler alloy in adjacent joints may also be melted.**
- **Brazing a joint without nitrogen flowing through the tubing, will cause deposits to form on the inside of the tube and may cause obstructions in the refrigeration system or equipment damage.**
 - (3) Check that the system is being purged (para 5-11) and that no pressure is being built-up in the system. Apply sufficient heat uniformly around the joint to quickly melt the filler alloy. Remove heat as soon as the joint is separated.
- b. Clean. All filler alloy must be cleaned from debrazed joints before reassembly. Heat each piece of the joint until the filler is melted and then wipe it away with a wire brush. Be sure no filler alloy or other debris is left inside any tubing, fitting, or component. Use abrasive cloth as necessary to clean joints.
- c. Braze.
 - (1) Protect wiring harnesses and other components with appropriate heat shields.

NOTE

- **All joints, except those provided with flare fittings, are made by brazing in accordance with MIL-B-7883, except that radiographic examination is not required.**
- **Grade IV or VI brazing alloy and Type-B flux, as specified in MIL-B7883, must be used for all copper to brass joints. Grade III brazing alloy may be substituted for Grade IV or VI for copper to copper joints, flux is not required for copper to copper joints.**
 - (2) If brazing a joint on a valve, disassemble the valve to the extent possible and wrap all but the joint with a wet rag to act as a heat sink.

5-12. BRAZING/DEBRAZING PROCEDURE. - Continued**NOTE**

If interconnecting tubing was removed with a component, braze tubing to the new components before installation.

- (3) Position component or assembly into place.

WARNING

Never use a heating torch on any part that contains refrigerant. Heat may cause the refrigerant to decompose and release irritating, toxic, and corrosive gases. All refrigerant must be discharged from the system and the entire system must be purged with dry nitrogen before beginning any brazing operation.

CAUTION

- If heat is applied slowly, or only on one side, the entire component or length of tubing will be heated and filler alloy in adjacent joints may also be melted.
- Brazing a joint without nitrogen flowing through the tubing, will cause deposits to form on the inside of the tube and may cause obstructions in the refrigeration system or equipment damage.

- (4) Check that the system is being purged (para 5-11) and apply sufficient heat uniformly around the joint to quickly melt the filler alloy. Remove heat and stop purging as soon as brazing is completed.

5-13. LEAK TESTING THE REFRIGERANT SYSTEM.

This task covers:**Testing**

INITIAL SETUP**Tools:**

Refrigeration Unit Service Tool Kit
4, Section III, Appendix B
Nitrogen Regulator
6, Section III, Appendix B

Materials/Parts:

Refrigerant R-134a
26, Appendix E
Nitrogen
22, Appendix E

Equipment Conditions:

Service manifold installed (para 5-9).

General Safety Instructions:**WARNING**

- Never pressurize refrigerant lines with oxygen, mixture with oil could cause an explosion.
- The pressure in a nitrogen cylinder can exceed 2000 psi. A nitrogen pressure regulator should be used at all times to avoid personal injury.
- Nitrogen is an inert gas that can cause suffocation and must be discharged in a well ventilated area.

Testing.**NOTE**

- **To perform leak test, it is necessary that the system be pressurized with a proportion of refrigerant gas.**
- **The electronic gas tester is highly sensitive to the presence of a minute quantity of gas in the air, and is quite effective in the detection of small leaks. However, due to rapid dispersion of refrigerant gas into surrounding air, difficulty may be encountered in pinpointing large leaks. The detector must be used in a well ventilated area but draft free area. Use procedures contained in TM 9-4940-435-14, "Leak Detector, Refrigerant Gas".**
 - (1) To pressurize a system that has some refrigerant charge.
 - (a) Connect the charge hose to a refrigerant cylinder containing refrigerant R-134a set to deliver gas only.
 - (b) Check that service manifold vacuum valve is closed.
 - (c) Open the service manifold compound gage, pressure gage, and charge valves.
 - (d) Open refrigerant cylinder valve and pressurize system to 100 psi (7.1 kg/cm²).

5-13. LEAK TESTING THE REFRIGERANT SYSTEM. - Continued

- (2) To pressurize a system that has been discharged and purged.
 - (a) Connect the charge hose to a refrigerant cylinder containing refrigerant R-134a set to deliver gas only.
 - (b) Check that service manifold vacuum valve is closed.
 - (c) Open the service manifold compound gage, pressure gage, and charge valves.
 - (d) Open refrigerant cylinder valve and pressurize system to 40-50 psi (2.8-3.5 kg/cm²).
 - (e) Close service manifold valves and refrigerant cylinder valve.
 - (f) Disconnect charge hose from the refrigerant cylinder and connect it to a nitrogen regulator and nitrogen cylinder.
 - (g) Open the service manifold compound gage, pressure gage, and charge valves.
 - (h) Open nitrogen cylinder valve and pressurize system to 350 psi (24.7 kg/cm²).
- (3) Test for leaks at all points of possible leakage using a refrigerant gas leak detector. If a leak is found, take necessary steps to replace damaged components or repair leak.
- (4) If no leak was found and refrigerant only was used to pressurize the system, check refrigeration unit charge (para 5-15).
- (5) If no leak was found and nitrogen was used to pressurize the system, discharge (para 5-10), evacuate (para 5-14), and charge (para 5-15) the refrigeration unit.

5-14. EVACUATING THE REFRIGERANT SYSTEM.

This task covers:

Evacuate

INITIAL SETUP

Tools:

Refrigeration Unit Service Tool Kit
4, Section III, Appendix B

Equipment Conditions:

Refrigerant system discharged (para 5-10).

Evacuate. The refrigeration system must be evacuated to remove all moisture and non-condensable before it is charged.

- (1) Check that new dehydrator was installed. If not, install one (para 5-17).
- (2) Check that service manifold charge valve is closed.
- (3) Connect the vacuum hose to vacuum pump and start pump.
- (4) Open service manifold high pressure gage, compound gage, and vacuum valves.
- (5) Run vacuum pump until at least 29 inches of mercury is measured on compound gage. Continue running vacuum pump for one more hour, while observing the compound gage. If gage needle moves back and forth, you have a leak which must be located and corrected (para 5-13).

NOTE

Inability to reach and hold 29 inches of mercury may indicate either a leak or a problem with the vacuum pump.

- (6) Close service manifold vacuum valve and stop vacuum pump. Note reading on compound gage and observe for 10 minutes. If pressure rises, moisture may still be in the system or a leak exists. If pressure rose, repeat evacuation and re-check. If the pressure rise occurs again at the same speed, a leak is in the system and must be found (para 5-13). If the pressure rise was slower the second time, moisture remains in the system and the evacuation process must be repeated until there is no rise.
- (7) Close service manifold high pressure gage and compound gage valves.
- (8) Disconnect the vacuum hose from vacuum pump.

5-14. EVACUATING THE REFRIGERANT SYSTEM. - Continued

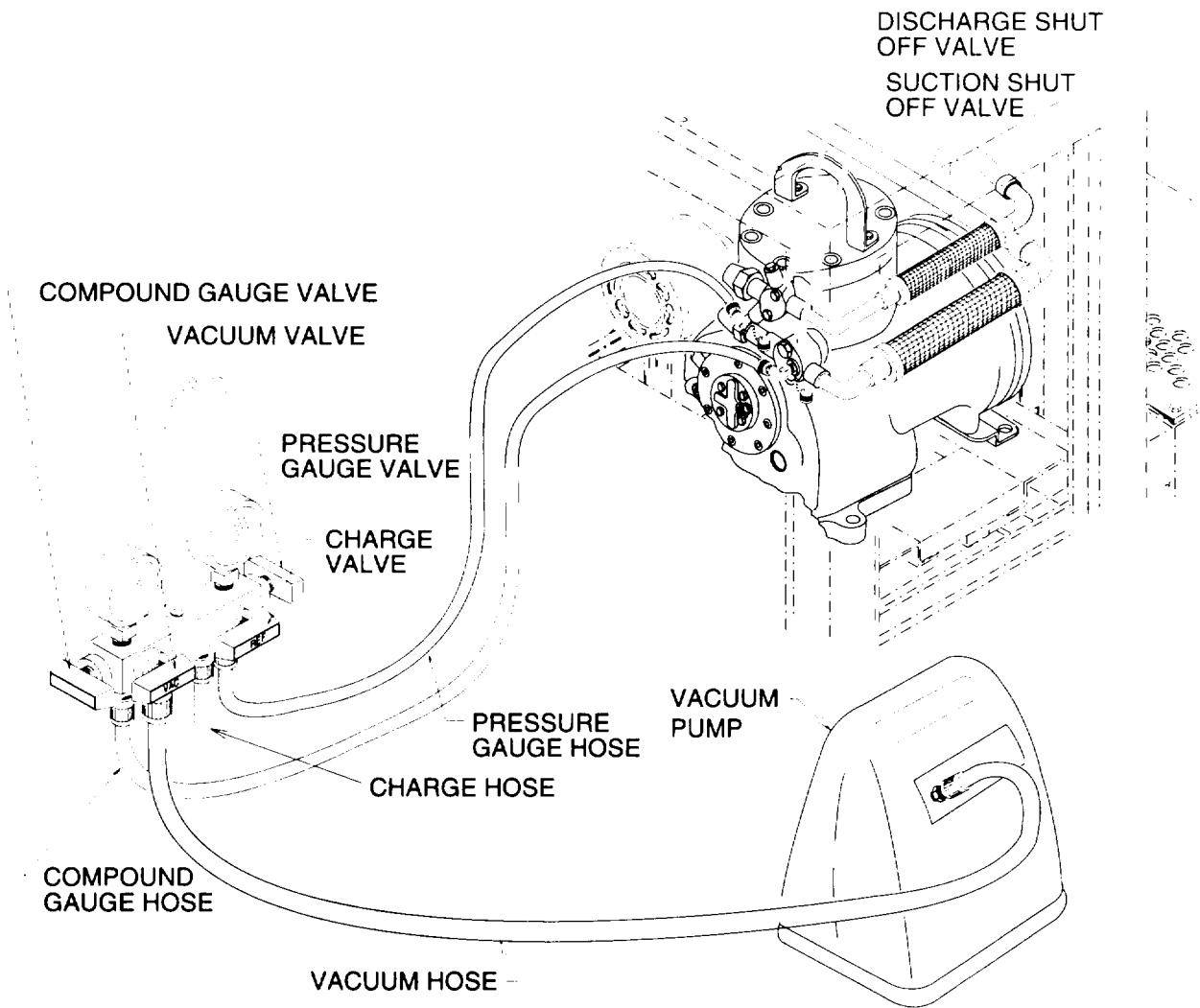

Figure 5-10. Evacuation of Refrigerant System

NOTE

FOLLOW-ON MAINTENANCE:
Charge the refrigeration system (para 5-15).

5-15. CHARGING THE REFRIGERANT SYSTEM.

This task covers:

a. Full Charge

b. Partial

c. Charge

INITIAL SETUPMaterials/Parts:

Refrigerant R-134a
26, Appendix E

Equipment Conditions:

Service manifold installed (para 5-9).
Refrigerant system evacuated (para 5-14).

General Safety Instructions:**WARNING**

Dangerous chemical refrigerant under pressure is used in the operation of this equipment. Use great care to avoid contact with liquid refrigerant.

General Safety Instructions:**WARNING**

- Sudden and irreversible tissue damage can result from freezing. Wear gloves and a face protector or safety glasses in any situation where skin or eye contact with refrigerant is possible.
 - Heat may cause the refrigerant to decompose and release irritating, toxic, and corrosive gases. Prevent contact of refrigerant with flame or hot surfaces.
 - Never introduce high discharge pressure into a refrigerant cylinder. This can cause the cylinder to rupture and injure personnel.
-

a. Full Charge.**CAUTION**

The system must be evacuated before charging. Moisture in the system will prevent the refrigeration unit from operating properly.

- (1) Connect the charge hose to a tank containing refrigerant R-134a set to deliver gas and the vacuum hose to reclaim unit.
- (2) Check that compound gage and pressure gage valves are closed.
- (3) Open vacuum and charge valves.
- (4) Open refrigerant tank valve. Operate reclaim unit for 3 to 5 seconds to purge hoses.
- (5) Close refrigerant tank, vacuum, and charge valves then stop reclaim unit.
- (6) Set refrigerant tank to deliver liquid only.
- (7) Place refrigerant tank on an accurate scale to measure and record weight.

5-15. CHARGING THE REFRIGERANT SYSTEM. - Continued**CAUTION**

Never introduce liquid refrigerant into the suction shut off valve. This can cause damage to the compressor.

- (8) Open refrigerant tank, pressure gage, and charge valves. Allow liquid refrigerant to enter system until tank weight has decreased by 10 pounds (4.5 kg) or until system pressure has equalized, whichever occurs first.
- (9) Close refrigerant tank, charge, and pressure gage valves.

NOTE

If 10 pounds (4.5 kg) full charge was obtained, skip steps (10) through (15).

- (10) Connect battery if disconnected (para 4-35).

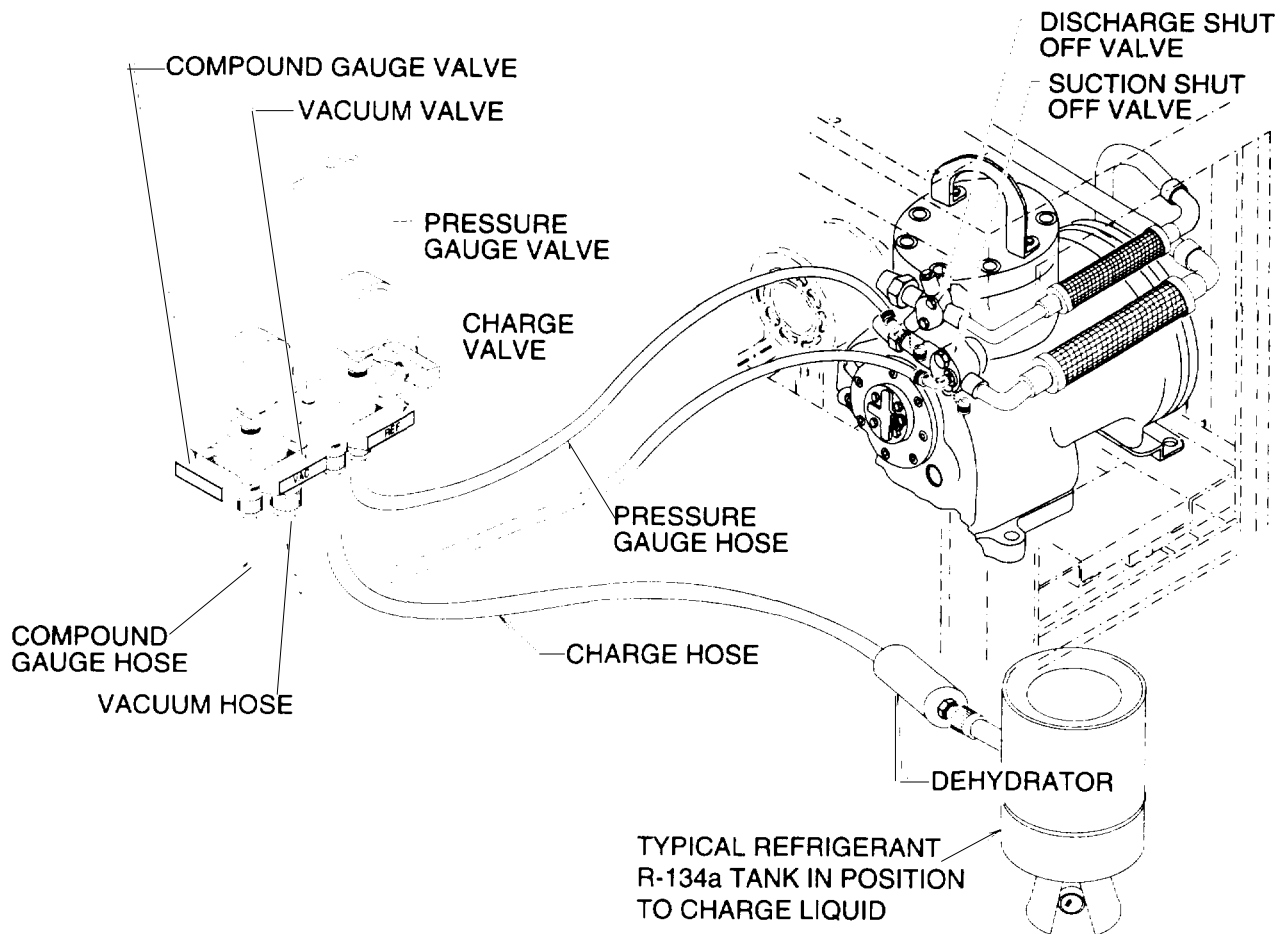

Figure 5-11. Refrigerant Charging (Total System)

WARNING

Engines have fast moving parts that can injure hands, fingers, etc. Take special care while in operation. Engine parts, particularly the exhaust system, can be very hot and cause severe burns.

- (11) Turn refrigeration unit on (para 2-5) and operate at desired temperature setting.
- (12) Set refrigerant tank to deliver gas only.
- (13) Check that all service manifold valves are closed.

WARNING

Never introduce high discharge pressure into a refrigerant tank. This can cause the tank to rupture and injure personnel.

CAUTION

Never introduce liquid refrigerant into the suction shut off valve. This can cause damage to the compressor.

- (14) Open refrigerant tank, compound gage, and charge valves.
- (15) Monitor weight of the refrigerant tank until total 10 pounds (4.5 kg) charge is obtained. When system is fully charged, immediately close refrigerant tank, compound gage, and charge valves.
- (16) Run refrigeration unit for 15 minutes and observe sight glass through left side door.
 - (a) Green or chartreuse center means refrigerant moisture content is acceptable.
 - (b) Yellow center means there is too much moisture in system. Discharge (para 5-10), replace dehydrator (para 5-17), leak check (para 5-13), evacuate (para 5-14), and charge again.
- (17) Be sure all service manifold valves are closed.
- (18) Shut off refrigeration unit (para 2-7).

b. **Partial Charge.**

- (1) Connect the charge hose to a tank containing refrigerant R-134a set to deliver gas and the vacuum hose to reclaim unit.
- (2) Check that compound gage and pressure gage valves are closed.
- (3) Open vacuum and charge valves.
- (4) Open refrigerant tank valve. Operate reclaim unit for 3 to 5 seconds to purge hoses.
- (5) Close refrigerant tank, vacuum, and charge valves then stop reclaim unit.
- (6) Connect battery (para 4-35).

5-15. CHARGING THE REFRIGERANT SYSTEM. - Continued

- (7) Turn refrigeration unit on (para 2-5) and operate at desired temperature setting.
- (8) Set refrigerant tank to deliver gas only.
- (9) Check that all service manifold valves are closed.

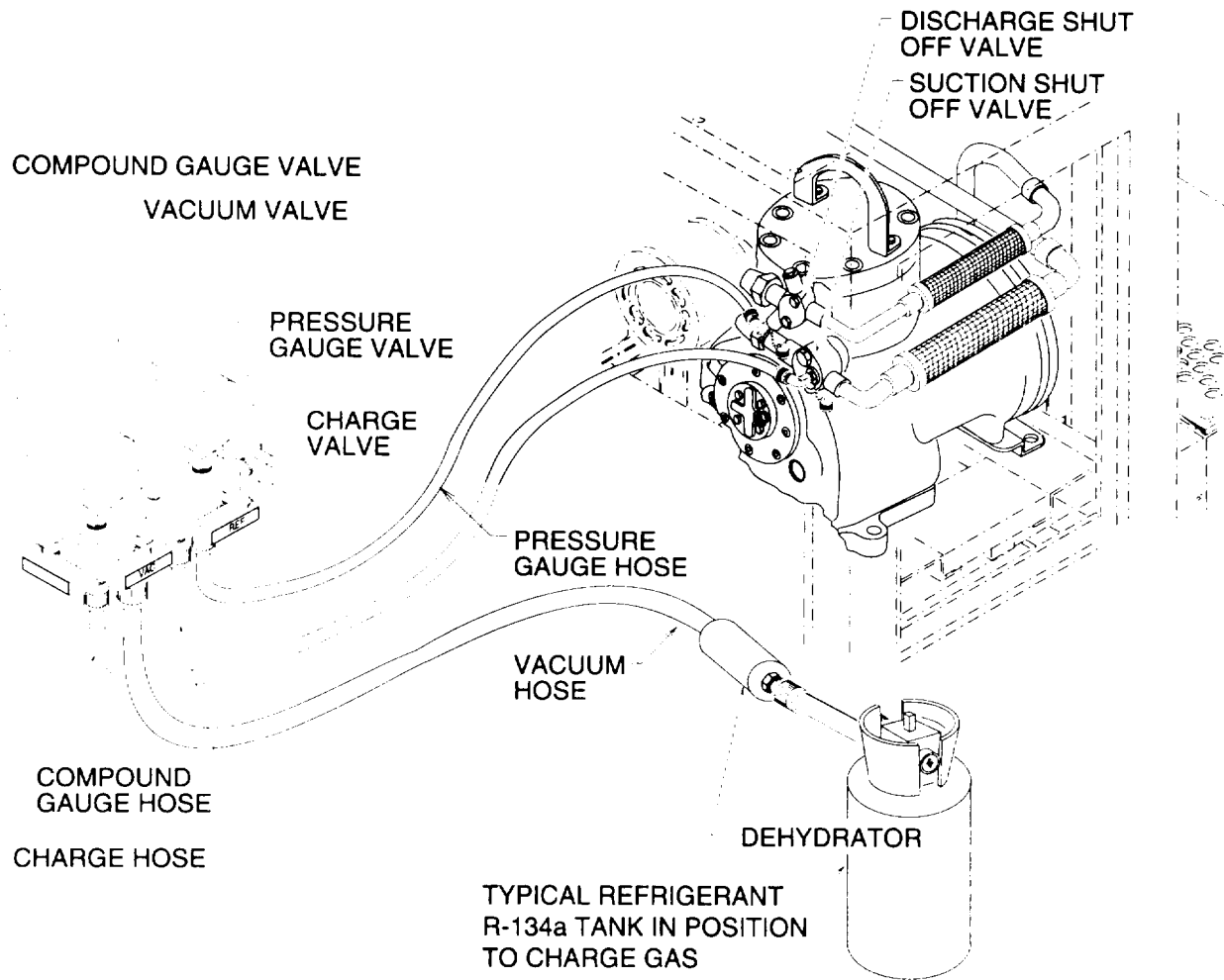

Figure 5-12. Refrigerant Charging (Partial System /Small Quantity Charge)

WARNING

Never introduce high discharge pressure into a refrigerant tank. This can cause the tank to rupture and injure personnel.

CAUTION

Never introduce liquid refrigerant into the suction shut off valve. This can cause damage to the compressor.

- (10) Open refrigerant tank, compound gage, and charge valves.
- (11) Run refrigeration unit for 15 minutes and observe sight glass through left side door.
 - (a) Green or chartreuse center means refrigerant moisture content is acceptable.
 - (b) Yellow center means there is too much moisture in system. Discharge (para 5-10), replace dehydrator (para 5-17), leak check (para 5-13), evacuate (para 5-14), and charge again.
 - (c) Milky white or bubbly liquid means system has low charge.
 - (d) Clean bubble free liquid around center means the system is fully charged.

CAUTION

Never introduce liquid refrigerant into the low pressure (suction) charging valve. This can cause damage to the compressor.

- (12) If charge is low, set refrigerant tank to deliver gas only.

WARNING

Never introduce high discharge pressure into a refrigerant cylinder. This can cause the cylinder to rupture and injure personnel.

- (13) Check that pressure gage valve is closed.
- (14) Open refrigerant tank, compound gage, and charge valves.
- (15) Charge until sight glass remains clear and bubble free for 15 minutes.
- (16) When system is fully charged, immediately close refrigerant tank, compound gage, and charge valves.
- (17) Shut off refrigeration unit (para 2-7).

NOTE

**FOLLOW-ON MAINTENANCE:
Remove service manifold (para 5-9).**

5-16. REFRIGERANT SYSTEM PRESSURE CHECK.

This task covers:

a. Testing

INITIAL SETUPEquipment Conditions:

Service manifold installed (para 5-9).

Testing.

- (1) Check that all four service manifold valves are closed.
- (2) Service manifold compound and pressure gages should indicate the same pressure. Check the reading with the appropriate column in Table 5-1. If the system is even partially charged, the pressure should be approximately equal to that shown in the table for the appropriate ambient temperature. If the pressure is considerably less than shown in the table, the system does not contain enough refrigerant to continue the pressure check. Leak test the refrigeration system (para 5-13).

Table 5-1. Pressure Temperature Relationship of Saturated Refrigerant R-134a

Temperature		Pressure	
Deg F	Deg C	psia	kg/cm ²
-20	-28.88	12.95	5.87
-18	-27.77	13.63	6.18
-16	-26.66	14.35	6.50
-14	-25.55	15.09	6.84
-12	-24.44	15.87	7.19
-10	-23.33	16.67	7.56
-8	-22.22	17.51	7.94
-6	-21.11	18.38	8.33
-4	-20.00	19.29	8.74
-2	-18.88	20.23	9.17
0	-17.77	21.20	9.61
2	-16.66	22.22	10.07
4	-15.55	23.27	10.55
6	-14.44	24.35	11.04
8	-13.33	25.48	11.55
10	-12.22	26.65	12.08
12	-11.11	27.86	12.63
14	-10.00	29.11	13.20
16	-8.88	30.41	13.79
18	-7.77	31.75	14.40
20	-6.66	33.14	15.03

Temperature		Pressure	
Deg F	Deg C	psia	kg/cm ²
60	15.55	72.09	32.69
62	16.66	74.69	33.87
64	17.77	77.36	35.08
66	18.88	80.09	36.32
68	20.00	82.90	37.60
70	21.11	85.79	38.91
72	22.22	88.75	40.25
74	23.33	91.79	41.63
76	24.44	94.90	43.04
78	25.55	98.09	44.49
80	26.66	101.37	45.98
82	27.77	104.73	47.50
84	28.88	108.16	49.06
86	30.00	111.69	50.66
88	31.11	115.30	52.16
90	32.22	118.99	53.97
92	33.33	122.78	55.69
94	34.44	126.65	57.44
96	35.55	130.62	59.24
98	36.66	134.68	61.08
100	37.77	138.83	62.59

Table 5-1. Pressure Temperature Relationship of Saturated Refrigerant R-134a - Continued

Temperature		Pressure	
Deg F	Deg C	psia	kg/cm ²
22	-5.55	34.57	15.68
24	-4.44	36.05	16.35
26	-3.33	37.58	16.78
28	-2.22	39.16	17.76
30	-1.11	40.79	18.50
32	-0	42.47	19.26
34	1.11	44.21	20.05
36	2.22	45.99	20.86
38	3.33	47.84	21.69
40	4.44	49.74	22.56
42	5.55	51.70	23.45
44	6.66	53.71	24.36
46	7.77	55.79	25.30
48	8.88	57.93	26.27
50	10.00	60.13	27.27
52	11.11	62.39	28.29
54	12.22	64.71	29.35
56	13.33	67.11	30.44
58	14.44	69.57	31.55
140	60.00	243.86	110.06
142	61.11	250.33	113.54
144	62.22	256.94	116.54
146	63.33	263.67	119.59
148	64.44	270.54	122.71
150	65.55	277.54	125.89

Temperature		Pressure	
Deg F	Deg C	psia	kg/cm ²
102	38.88	143.07	64.86
104	40.00	147.42	66.86
106	41.11	151.86	68.88
108	42.22	158.40	71.84
110	43.33	161.04	73.04
112	44.44	165.79	75.20
114	45.55	170.64	77.40
116	46.66	175.79	79.64
118	47.77	180.82	82.58
120	48.88	185.82	84.28
122	50.00	191.11	86.68
124	51.11	196.50	89.13
126	52.22	202.00	91.62
128	53.33	207.62	94.17
130	54.44	213.36	96.77
132	55.55	219.22	99.43
134	56.66	225.19	102.14
136	57.77	231.29	104.91
138	58.88	237.51	107.73
152	66.66	284.67	129.12
154	67.77	291.95	132.42
156	68.88	299.37	135.79
158	70.00	306.64	139.08
160	71.11	314.64	142.71

Table 5-2. Nominal Operating Pressure At Suction And Discharge Shut Off Valves

Air Temperature Entering Evaporator Coil	Air Temperature Entering Condenser Coil 110° F (43° C)
0° F (-18° C)	Suction 1 psi (7 kPa) Discharge 177 psi (1221 kPa)
35° F (2° C)	Suction 10 psi (69 kPa) Discharge 199 psi (1373 kPa)

5-16. REFRIGERANT SYSTEM PRESSURE CHECK. - Continued**WARNING**

Engines have fast moving parts that can injure hands, fingers, etc. Take special care while in operation. Engine parts, particularly the exhaust system, can be very hot and cause severe burns.

- (3) Turn the refrigeration unit on (para 2-5) and operate at desired setting.
- (4) With the refrigeration unit operating, allow service manifold gages to stabilize. Compare readings with those listed in Table 5-1.
 - (a) If discharge and suction pressure are at, or near, the same value, defrost solenoid valve (L2) or compressor (B1) failure is indicated.
 - (b) If discharge pressure is low and suction pressure is normal, a low refrigerant charge is indicated.
 - (c) If discharge pressure is normal and suction pressure is either high, or low, failure of the expansion valve is indicated.
 - (d) If discharge pressure is high and suction pressure is normal, refrigerant overcharge is indicated.
- (5) When pressure tests are completed, turn the refrigeration unit off (para 2-7) and disconnect battery.

NOTE

**FOLLOW-ON MAINTENANCE:
Remove service manifold (para 5-9).**

5-17. DEHYDRATOR REPLACEMENT.

This task covers:**a. Removal****b. Installation.**

INITIAL SETUPEquipment Conditions:

Refrigeration system discharged (para 5-10).
Left side door open.

a. Removal.

- (1) Loosen two flare nuts (1).

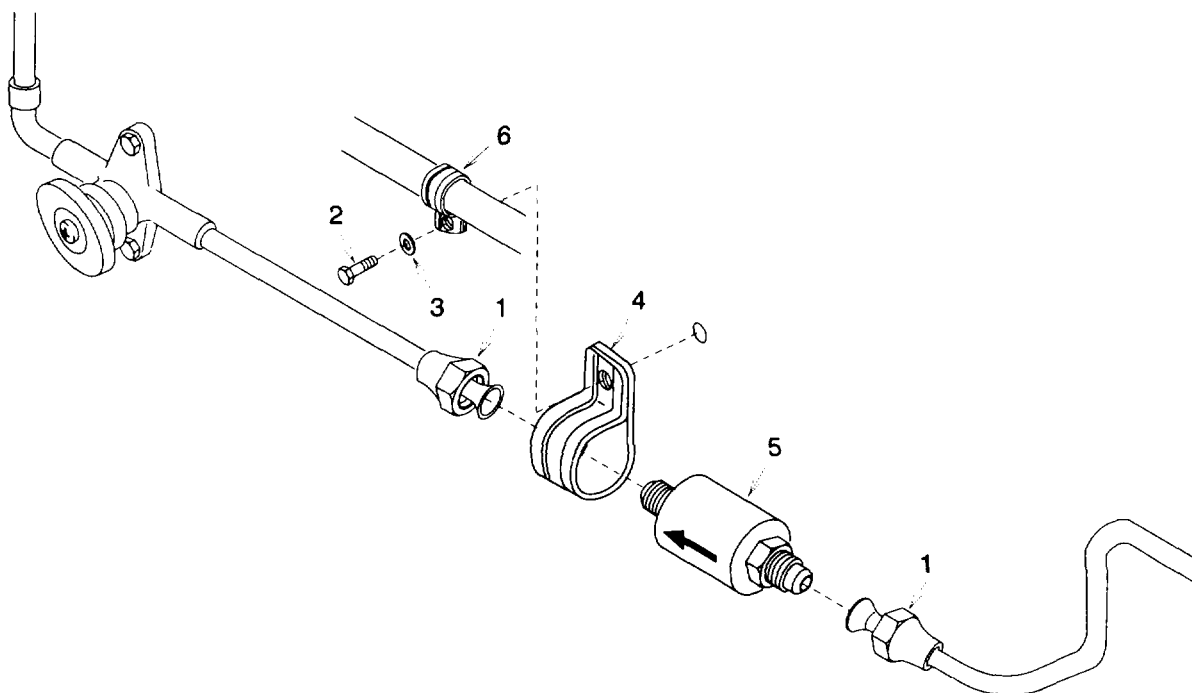

Figure 5-13. Dehydrator

NOTE

Note flow direction prior to removal.

- (2) Remove bolt (2), flat washer (3), clamp (4), and dehydrator (5).

5-17. DEHYDRATOR REPLACEMENT. - Continued

b. Installation.

NOTE

Do not remove dehydrator protective caps until just before installation. This will minimize the risk of contaminating the dehydrator. Be sure to observe flow direction noted during removal.

- (1) Install new dehydrator (5), clamp (4), clamp (6), flat washer (3), and bolt (2).
- (2) Tighten two flare nuts (1).

NOTE

FOLLOW-ON MAINTENANCE:

Leak check (para 5-13), evacuate (para 5-14), and charge (para 5-15) the refrigeration system. Close left side door.

5-18. COMPOUND GAGE REPLACEMENT.

This task covers:

a. Removal

b. Installation

INITIAL SETUP

Materials/Parts:

- Self Locking Nuts (3)
6, Appendix G
- Anti-Seize Tape
27, Appendix E
- Silicone RTV
1, Appendix E

Equipment Conditions:

- Refrigeration system discharged (para 5-10).
 - Left side door open.
-

a. Removal.

- (1) Loosen flare nut (1) and move copper tubing (2) over to one side being careful not to bend or kink tubing.
- (2) Remove coupling (3).
- (3) Remove three self locking nuts (4), bolts (5) and compound gage (6). Discard self locking nuts.

b. Installation.

- (1) Wrap anti-seize tape around compound gage (6) connector threads.
- (2) Install compound gage (6), three bolts (5), and new self locking nuts (4).
- (3) Install coupling (3).
- (4) Aline copper tubing (2) and connect flare nut (1) to coupling (3).
- (5) Seal any openings in back of compound gage (6) case with silicone RTV.

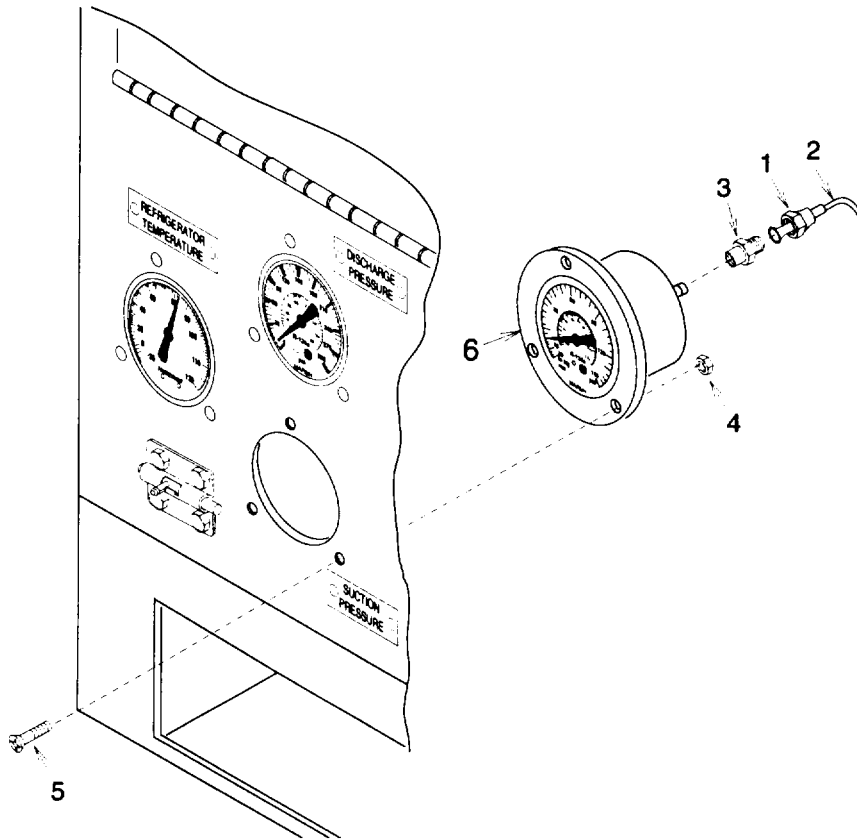

Figure 5-14. Compound Gage

NOTE**FOLLOW-ON MAINTENANCE:**

Replace dehydrator (para 5-17).

Leak check (para 5-13), evacuate (para 5-14), and charge (para 5-15) the refrigeration system.
Close left side door.

5-19. PRESSURE GAGE REPLACEMENT.

This task covers:**a. Removal****b. Installation**

INITIAL SETUPMaterials/Parts:

Self Locking Nuts (3)
6, Appendix G
Anti-Seize Tape
27, Appendix E
Silicone RTV
1, Appendix E

Equipment Conditions:

Refrigeration system discharged (para 5-10).
Left side door open.

a. Removal.

- (1) Loosen flare nut (1) and move copper tubing(2) over to one side being careful not to bend or kink tubing.
- (2) Remove coupling (3).
- (3) Remove three self locking nuts (4), bolts (5) and pressure gage (6). Discard self locking nuts.

b. Installation.

- (1) Wrap anti-seize tape around pressure gage (6) connector threads.
- (2) Install pressure gage (6), three bolts (5), and new self locking nuts (4).
- (3) Install coupling (3).
- (4) Aline copper tubing (2) and connect flare nut (1) to coupling (3).
- (5) Seal any openings in back of pressure gage (6)case with silicone RTV.

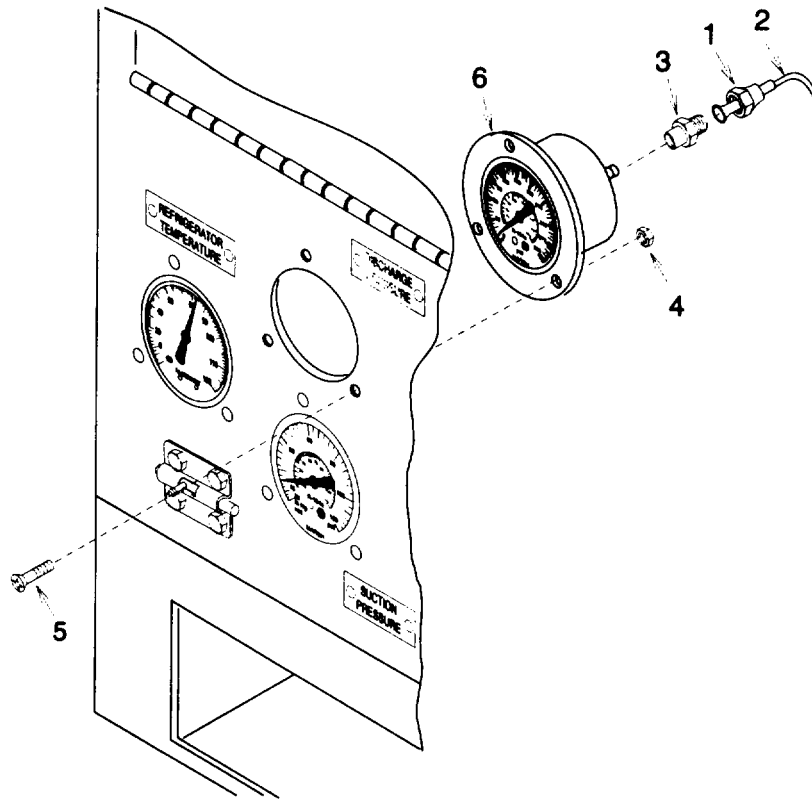

Figure 5-15. Pressure Gage

NOTE

FOLLOW-ON MAINTENANCE:

Replace dehydrator (para 5-17).

Leak check (para 5-13), evacuate (para 5-14), and charge (para 5-15) the refrigeration system.

Close left side door.

5-20. STRAINER REPLACEMENT.

This task covers:

a. Removal

b. Installation

INITIAL SETUPEquipment Conditions:

Refrigeration system discharged (para 5-10).
Left side door open.

NOTE

Note flow direction prior to removal.

- a. Removal. Loosen two flare nuts (1) and remove strainer (2).

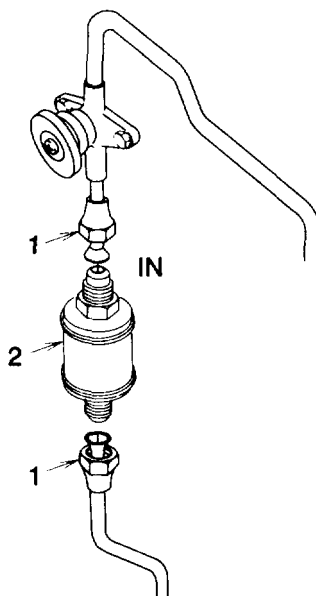

Figure 5-16. Strainer

NOTE

Be sure to observe flow direction noted during removal.

- b. Installation. Install strainer (2), tighten two flare nuts (1).

NOTE**FOLLOW-ON MAINTENANCE:**

Replace dehydrator (para 5-17).

Leak check (para 5-13), evacuate (para 5-14), and charge (para 5-15) the refrigeration system.

Close left side door.

5-21. ISOLATION VALVES REPLACEMENT.

This task covers:

a. Removal

b. Installation

INITIAL SETUP

Materials/Parts:

Teflon Seals (2)
28, Appendix G

Equipment Conditions:

Refrigeration system discharged (para 5-10).
Right side door open.

a. Removal.

- (1) Loosen two flare nuts (1) and move copper tubing (2) away from isolation valve (3) being careful not to bend or kink tubing.

NOTE

Isolation valve flare connections are different sizes. Note location prior to removal.

- (2) Remove two isolation valves (3) and teflon seals (4). Discard teflon seals.

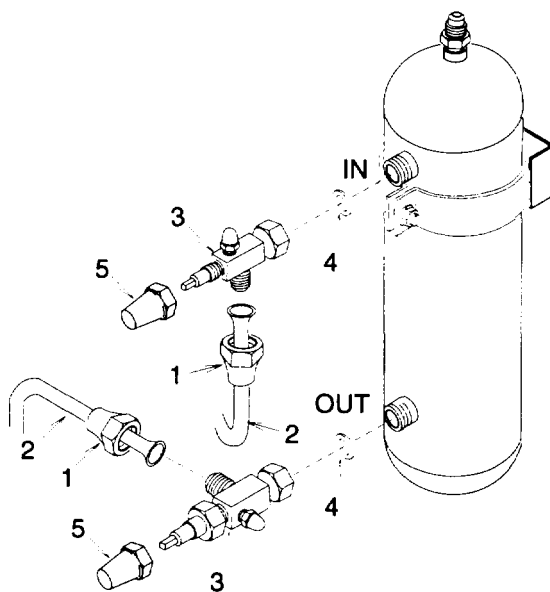

Figure 5-17. Isolation Valves

5-21. ISOLATION VALVES REPLACEMENT. - Continuedb. Installation.**NOTE**

Isolation valve flare connections are different sizes. Be sure to observe location noted during removal.

- (1) Install two new teflon seals (4) and isolation valves (3). Be sure valves are turned toward copper tubing (2) and tighten to between 50 and 60 ft lb (68 Nm and 82 Nm).
- (2) Aline copper tubing (2) and connect two flare nuts (1) to isolation valves (3).
- (3) Remove two isolation valve caps (5) and be sure isolation valves (3) are open. Install two isolation valve caps.

NOTE**FOLLOW-ON MAINTENANCE:**

Replace dehydrator (para 5-17).

Leak check (para 5-13), evacuate (para 5-14), and charge (para 5-15) the refrigeration system.

Close right side door.

5-22. RECEIVER REPLACEMENT.**This task covers:****a. Removal****b. Installation****INITIAL SETUP**Materials/Parts:

Self Locking Nut
29, Appendix G
Self Locking Nut
30, Appendix G
Lubricating Oil
28, Appendix E

Equipment Conditions:

Isolation valves removed (para 5-21).

General Safety Instructions:**WARNING**

Compressor lubricating oil used in this refrigeration system is caustic. Wear gloves and a face protector or safety glasses in any situation where skin or eye contact is possible. If oil does contact skin, wash with soap and water.

a. Removal.

- (1) Remove self locking nut (1), and flat washer (2). Discard self locking nut.

NOTE

Note flow direction prior to removal.

- (2) Remove self locking nut (3), flat washer (4), bolt (5), flat washer (6), and receiver (7). Discard self locking nut.
(3) Remove fusible plug (8).

b. Installation.

- (1) Lightly coat fusible plug (8) copper gasket with lubricating oil.
(2) Install fusible plug (8) and tighten to between 25 and 30 ft-lb (34 and 41 Nm).

NOTE

Be sure to observe flow direction noted during removal.

- (3) Install receiver (7), flat washer (6), bolt (5), flat washer (4), and new self locking nut (3).
(4) Install flat washer (2) and new self locking nut (1).

5-22. RECEIVER REPLACEMENT. - Continued

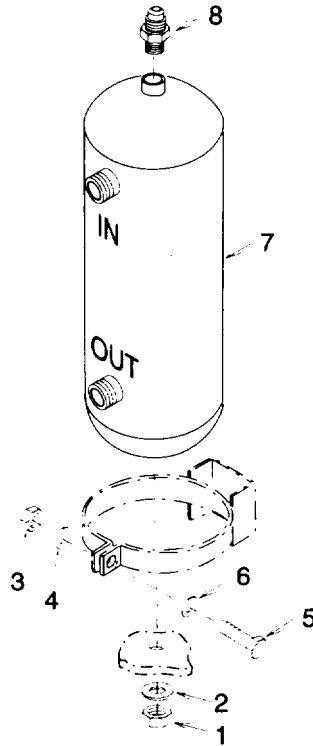

Figure 5-18. Receiver

NOTE

FOLLOW-ON MAINTENANCE:

Replace dehydrator (para 5-17).

Leak check (para 5-13), evacuate (para 5-14), and charge (para 5-15) the refrigeration system.

Close right side door.

5-23. CONDENSER COIL REPLACEMENT.

This task covers:

a. Removal

b. Installation

INITIAL SETUP

Materials/Parts:

- Self Locking Nuts (6)
7, Appendix G
- Lock Washers (2)
1, Appendix G
- Voltage regulator removed (para 4-57).

Equipment Conditions:

- Refrigeration system discharged (para 5-10) and purged (para 5-11).
- Both side doors open.
- Front coil guard panel removed (para 4-14).

a. Removal.

- (1) Remove bolts (1) and lock washers (2). Pull clamps (3) out of the way and discard lock washers.
- (2) Purge (para 5-11) and de-braze (para 5-12) two fittings (4) from condenser coil (5).

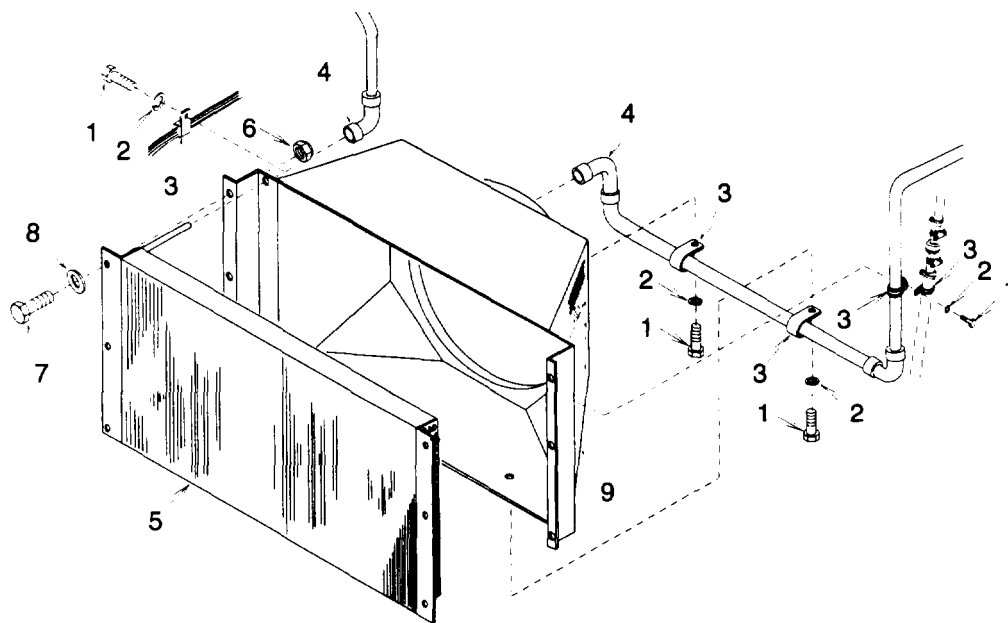

Figure 5-19. Condenser Coil

5-23. CONDENSER COIL REPLACEMENT. - Continued**WARNING**

Coil fins are sharp and can cut hands or fingers. Wear gloves to prevent personal injury when handling coil.

- (3) Remove six self locking nuts (6), bolts (7), flat washers (8), condenser coil (5), and condenser shroud (9). Discard self locking nuts.

b. Installation.**WARNING**

Coil fins are sharp and can cut hands or fingers. Wear gloves to prevent personal injury when handling coil.

- (1) Install condenser shroud (9), condenser coil (5), six flat washers (8), bolts (7), and new self locking nuts (6).
- (2) Purge (para 5-11) and braze (para 5-12) two fittings (4) onto condenser coil (5).
- (3) Aline clamps (3) then install flat washer (2) and bolt (1).

NOTE**FOLLOW-ON MAINTENANCE:**

Install condenser coil guard (para 4-14).

Replace dehydrator (para 5-17).

Leak check (para 5-13), evacuate (para 5-14), and charge (para 5-15) the refrigeration system.

Close both side doors.

5-24. PRESSURE REGULATOR VALVE (DISCHARGE) REPLACEMENT.

This task covers:**a. Removal****b. Installation**

INITIAL SETUPMaterials/Parts:Lock Washer
1, Appendix GEquipment Conditions:Refrigeration system discharged (para 5-10) and
purged (para 5-11).
Left side door open.**a. Removal.**

- (1) Remove bolt (1), lock washer (2), and clamp (3). Discard lock washer.
- (2) Purge (para 5-11) and de-braze (para 5-12) two fittings (4) and bushings (5). Remove pressure regulator valve (6).

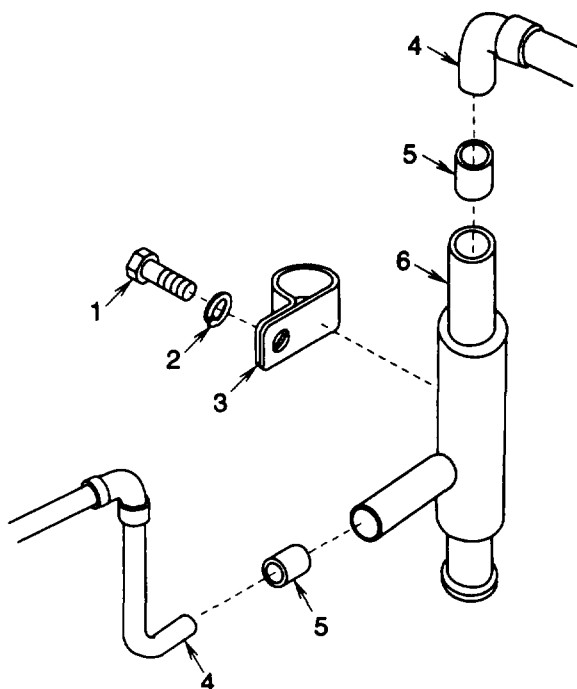
**Figure 5-20. Pressure Regulator Valve**

5-24. PRESSURE REGULATOR VALVE (DISCHARGE) REPLACEMENT. - Continued

b. Installation.

- (1) Purge (para 5-11) and braze (para 5-12) two fittings (4) and bushings (5) onto pressure regulator valve (6).
- (2) Install clamp (3) onto pressure regulator valve (6) and align clamp. Install new lock washer (2) and bolt (1).

NOTE

FOLLOW-ON MAINTENANCE:

Replace dehydrator (para 5-17).

Leak check (para 5-13), evacuate (para 5-14), and charge (para 5-15) the refrigeration system.

Close left side door.

5-25. PRESSURE REGULATOR VALVE (CRANKCASE) REPLACEMENT.

This task covers:

a. Removal

b. Installation

INITIAL SETUP

Materials/Parts:

Insulation Tape
6, Appendix E
Lock Washer
1, Appendix G

Equipment Conditions:

Refrigeration system discharged (para 5-10) and
purged (para 5-11).
Left side door open.

a. Removal.

- (1) Remove insulation (1).
- (2) Remove bolt (2), lock washer (3), and clamp (4). Discard lock washer.
- (3) Purge (para 5-11) and de-braze (para 5-12) two fittings (5). Remove pressure regulator valve (6).

b. Installation.

- (1) Purge (para 5-11) and braze (para 5-12) two fittings (5) onto pressure regulator valve (6).
- (2) Install clamp (4) onto pressure regulator valve (6) and align clamp. Install new lock washer (3) and bolt (2)
- (3) Install insulation (1) and secure with insulation tape as necessary.

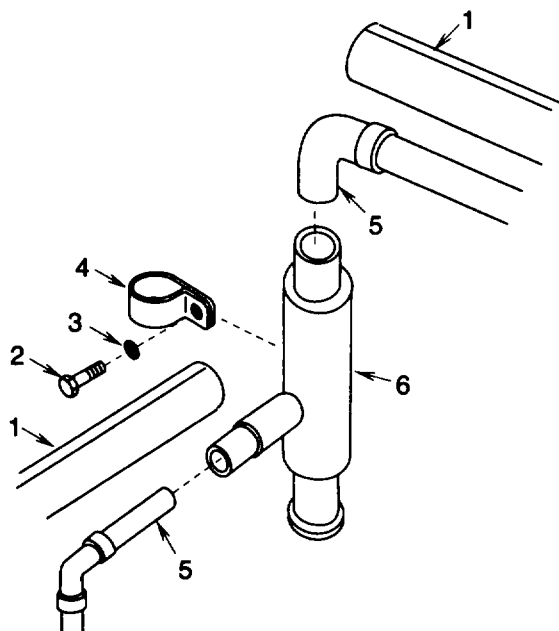

Figure 5-21. Pressure Regulator Valve

NOTE

FOLLOW-ON MAINTENANCE:

Replace dehydrator (para 5-17).

Leak check (para 5-13), evacuate (para 5-14), and charge (para 5-15) the refrigeration system.

Close left side door.

5-26. CHECK VALVE REPLACEMENT.

This task covers:**a. Removal****b. Installation**

INITIAL SETUPMaterials/Parts:Lock Washer
1, Appendix GEquipment Conditions:Refrigeration system discharged (para 5-10) and
purged (para 5-11).
Engine removed (para 4-61).

a. Removal.

- (1) Remove bolt (1), lock washer (2), clamp (3), and spacer (4). Discard lock washer.
- (2) Purge (para 5-11) and de-braze (para 5-12) two fittings(5) from check valve (6).

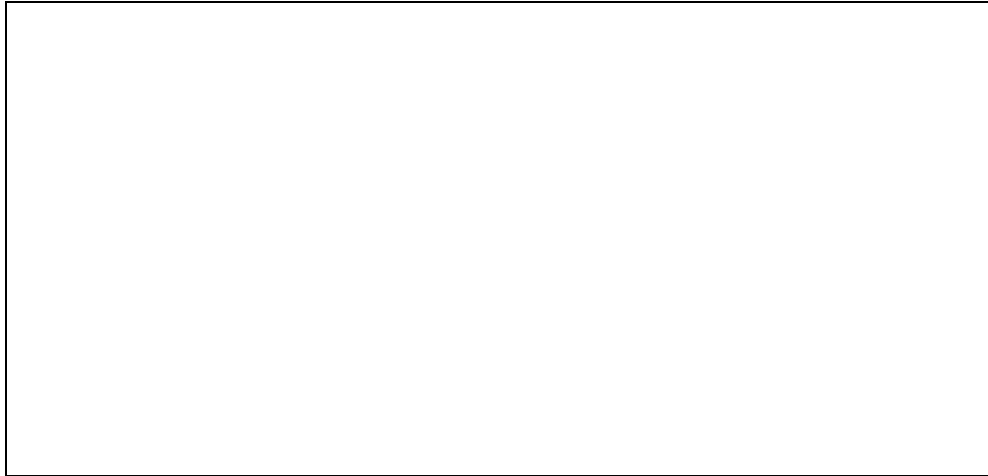
**Figure 5-22. Check Valve****b. Installation.**

- (1) Purge (para 5-11) and braze (para 5-12) two fittings (5) onto check valve (6).
- (2) Install spacer (4), clamp (3), new lock washer (2), and bolt (1).

NOTE**FOLLOW-ON MAINTENANCE:**

Replace dehydrator (para 5-17).

Leak check (para 5-13), evacuate (para 5-14), and charge (para 5-15) the refrigeration system.

Install Engine (para 4-61).

5-27. METAL HOSE ASSEMBLY (DISCHARGE) REPLACEMENT.

This task covers:

a. Removal

b. Installation

INITIAL SETUPEquipment Conditions:

Refrigeration system discharged (para 5-10) and
 purged (para 5-11).
 Right side door open.

- a. Removal. Purge (para 5-11) and de-braze (para 5-12) two fittings (1) and bushing (2). Remove metal hose assembly (3).

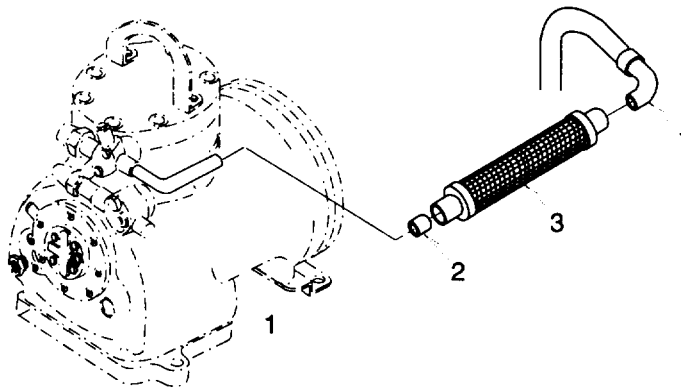

Figure 5-23. Metal Hose Assembly

- b. Installation. Install metal hose assembly (3) then purge (para 5-11) and braze (para 5-12) bushing (2) and two fittings (1).

NOTE**FOLLOW-ON MAINTENANCE:**

Replace dehydrator (para 5-17).

Leak check (para 5-13), evacuate (para 5-14), and charge (para 5-15) the refrigeration system.

Close right side door.

5-28. METAL HOSE ASSEMBLY (SUCTION) REPLACEMENT .**This task covers:****a. Removal****b. Installation****INITIAL SETUP**Materials/Parts:Insulation Tape
6, Appendix EEquipment Conditions:Refrigeration system discharged (para 5-10) and
purged (para 5-11).
Right side door open.**a. Removal.**

- (1) Remove insulation (1) as necessary.
- (2) Purge (para 5-11) and de-braze (para 5-12) two fittings (2) and remove metal hose assembly (3).

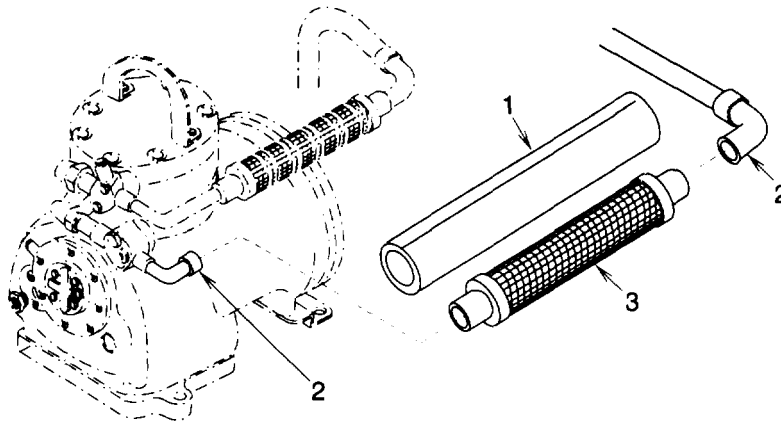
**Figure 5-24. Metal Hose Assembly****b. Installation.**

- (1) Install metal hose assembly (3) then purge (para 5-11) and braze (para 5-12) two fittings (2).
- (2) Install insulation (1) and secure with insulation tape as necessary.

NOTE**FOLLOW-ON MAINTENANCE:**

Replace dehydrator (para 5-17).

Leak check (para 5-13), evacuate (para 5-14), and charge (para 5-15) the refrigeration system.

Close right side door.

5-29. ACCUMULATOR REPLACEMENT.

This task covers:**a. Removal****b. Installation**

INITIAL SETUPMaterials/Parts:

Self Locking Nut
7, Appendix G
Self Locking Nut
30, Appendix G
Insulation Tape
6, Appendix E

Equipment Conditions:

Refrigeration system discharged (para 5-10) and
purged (para 5-11).
Left side door open.

a. Removal.

- (1) Remove insulation (1) as necessary.

NOTE**Note flow direction prior to debrazing fittings.**

- (2) Purge (para 5-11), de-braze (para 5-12), and separate two fittings (2).
- (3) Remove self locking nut (3), and flat washer (4). Discard self locking nut.
- (4) Remove self locking nut (5), flat washer (6), bolt (7), flat washer (8), and accumulator (9).
- (5) Purge (para 5-11), de-braze (para 5-12), and remove tube (10).

b. Installation.

- (1) Purge (para 5-11) and braze (para 5-12) tube (10) onto accumulator (9) outlet.
- (2) Install accumulator (9), flat washer (8), bolt (7), flat washer (6), and new self locking nut (5).
- (3) Install flat washer (4) and new self locking nut (3).

NOTE**Be sure to observe flow direction noted prior to debrazing.**

- (4) Purge (para 5-11) and braze (para 5-12) two fittings (2) onto accumulator (9).
- (5) Install insulation (1) and secure with insulation tape as necessary.

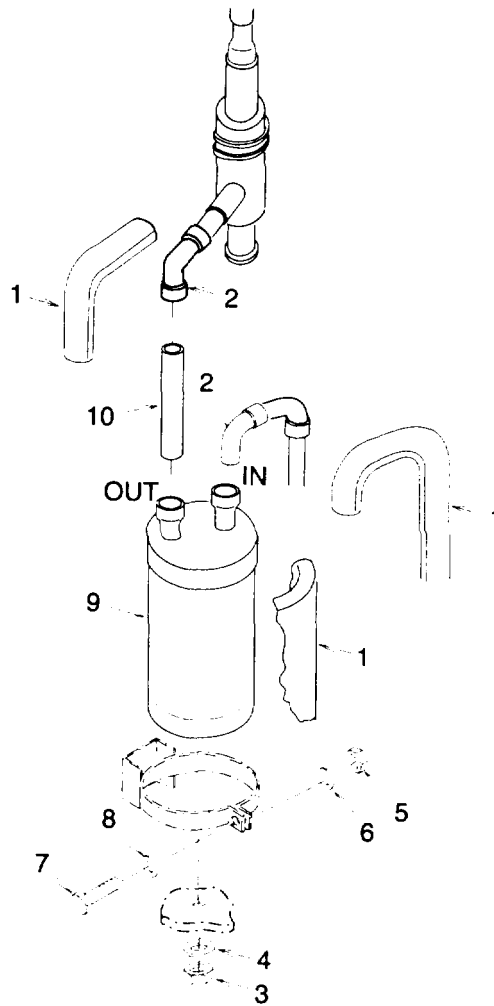

Figure 5-25. Accumulator

NOTE

FOLLOW-ON MAINTENANCE:

Replace dehydrator (para 5-17).

Leak check (para 5-13), evacuate (para 5-14), and charge (para 5-15) the refrigeration system.

Close left side door.

5-30. SOLENOID VALVE L1 (LIQUID LINE) REPLACEMENT.

This task covers:

a. Removal

b. Installation

INITIAL SETUPMaterials/Parts:

Marker tags (2)
4, Appendix E
Lock Washers (2)
32, Appendix G

Equipment Conditions:

Refrigeration system discharged (para 5-10).
Left side door open.
Accumulator removed (para 5-29).

a. Removal.

- (1) Tag and disconnect wire leads (1).

NOTE

Solenoid coil mounting hardware is supplied with solenoid valve.

- (2) Remove screw (2), lock washer (3), data plate (4), and solenoid valve coil (5).

NOTE

Note flow direction prior to removal.

- (3) Loosen two flare nuts (6) then remove two bolts (7), lock washers (8), and solenoid valve (9). Discard lock washers.

b. Installation.**NOTE**

Be sure to observe flow direction noted during removal.

- (1) Install solenoid valve (9), two new lock washers (8), and bolts (7). Tighten two flare nuts (6).
- (2) Install solenoid valve coil (5), data plate (4), lock washer (3), and screw (2).
- (3) Using tags and wiring diagram (fig. 2-4), connect wire leads (1). Remove tags.

5-30. SOLENOID VALVE L1 (LIQUID LINE) REPLACEMENT. - Continued

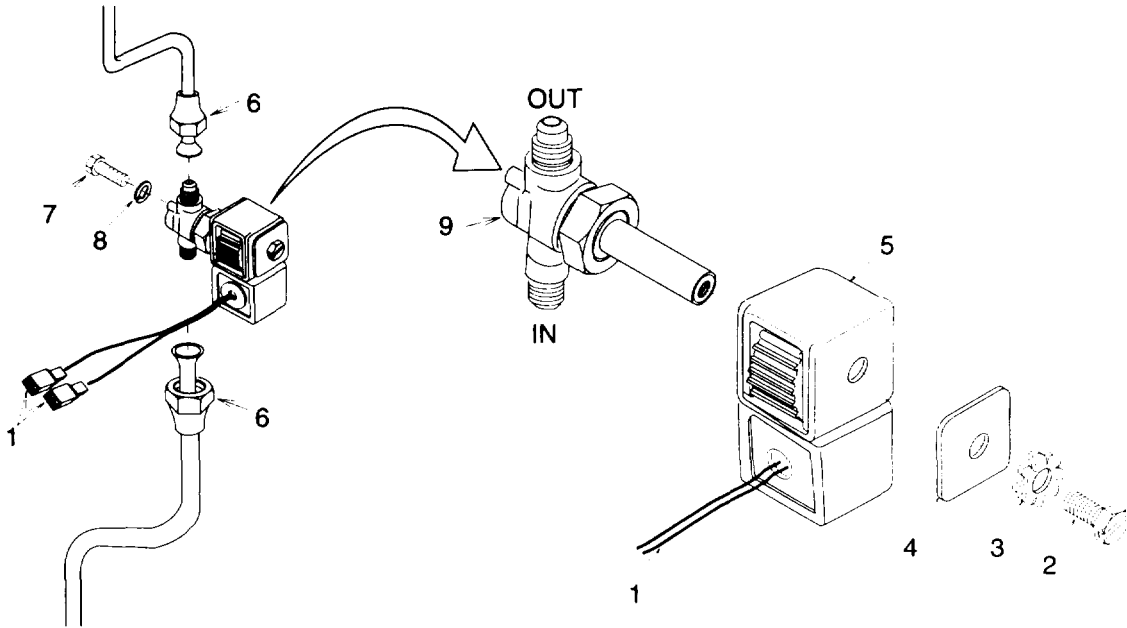

Figure 5-26. Solenoid Valve (Liquid Line)

NOTE

FOLLOW-ON MAINTENANCE:
Replace dehydrator (para 5-17).
Install accumulator (para 5-29).

Leak check (para 5-13), evacuate (para 5-14), and charge (para 5-15) the refrigeration system.
Close left side door.

5-31. SOLENOID VALVE L2 (DEFROST LINE) REPLACEMENT.

This task covers:

- a. Pre-Inspection
- b. Removal
- c. Cleaning.

INITIAL SETUP

Materials/Parts:

Marker tags (2)
4, Appendix E

Equipment Conditions:

Refrigeration system discharged (para 5-10).
Left side door open.

a. Removal.

- (1) Tag and disconnect wire leads (1).

NOTE

Solenoid coil mounting hardware is supplied with solenoid valve.

- (2) Remove screw (2), lock washer (3), data plate (4), and solenoid valve coil (5).

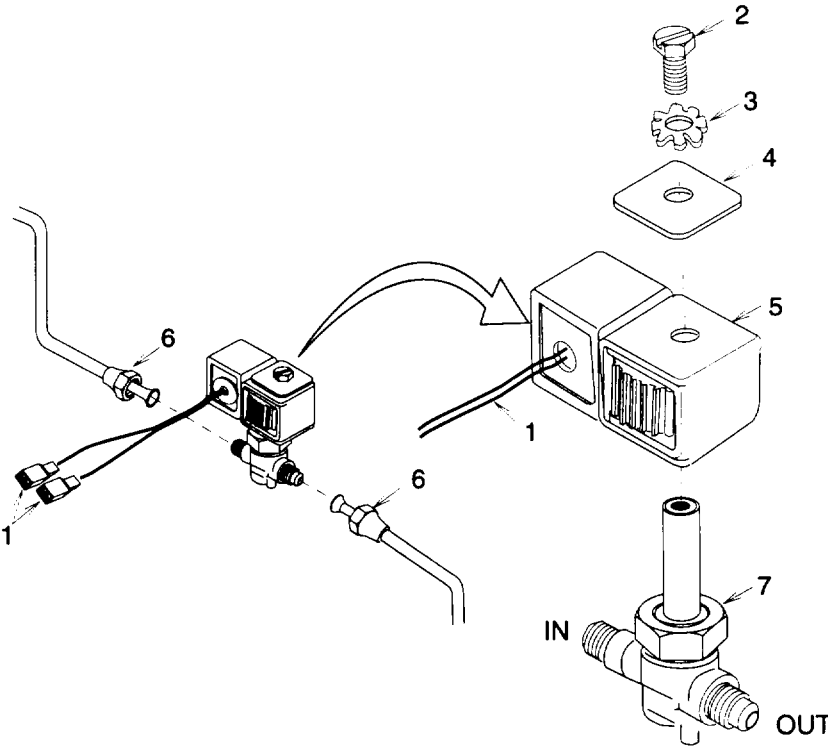

Figure 5-27. Solenoid Valve (Defrost Line)
5-55

5-31. SOLENOID VALVE L2 (DEFROST LINE) REPLACEMENT. - Continued**NOTE**

Note flow direction prior to removal.

- (3) Loosen two flare nuts (6) and remove solenoid valve (7).

b. Installation.

NOTE

Be sure to observe flow direction noted during removal.

- (1) Install solenoid valve (7) and tighten two flare nuts (6).
- (2) Install solenoid valve coil (5), data plate (4), lock washer (3), and screw (2).
- (3) Using tags and wiring diagram (fig. 2-4), connect wire leads (1). Remove tags.

NOTE**FOLLOW-ON MAINTENANCE:**

Replace dehydrator (para 5-17).

Leak check (para 5-13), evacuate (para 5-14), and charge (para 5-15) the refrigeration system.

Close left side door.

5-32. STOP VALVE (LIQUID LINE) REPLACEMENT.

This task covers:**a. Removal****b. Installation**

INITIAL SETUPMaterials/Parts:Lock Washers (2)
1, Appendix GEquipment Conditions:Refrigeration system discharged (para 5-10) and
purged (para 5-11).
Left side door open.**a. Removal.**

- (1) Purge (para 5-11) and de-braze (para 5-12) two fittings (1) from stop valve (2).
- (2) Remove two bolts (3), lock washer (4), and stop valve (2). Discard lock washers.

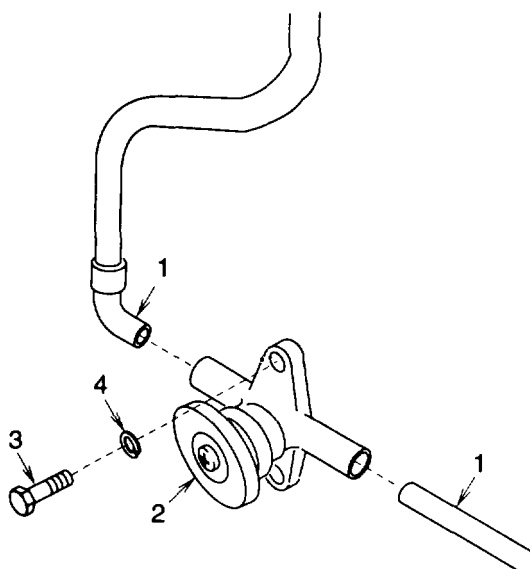
**Figure 5-28. Stop Valve**

5-32. STOP VALVE (LIQUID LINE) REPLACEMENT. - Continued

b. Installation.

- (1) Install stop valve (2), two new lock washers (4) and bolts (3).
- (2) Purge (para 5-11) and braze (para 5-12) two fittings (1) onto stop valve (2).

NOTE

FOLLOW-ON MAINTENANCE:

Replace dehydrator (para 5-17).

Leak check (para 5-13), evacuate (para 5-14), and charge (para 5-15) the refrigeration system.

Close left side door.

5-33. STOP VALVE (DEFROST LINE) REPLACEMENT.

This task covers:

a. Removal

b. Installation

INITIAL SETUP

Materials/Parts:

Lock Washers (2)
1, Appendix G

Equipment Conditions:

Refrigeration system discharged (para 5-10) and
purged (para 5-11).
Left side door open.

a. Removal.

- (1) Purge (para 5-11) and de-braze (para 5-12) two fittings (1) from stop valve (2).
- (2) Remove two bolts (3), lock washers (4), and stop valve (2). Discard lock washers.

b. Installation.

- (1) Install stop valve (2), two new lock washers (4) and bolts (3).
- (2) Purge (para 5-11) and braze (para 5-12) two fittings (1) onto stop valve (2).

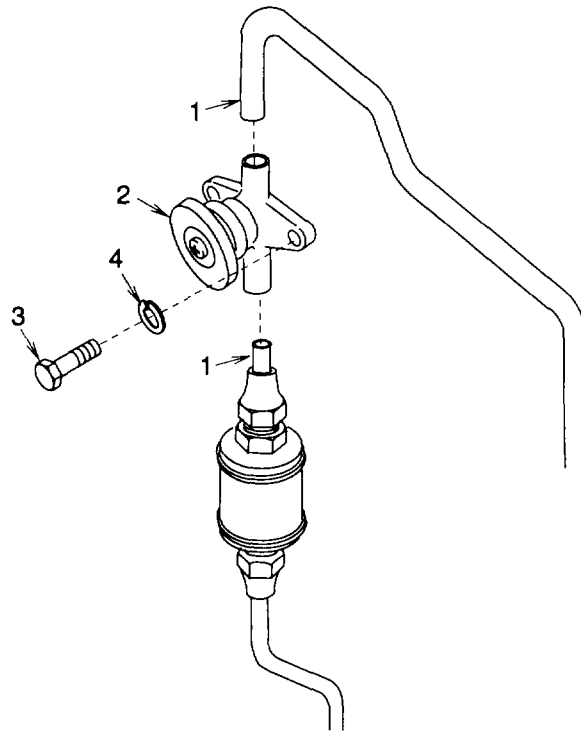

Figure 5-29. Stop Valve

NOTE

FOLLOW-ON MAINTENANCE:

Replace dehydrator (para 5-17).

Leak check (para 5-13), evacuate (para 5-14), and charge (para 5-15) the refrigeration system.

Close left side door.

5-34. SIGHT INDICATOR REPLACEMENT.**This task covers:****a. Removal****b. Installation****INITIAL SETUP**Materials/Parts:Self Locking Nuts (2)
4, Appendix GEquipment Conditions:Refrigeration system discharged (para 5-10).
Left side door open.**a. Removal.**

- (1) Remove two self locking nuts (1), screws (2), spacers (3), and clamps (4).
- (2) Loosen two flare nuts (5) and remove sight indicator (6).

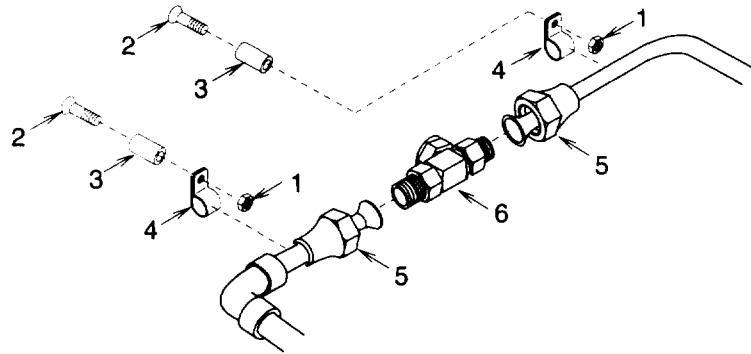
**Figure 5-30. Sight Indicator****b. Installation.**

- (1) Install sight indicator (6), aligned facing the side door, and tighten two flare nuts (5).
- (2) Install two clamps (4), screws (2), spacers (3), and new self locking nuts (1).

NOTE**FOLLOW-ON MAINTENANCE:**

Replace dehydrator (para 5-17).

Leak check (para 5-13), evacuate (para 5-14), and charge (para 5-15) the refrigeration system.

Close left side door.

5-35. DIFFERENTIAL OIL PRESSURE SWITCH S5 REPLACEMENT.**This task covers:****a. Removal****b. Installation****INITIAL SETUP**Materials/Parts:

Marker tags (4)
4, Appendix E
Tie Down Strap
5, Appendix E
Lock Washers (2)
1, Appendix G

Equipment Conditions:

Refrigeration system discharged (para 5-10).
Left side door open.
Battery removed (para 4-35).

a. Removal.

- (1) Loosen screw (1) and remove cover (2).

NOTE

Terminal hardware is supplied with oil pressure switch.

- (2) Tag wire leads (3). Remove four screws (4) and pull leads out of differential oil pressure switch (5).
- (3) Remove tie down strap (6).
- (4) Tag capillary tubes (7) and loosen two flare nuts (8). Move capillary tubes to the side being careful not to kink or bend tubing.
- (5) Remove two bolts (9), lock washers (10), flat washers (11), and differential oil pressure switch (5). Remove grommet (12). Discard lock washers.

b. Installation.

- (1) Loosen screw (1) and remove cover (2) from new differential oil pressure switch (5).
- (2) Install grommet (12) into bottom of differential oil pressure switch (5).
- (3) Install differential oil pressure switch (5), two flat washers (11), new lock washers (10), and bolts (9).
- (4) Using tags on old differential oil pressure switch (5) for reference, align capillary tubes (7) and tighten two flare nuts (8). Secure capillary tube with tie down strap (6) as shown.

5-35. DIFFERENTIAL OIL PRESSURE SWITCH S5 REPLACEMENT . - Continued

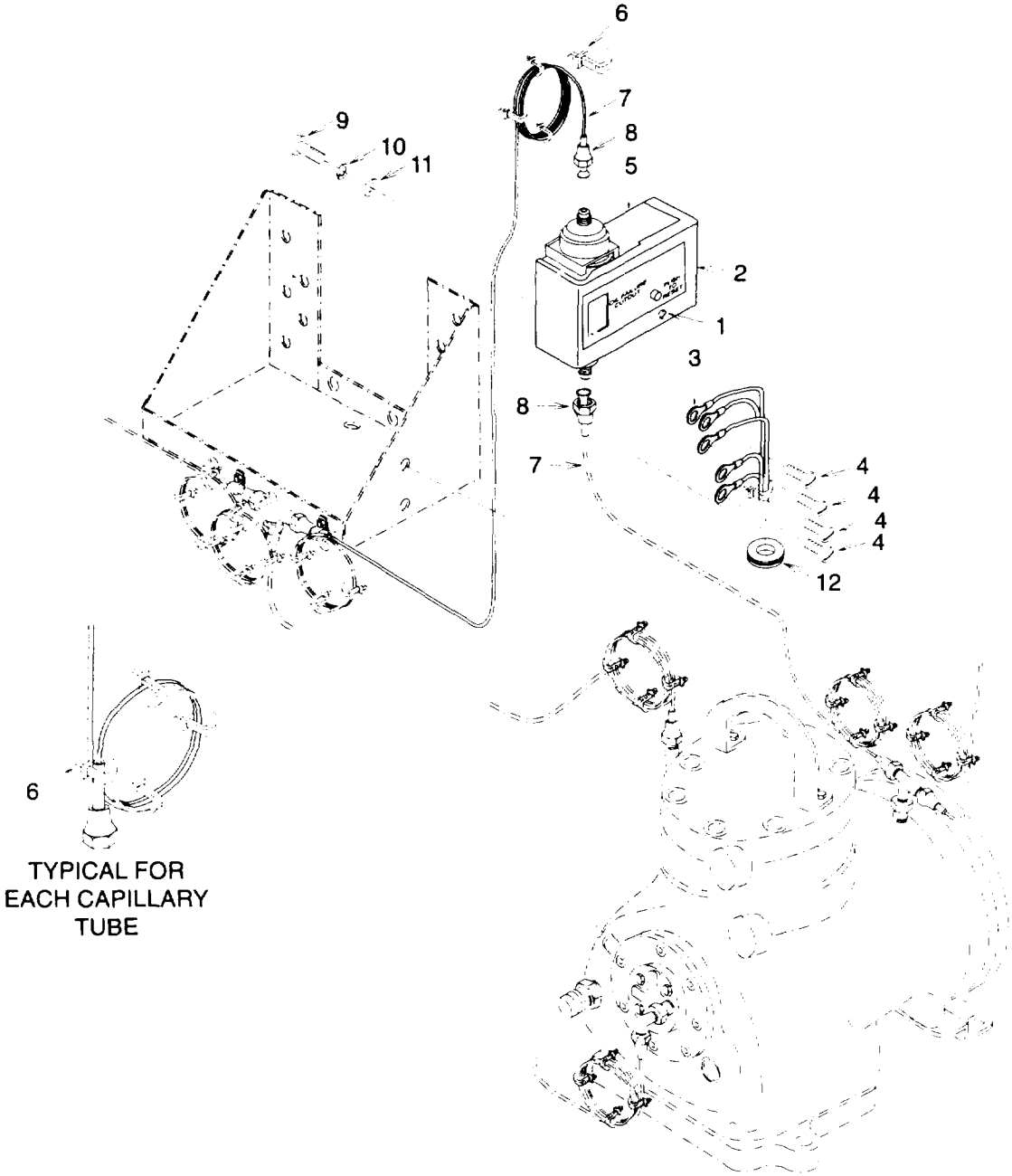

Figure 5-31. Differential Oil Pressure Switch

- (5) Push leads (3) through grommet (12) in differential oil pressure switch (5). Using tags and wiring diagram (fig. 2-4) install wire leads and secure with four screws (4). Remove tags.
- (6) Install cover (2) and tighten screw (1).

NOTE

FOLLOW-ON MAINTENANCE:
Install battery (para 4-35).
Replace dehydrator (para 5-17).
Leak check (para 5-13), evacuate (para 5-14), and charge (para 5-15) the refrigeration system.
Close right side door.

5-36. DUAL PRESSURE CONTROL SWITCH S2 REPLACEMENT.

This task covers:

a. Removal

b. Installation

INITIAL SETUP

Materials/Parts:

Self Locking Nuts (2)
 4, Appendix G
 Marker tags (3)
 4, Appendix E
 Tie Down Straps (2)
 5, Appendix E

Materials/Parts:

Lock Washers (2)
 1, Appendix G

Equipment Conditions:

Refrigeration system discharged (para 5-10).
 Right side door open.
 Battery removed (para 4-35).

a. Removal.

- (1) Loosen screw (1) and remove cover (2).
- (2) Tag wire leads (3). Remove two screws (4) and pull leads out of dual pressure control switch (5).
- (3) Remove two self locking nuts (6), bolts (7) and clamps (8). Discard self locking nuts.
- (4) Remove two tie down straps (9).
- (5) Tag each capillary tube (10) and loosen two flare nuts (11).
- (6) Remove two bolts (12), lock washers (13), and dual pressure control switch (5). Discard lock washers. Remove grommet (14).

b. Installation.

- (1) Loosen screw (1) and remove cover (2) from new dual pressure control switch (5).
- (2) Install grommet (14) into bottom of dual pressure control switch (5).

5-36. DUAL PRESSURE CONTROL SWITCH S2 REPLACEMENT. - Continued

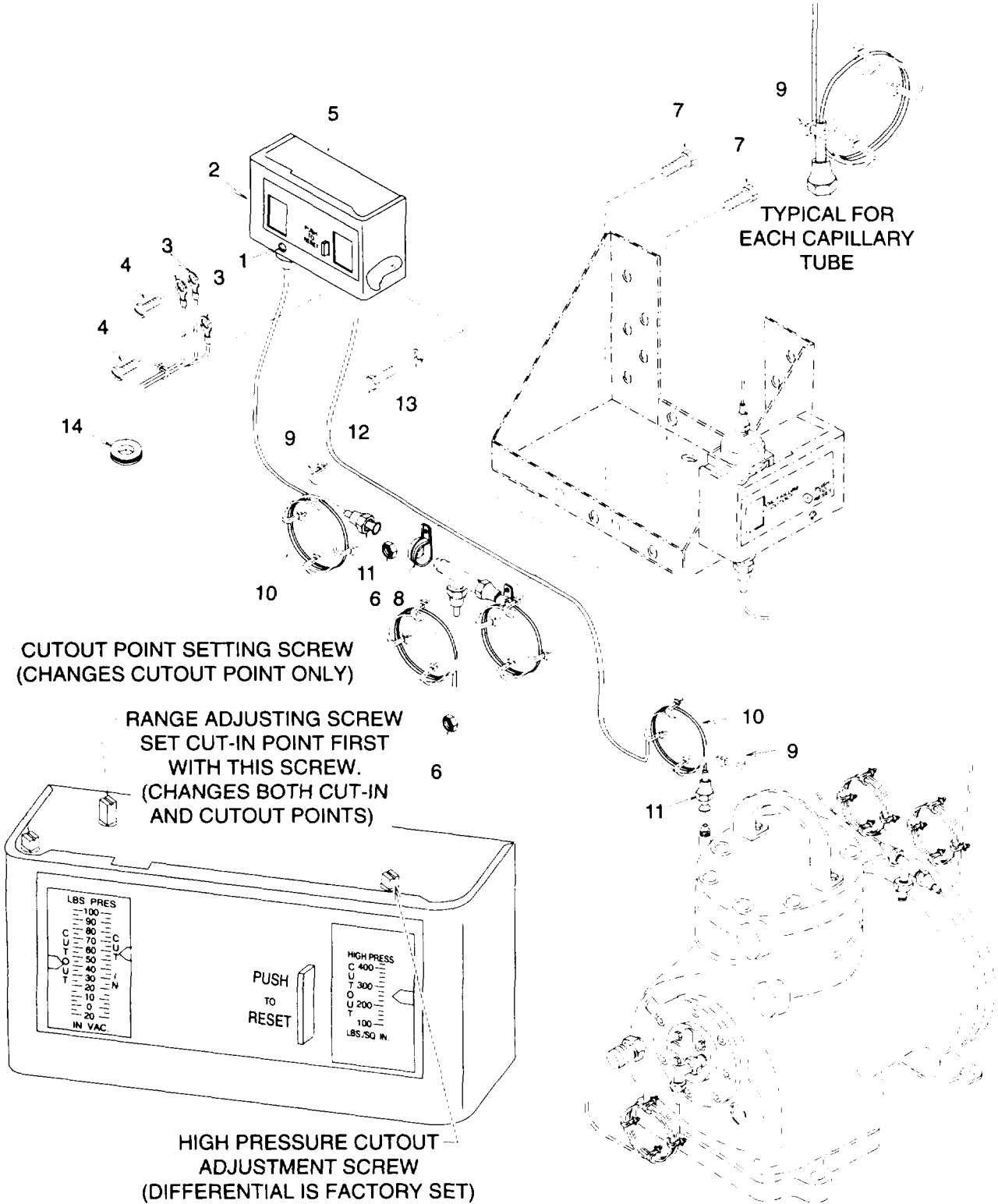

Figure 5-32. Dual Pressure Control Switch
5-64

- (3) Install dual pressure control switch (5), two new lock washers (13), and bolts (12).
- (4) Using tags on old dual pressure control switch (5) for reference, neatly route new capillary tubing to tees and carefully coil excess tubing as necessary.
- (5) Align each capillary tube (10) and tighten two flare nuts (11).
- (6) Install clamp (8) around capillary tube (10). Install bolt (7) and new self locking nut (6).
- (7) Secure each capillary tube (10) with tie down strap (9) as shown.
- (8) Push wire leads (3) through grommet (14) and into dual pressure control switch (5). Using tags and wiring diagram (fig. 2-4), install wire leads and secure with two screws (4). Remove tags.
- (9) Install cover (2) and tighten screw (1).
- (10) Adjust HIGH PRESSure CUTOUT to 305, low pressure CUT IN to 0, and low pressure CUTOUT to 15 IN. VAC.

NOTE

FOLLOW-ON MAINTENANCE:

Install battery (para 4-35).

Replace dehydrator (para 5-17).

Leak check (para 5-13), evacuate (para 5-14), and charge (para 5-15) the refrigeration system.

Close left side door.

5-37. HEAT EXCHANGER REPLACEMENT.

This task covers:

a. Removal

b. Installation

INITIAL SETUP

Materials/Parts:

Insulation Tape
6, Appendix E

Equipment Conditions:

Refrigeration system discharged (para 5-10) and
purged (para 5-11).
Evaporator coil removed (para 5-39).

a. Removal.

- (1) Remove insulation (1) as necessary.

NOTE

Note flow direction prior to removal.

- (2) Purge (para 5-11) and de-braze (para 5-12) four fittings (2) and remove heat exchanger (3).

5-37. HEAT EXCHANGER REPLACEMENT. - Continuedb. Installation.**NOTE**

Be sure to observe flow direction noted during removal.

- (1) Install heat exchanger (3) then purge (para 5-11) and baze (para 5-12) four fittings (2).
- (3) Install insulation (1) and secure with insulation tape as necessary.

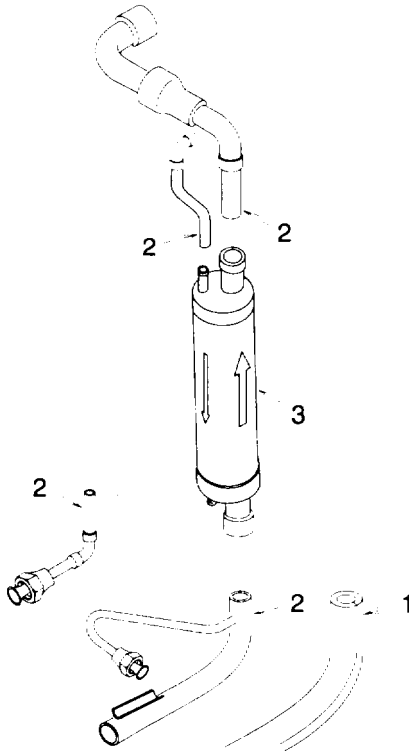

Figure 5-33. Heat Exchanger

NOTE**FOLLOW-ON MAINTENANCE:**

Install evaporator coil (para 5-39).

Replace dehydrator (para 5-17).

Leak check (para 5-13), evacuate (para 5-14), and charge (para 5-15) the refrigeration system.

5-38. EXPANSION VALVE REPLACEMENT.**This task covers:****a. Removal****b. Installation****INITIAL SETUP****Materials/Parts:**

Self Locking Nut
9, Appendix G
Tie Down Straps (2)
29, Appendix E
Insulation Tape
6, Appendix E

Equipment Conditions:

Refrigeration system discharged (para 5-10).
Access panel removed (para 4-16).

a. Removal.

- (1) Remove two screws (1) from expansion valve strap (2).
- (2) Remove self locking nut (3), screw (4), clamp (5), and expansion valve strap (2).
- (3) Remove insulation (6) as necessary to expose sensing bulb (7).
- (4) Remove and discard two tie down straps (8).
- (5) Loosen three flare nuts (9) and remove expansion valve (10).

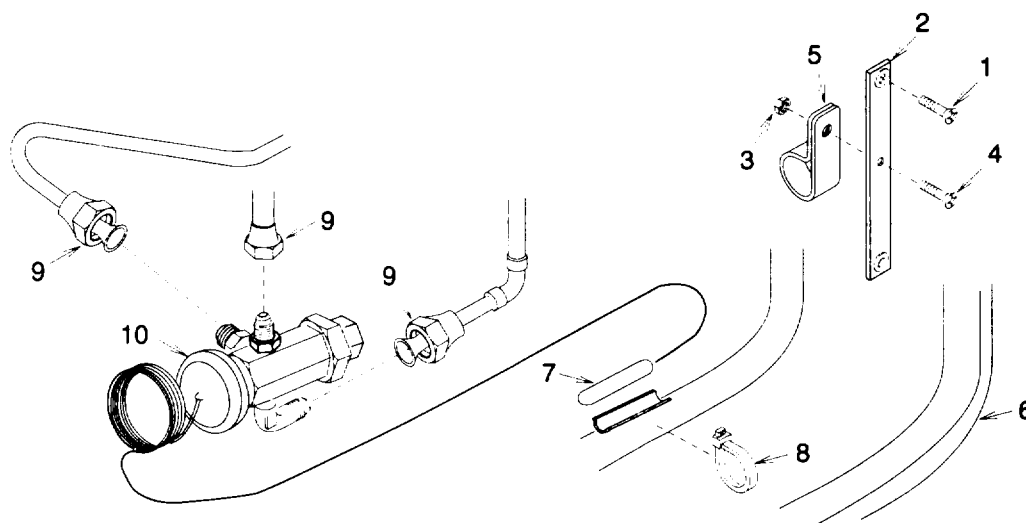
**Figure 5-34. Expansion Valve**

5-38. EXPANSION VALVE REPLACEMENT. - Continued

b. Installation.

- (1) Install expansion valve (10) and tighten three flare nuts (9).
- (2) Install sensing bulb (7) and secure with two new tie down straps (8).
- (3) Install insulation (6) and secure with insulation tape as necessary.
- (4) Slip clamp (5) over expansion valve body (10).
- (5) Secure clamp (5) to expansion valve strap (2) with screw (4) and new self locking nut (3).
- (6) Install expansion valve strap (2) and two screws (1)

NOTE

**FOLLOW-ON MAINTENANCE:
 Replace dehydrator (para 5-17).
 Leak check (para 5-13), evacuate (para 5-14), and charge (para 5-15) the refrigeration system.
 Install access panel (para 4-16).**

5-39. EVAPORATOR COIL REPLACEMENT.

This task covers:

a. Removal

b. Installation

INITIAL SETUP

Materials/Parts:

Lock Washers (10)
 1, Appendix G
 Insulation Tape
 6, Appendix E

Equipment Conditions:

Evaporator cover panel removed (para 4-15).
 Expansion valve removed (para 5-38).
 Temperature switch removed (para 4-36).
 Evaporator fan removed (para 4-42).

a. Removal.

- (1) Loosen two set screws (1) each on evaporator flange bearing, condenser flange bearing, and fan clutch (2) collars.
- (2) Slide fan drive shaft (3) away from evaporator coil (4) just enough to allow evaporator shroud (5) to be removed with the coil.
- (3) Remove insulation (6).
- (4) Remove two clamps (7).
- (5) Purge (para 5-11) and de-braze (para 5-12) three fittings (8).

WARNING

Coil fins are sharp and can cut hands or fingers. Wear gloves to prevent personal injury when handling coil.

- (6) Remove ten screws (9) and lift coil (4) and shroud (5) from frame (10).
- (7) Remove ten screws (11), lock washers (12), flat washers (13) and shroud (5). Discard lock washers.
- (8) Remove insulation (14).
- (9) Purge (para 5-11) de-braze (para 5-12) three fittings (15).

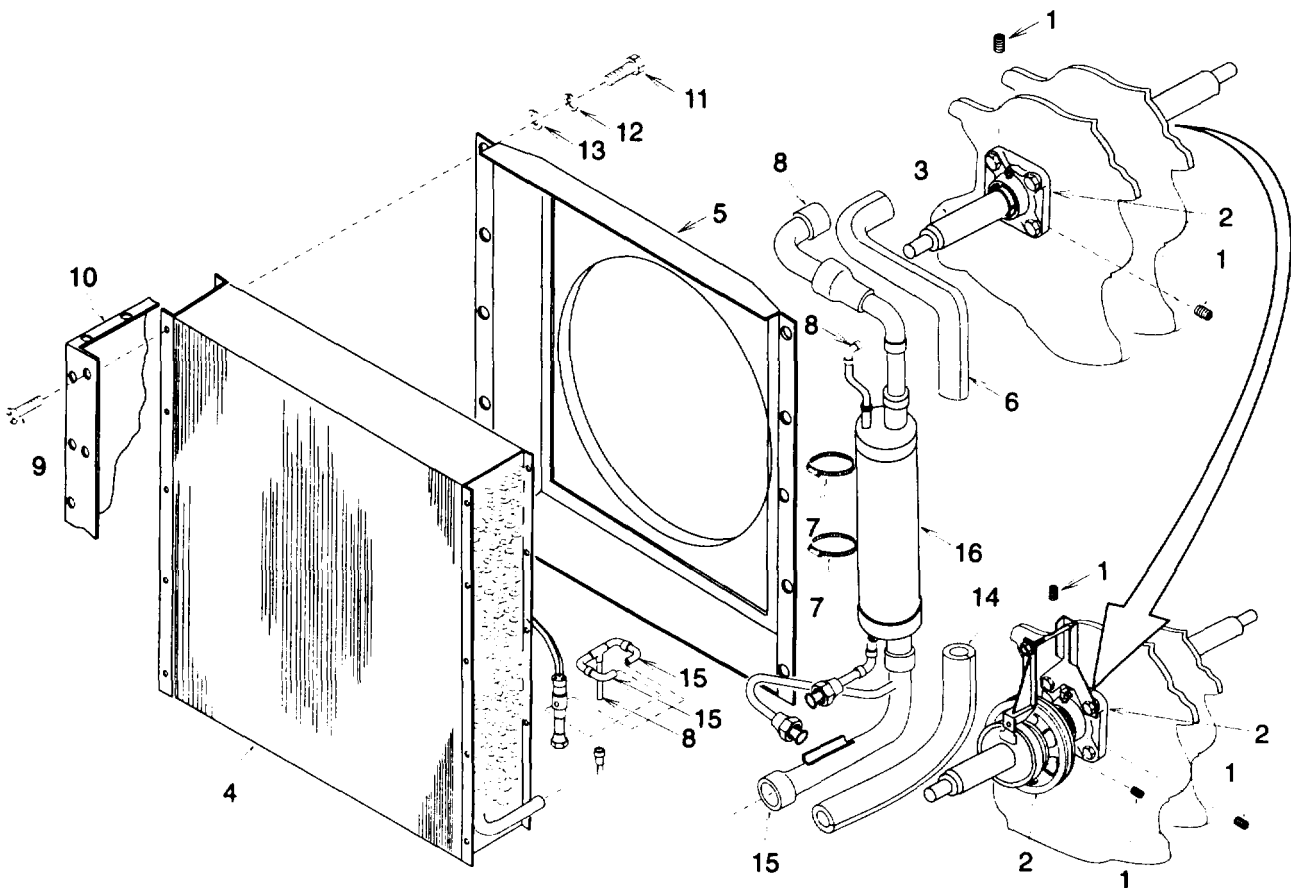

Figure 5-35. Evaporator Coil

5-39. EVAPORATOR COIL REPLACEMENT. - Continuedb. Installation.**WARNING**

Coil fins are sharp and can cut hands or fingers. Wear gloves t, personal injury when handling coil.

- (1) Install shroud (5) onto evaporator coil (4) using ten flat washers (13), new lock washers (12), and screws (11).
- (2) Purge (para 5-11) and braze (para 5-12) three fittings (15).
- (3) Install insulation (14) and secure using insulation tape as necessary.
- (4) Install evaporator coil (4) and shroud (5) into frame (10). Secure with ten screws (9).
- (5) Purge (para 5-11) and braze (para 5-12) three fittings (8).
- (6) Install two clamps (7) to secure heat exchanger (16).
- (7) Install insulation (6) and secure using insulation tape as necessary.
- (8) Slide fan drive shaft (3) back into place and tighten two set screws (1) each on both flange bearings and fan clutch collars (2).

NOTE**FOLLOW-ON MAINTENANCE:**

Install evaporator fan (para 4-42).

Install temperature switch (para 4-36).

Install expansion valve (para 5-38).

Replace dehydrator (para 5-17).

Leak check (para 5-13), evacuate (para 5-14), and charge (para 5-15) the refrigeration system.

Install evaporator cover panel (para 4-15).

5-40. COMPRESSOR B1 TESTING, SERVICE, REPAIR, AND REPLACEMENT.

This task covers:

- | | | |
|--|---|-------------------------|
| <p>a. Testing
d. Removal</p> | <p>b. Service
e. Installation</p> | <p>c. Repair</p> |
|--|---|-------------------------|

INITIAL SETUP

Materials/Parts:

- Self Locking Nuts (4)
30, Appendix G
- Lock Washers (4)
34, Appendix G
- Discharge Valve Stops (2)
41, Appendix G
- Discharge Valves (2)
35, Appendix G

- Suction Valves (2)
36, Appendix G
- Suction Valve Position Spring
39, Appendix G
- Gasket General Safety Instructions:
37, Appendix G
- Gasket
38, Appendix G
- Gasket
40, Appendix G
- Gasket
42, Appendix G
- Gasket
43, Appendix G
- Gasket
44, Appendix G

Materials/Parts:

- Marker tags (4)
4, Appendix E
- Anti-Seize Tape
27, Appendix E
- Compressor Lubricating Oil
28, Appendix E
- Insulation Tape
6, Appendix E

Equipment Conditions:

- Front door open.
- Right side door open.

WARNING

Compressor lubricating oil used in this refrigeration system is caustic. Wear gloves and a face protector or safety glasses in any situation where skin or eye contact is possible. If oil does contact skin, wash with soap and water.

a. Testing.

- (1) Remove compressor V-belts (para 4-38).
- (2) Discharge the refrigeration system (para 5-10).

WARNING

Dangerous pressure can remain trapped in compressor cylinder head. Removal of cylinder head bolts prior to relieving pressure can result in personal injury.

- (3) Loosen but do not remove six screws (1), and two studs (2). If cylinder head (3) is not loose, tap with lightweight hammer to loosen.

5-40. COMPRESSOR B1 TESTING. SERVICF. REPAIR, AND REPLACEMENT.-Continued

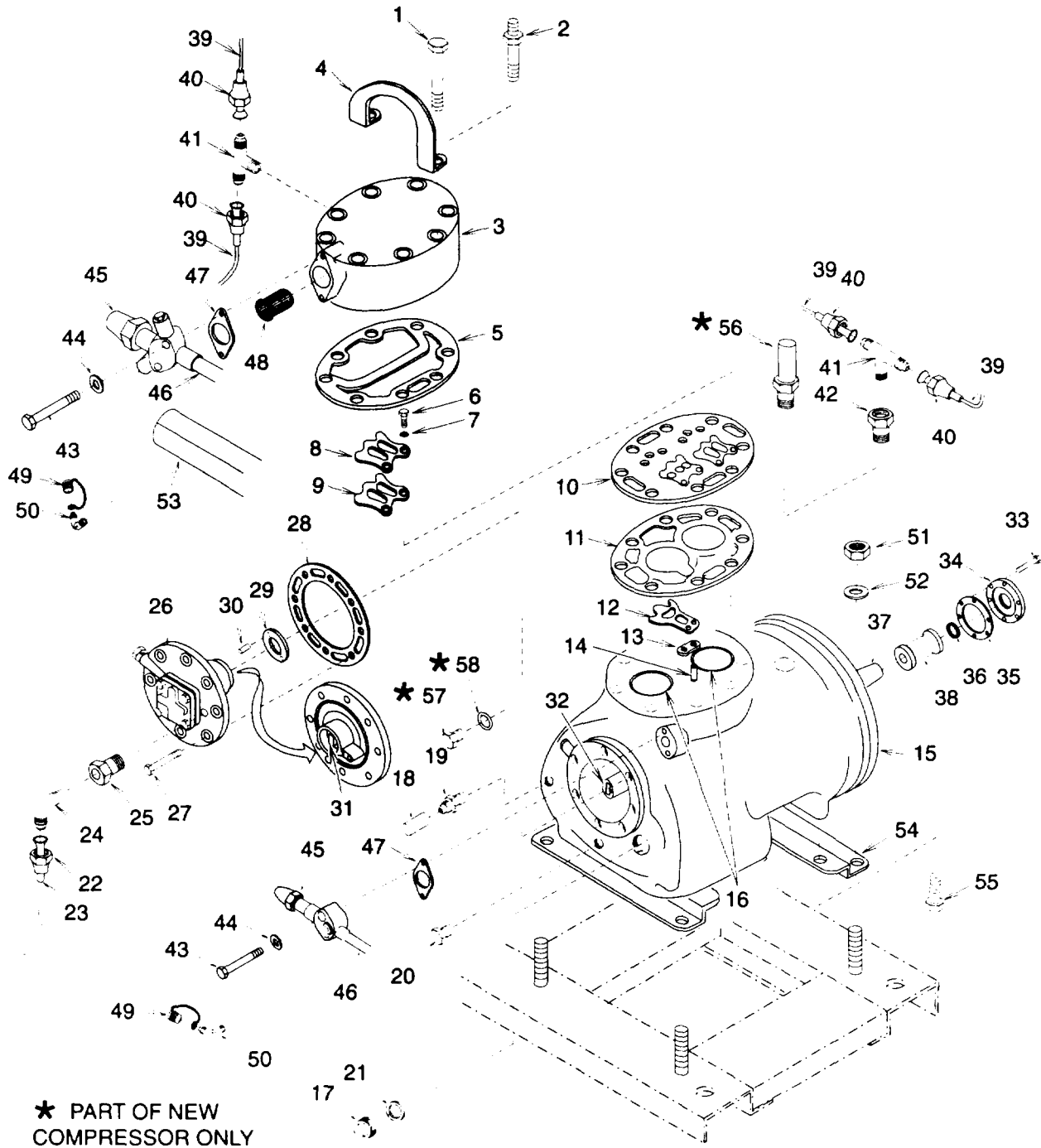

Figure 5-36. Compressor

NOTE

Valve plate, suction valves, position springs, and dowel pins may come off when removing cylinder head.

- (4) Remove six screws (1), lifting lug (4), two studs (2), cylinder head (3), and cylinder head gasket (5). Discard cylinder head gasket.
 - (5) Remove four screws (6), lock washers (7), two discharge valve stops (8), and discharge valves (9). Discard lock washers and discharge valves.
 - (6) Install two screws (6), without lock washers (7), into the outermost discharge valves (9) mounting holes to act as jackscrews to release valve plate (10).
 - (7) Remove valve plate (10), valve plate gasket (11), two suction valves (12), position springs (13), and four dowel pins (14). Discard valve plate gasket and suction valves.
 - (8) Examine compressor (15) cylinder walls for any scoring or excessive wear indicated by a groove at top of piston (16) travel. Replace compressor if scored or excessively worn.
 - (9) Press on top of highest piston (16). When pushed down, the piston should have some resistance and the other piston should move. Repeat for other piston when at highest point. If either piston was loose or did not cause the other one to move, replace compressor.
 - (10) If no failure was indicated, remove any gasket material from all machined gasket surfaces and install four dowel pins (14), two position springs (13) contacting on the ends and bowed out in the middle, new suction valves (12), new valve plate gasket (11), and valve plate (10).
 - (11) Check that suction valves (12) do not bind on valve plate gasket (11) by gently pushing on suction valve through intake hole in valve plate (10). Adjust valve plate gasket as necessary to prevent suction valve binding.
 - (12) Install two new discharge valves (9), discharge valve stops (8), four new lock washers (7), and screws (6).
 - (13) Install new cylinder head gasket (5), cylinder head (3), two studs (2), lifting lug (4), and six screws (1). Torque screws and studs to between 40 and 55 ft-lb (54 and 75 Nm).
 - (14) Replace dehydrator (para 5-17). Leak check (para 5-13), evacuate (para 5-14), and charge (para 5-15) the refrigeration system.
 - (15) Install and adjust compressor V-belts (para 4-38).
- b. Service. Check compressor lubricating oil level at sight glass (17). Level should be between 1/8 and 1/2 way up sight glass. Add or remove oil as necessary.
- (1) Discharge the refrigerant system (para 5-10).
 - (2) Add Oil.
 - (a) Remove cap (18).
 - (b) Add oil as necessary through schrader valve (19).
 - (c) Install cap (18).

5-40. COMPRESSOR B1 TESTING, SERVICE, REPAIR, AND REPLACEMENT .-Continued

(3) Remove Oil.

(a) Place drain pan under drain plug (20).

(b) Remove drain plug (20) and allow oil to drain as necessary.

(c) Install drain plug (20). Contact your local environmental officer for guidance on how to properly dispose of compressor oil in accordance with local regulation.

(4) Replace dehydrator (para 5-17). Leak check (para 5-13), evacuate (para 5-14), and charge (para 5-15) the refrigeration system.

c. Repair. Repair is limited to replacement of damaged components.

(1) Valve Plate Assembly.

(a) Discharge the refrigeration system (para 5-10).

WARNING

Dangerous pressure can remain trapped in compressor cylinder head. Removal of cylinder head bolts prior to relieving pressure can result in personal injury.

(b) Loosen but do not remove six screws (1), and two studs (2). If cylinder head (3) is not loose, tap with lightweight hammer to loosen.

NOTE

Valve plate, suction valves, position springs, and dowel pins may come off when removing cylinder head.

(c) Remove six screws (1), lifting lug (4), two studs (2), cylinder head (3), and cylinder head gasket (5). Discard cylinder head gasket.

(d) Remove four screws (6), lock washers (7), two discharge valve stops (8), and discharge valves (9). Discard lock washers and discharge valves.

(e) Install two screws (6), without lock washers (7), into the outermost discharge valves (9) mounting holes to act as jackscrews to release valve plate (10).

(f) Remove valve plate (10), valve plate gasket (11), two suction valves (12), position springs (13), and four dowel pins (14). Discard valve plate gasket and suction valves.

(g) Remove any gasket material from all machined gasket surfaces and install four dowel pins (14), two position springs (13) contacting on the ends and bowed out in the middle, new suction valves (12), new valve plate gasket (11), and valve plate (10).

(h) Check that suction valves (12) do not bind on valve plate gasket (11) by gently pushing on suction valve through intake hole in valve plate (10). Adjust valve plate gasket as necessary to prevent suction valve binding.

- (i) Install two new discharge valves (9), discharge valve stops (8), four new lock washers (7), and screws (6).
 - (j) Install new cylinder head gasket (5), cylinder head (3), two studs (2), lifting lug (4), and six screws (1). Torque screws and studs to between 40 and 55 ft-lb (54 and 75 Nm).
 - (k) Replace dehydrator (para 5-17). Leak check (para 5-13), evacuate (para 5-14), and charge (para 5-15) the refrigeration system.
- (2) Sight Glass.
- (a) Discharge the refrigeration system (para 5-10).
 - (b) Remove sight glass (17) and gasket (21). Discard gasket.
 - (c) Remove any gasket material from all machined gasket surfaces. Install new gasket (21) and sight glass (17). Torque sight glass to between 35 and 50 ft-lb (48 and 68 Nm).
 - (d) Replace dehydrator (para 5-17). Leak check (para 5-13), evacuate (para 5-14), and charge (para 5-15) the refrigeration system.
- (3) Oil Pump.
- (a) Discharge the refrigeration system (para 5-10).
 - (b) Loosen flare nut (22) and carefully pull tube (23) away being careful not to bend or kink tube.
 - (c) Remove elbow (24) and adapter (25).
 - (d) Note position of oil pump (26) and remove eight bolts (27), oil pump, gasket (28), thrust washer (29), and two pins (30). Discard gasket.
 - (e) Remove any gasket material from all machined gasket surfaces. Rotate oil pump coupling (31) to align with slot in compressor shaft (32). Install two pins (30), thrust washer (29), new gasket (28), oil pump (26) positioned as noted during removal, and eight bolts (27). Torque bolts to between 6 and 10 ft-lb (8 and 14 Nm).
 - (f) Wrap anti-seize tape around adapter (25) and elbow (24) threads. Install adapter and elbow.
 - (g) Align tube (23) being careful not to bend or kink tube. Tighten flare nut (22).
 - (h) Replace dehydrator (para 5-17). Leak check (para 5-13), evacuate (para 5-14), and charge (para 5-15) the refrigeration system.

5-40. COMPRESSOR B1 TESTING, SERVICE, REPAIR, AND REPLACEMENT .-Continued

(4) Shaft Seal.

CAUTION

- Carbon seals are fragile and must be handled with care to prevent damage.
 - Do not touch sealing surfaces of carbon seals with fingers. Acids in the skin will damage seal.
- (a) Discharge the refrigeration system (para 5-10).
 - (b) Remove compressor per d. below.
 - (c) Remove compressor pulley (para 5-6).
 - (d) Remove six bolts (33), seal plate (34), gasket (35), and carbon ring (36) being careful not to touch carbon sealing surfaces with fingers. Discard gasket, retain carbon ring and seal plate for use during assembly.
 - (e) Tap crankshaft (37) using appropriate hammer to loosen shaft seal (38).
 - (f) Using two long screwdrivers, remove shaft seal (38) by carefully prying it out. Discard shaft seal.
 - (g) Remove new carbon ring (36) from new shaft seal (38) being careful not to touch carbon sealing surfaces with fingers.
 - (h) Apply a small amount of lubricating oil onto new shaft seal (38) neoprene bellows where it contacts the crankshaft (37). Slide shaft seal onto crankshaft until it just starts to grip shaft being careful not to touch carbon sealing surfaces with fingers.

CAUTION

Carbon ring notches must be aligned with seal plate tabs when installed to prevent damaged.

- (i) Install old carbon ring (36) into old seal plate (34). Be sure notches in carbon ring align with tabs in seal plate. Be careful not to touch carbon sealing surfaces with fingers. Install seal plate and two bolts (33) on opposing sides. Tighten bolts to seat new shaft seal (38).
- (j) Remove two bolts (33), old seal plate (34), and old carbon ring (36). Discard seal plate and carbon ring.

CAUTION

Carbon ring notches must be aligned with seal plate tabs when installed to prevent damaged.

- (k) Apply a small amount of lubricating oil onto new carbon ring (36) and new seal plate (34) where it contacts carbon ring being careful not to touch carbon sealing surfaces with fingers. Be sure notches in carbon ring align with tabs in seal plate and install new carbon ring into new seal plate.

- (l) Remove any gasket material from all machined gasket surfaces. Install new gasket (35), new seal plate (34) with new carbon ring (36), and six bolts (33). Be careful not to touch carbon sealing surfaces with fingers. Torque bolts to between 15 and 21 ft-lb (20 and 29 Nm).
- (m) Replace dehydrator (para 5-17). Leak check (para 5-13), evacuate (para 5-14), and charge (para 5-15) the refrigeration system.
- (n) Install compressor pulley (para 5-6). Install compressor per e. below. Install and adjust compressor V-belts (para 4-38).

d. Removal.

- (1) Discharge the refrigeration system (para 5-10).
- (2) Remove compressor V-belts (para 4-38).
- (3) Tag tube (23) and four tubes (39). Loosen flare nut (22) and four flare nuts (40). Carefully pull tubes away being careful not to bend or kink tubes.
- (4) Remove elbow (24), adapter (25), two tees (41), and adapter (42).
- (5) Remove four bolts (43), and flat washers (44). Pull two service valves (45) away from compressor (15) being careful not to bend or kink tubing (46). Remove two service valve gaskets (47) and suction screen (48). Discard gaskets.
- (6) If damaged, remove two caps (49) and elbows (50).
- (7) Remove four self locking nuts (51) and flat washers (52). Discard self locking nuts.

WARNING

Compressor weight exceeds 84 lb. (38 kg). Use appropriate lifting device to avoid personal injury.

- (8) Remove compressor (15).
- (9) If damaged, purge (para 5-11) and de-braze (para 5-12) two service valves (45) from tubing (46). Remove insulation (53) as necessary. Remove two caps (49) and elbows (50) if attached.
- (10) Remove compressor pulley (para 5-6).
- (11) If either foot (54) is damaged, remove two screws (55) and foot.

5-40. COMPRESSOR B1 TESTING. SERVICE. REPAIR. AND REPLACEMENT.-Continuede. Installation.(1) Prepare New Compressor:

- (a) Remove schrader valve (56).
 - (b) Remove plug (57) with o-ring (58) and discard.
 - (c) Wrap anti-seize tape around threaded end of schrader valve (56) and install where plug (57) was removed.
 - (d) Install compressor pulley (para 5-6).
- (2) If removed, install two service valves (45) onto tubing (46) with mounting surfaces at right angles to each other then purge (para 5-11) and braze connections (para 5-12). Install insulation (53) and secure using insulation tape as necessary.
 - (3) If removed, wrap anti-seize tape around threaded end of two elbows (50) and install.
 - (4) If removed, install foot (54) and two screws (55).

WARNING

Compressor weight exceeds 84 lb. (38 kg). Use appropriate lifting device to avoid personal injury.

- (5) Install compressor (15) and align mounting holes.
- (6) Install four flat washers (52), and new self locking nuts (51).
- (7) Install suction screen (48). Carefully align two service valves (45) being careful not to bend or kink tubing (46). Install two new service valve gaskets (47), flat washers (44), and four bolts (43). Torque bolts to between 15 and 25 ft-lb (20 and 34 Nm).
- (8) Wrap anti-seize tape around threaded end of elbow (24), adapter (25), two tees (41), and adapter (42). Install adapters, elbow, and tees.
- (9) Align tube (23) and four tubes (39) using tags as reference. Be careful not to bend or kink tubes. Tighten flare nut (22) and four flare nuts (40). Remove tags.
- (10) Install and adjust compressor V-belts (para 4-38).
- (11) Replace dehydrator (para 5-17). Leak check (para 5-13), evacuate (para 5-14), and charge (para 5-15) the refrigeration system.

NOTE**FOLLOW-ON MAINTENANCE**

**Close right side door.
Close front door.**

5-41. TUBING AND FITTINGS TESTING, REPAIR, AND REPLACEMENT**This task covers:****a. Testing****b. Removal****c. Installation****INITIAL SETUP****Materials/Parts:**

Silicone RTV

1, Appendix E

Tie Down Strap(s) (As Required)

29, Appendix E

Equipment Conditions:

Doors, panels, guards open/removed as necessary.

General Safety Instructions:**WARNING****High voltage and rotating parts are used in the refrigeration unit. Personal injury can result if battery is connected.**

- a. Testing. Leak test the tubing and fittings (para 5-13).

NOTE**Repair consists of replacing damaged or leaking tubing and/or fittings.**

- b. Removal.

- (1) Discharge (para 5-10) the refrigeration system.
- (2) If a flare connection was leaking, loosen flare nut and cut the damaged flare off the tubing end.
- (3) Purge (para 5-11) and de-braze (para 5-12) any fitting or tubing that was leaking or was too short to flare.
- (4) Remove any silicone RTV remaining in evaporator frame grommets.

- c. Installation.

- (1) Purge (para 5-11) and braze (para 5-12) any loose tubing or fitting connections.
- (2) Flare tubing end where damaged flare was removed or on end of new tube if it was too short to flare.
- (3) Replace dehydrator (para 5-17).
- (4) Leak check (para 5-13), evacuate (para 5-14), and charge (para 5-15) the refrigeration system.
- (5) Apply silicone RTV into evaporator frame grommets to seal evaporator enclosure.
- (6) Secure capillary lines to pipe illustrated using tie down strap(s) as necessary.

5-41. TUBING AND FITTINGS TESTING, REPAIR, AND REPLACEMENT .-Continued

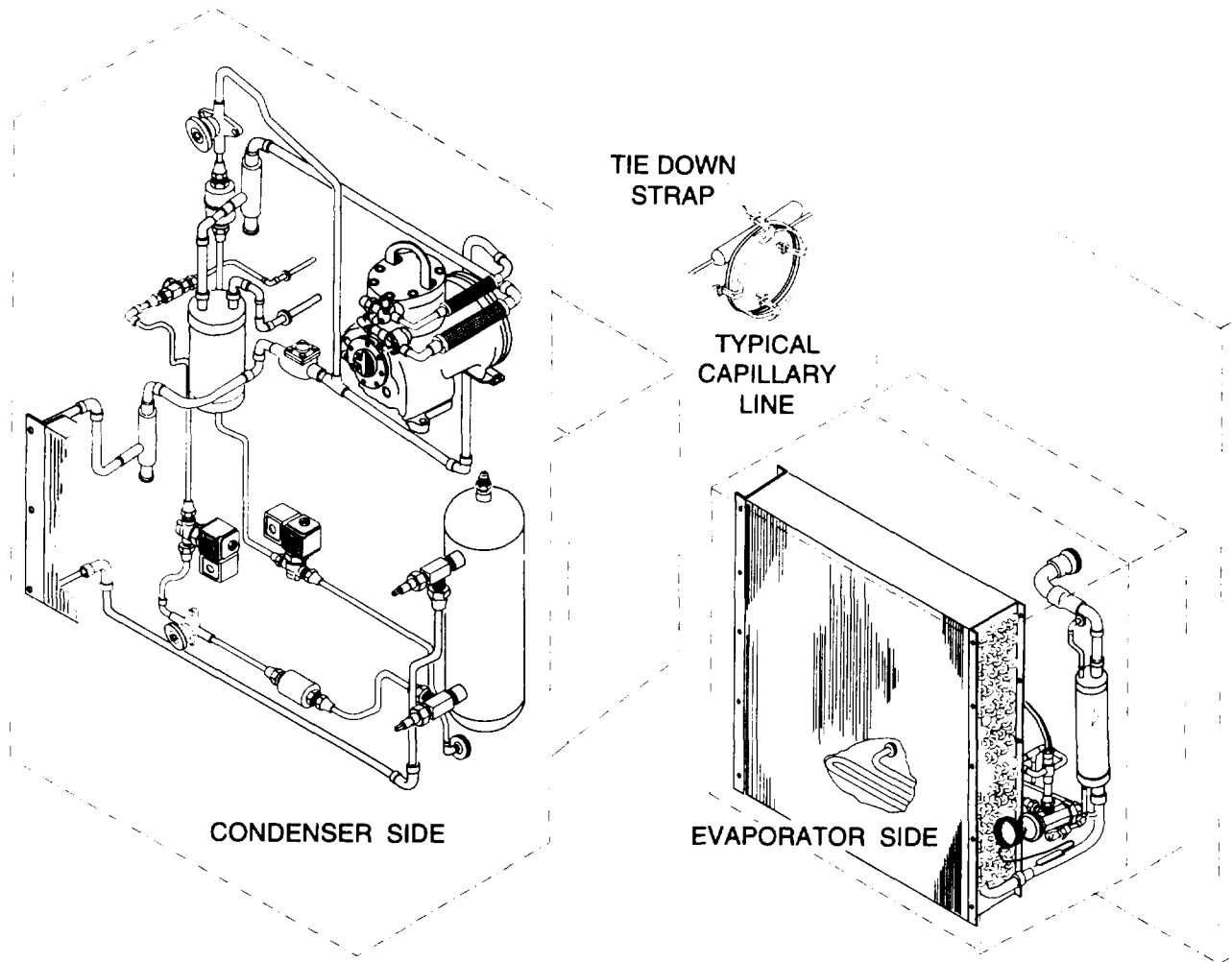

Figure 5-37. Tubing And Fittings

NOTE

FOLLOW-ON MAINTENANCE:
Close/install any doors, panels, guards removed.

5-42. NOZZLE TESTING AND REPLACEMENT.**This task covers:****a. Removal****b. Testing****c. Installation****INITIAL SETUP****Tools:**

Injector Test Bench
7, Section III, Appendix B
Injector Extractor
10, Section III, Appendix B
Mechanical Puller
11, Section III, Appendix B

Materials / Parts:

Wiping Rags
9, Appendix E
Washer
46, Appendix G
Washer
47, Appendix G

Equipment Conditions:

Top access panel removed (para 4-13).
Fuel supply tube removed from nozzle (para 4-62).
Fuel return hose removed from nozzle (para 4-63).

a. Removal.

- (1) Remove nut (1) and washer (2).

NOTE

The nozzle assembly uses special washers as spacers/seals. The washers are not re-usable and must be replaced with the same quantity and thickness washers during installation.

- (2) Assemble injector extractor and mechanical puller, attach to nozzle assembly (3) and remove nozzle assembly with washer(s) (4) and brace (5). Note quantity and thickness of washers. Discard washers.
- (3) If stud (6) is damaged, remove it.

b. Testing.

- (1) Place the nozzle assembly (3) on the injector test bench and bypass the pressure gauge so it does not read injector test bench pressure.

5-42. NOZZLE TESTING AND REPLACEMENT.-Continued**WARNING**

- Before applying pressure to the nozzle tester, be sure that all connections are tight, and that the fittings are not damaged. Fluid escaping from a very small hole can be almost invisible. Use a piece of cardboard or wood, rather than hands, to search for suspected leaks.
 - Fuel from the spray orifices can penetrate clothing and skin causing serious personal injury. The nozzle tip should always be directed away from the operator. Enclosing the nozzle in a transparent cover is recommended. Place a clear, protective shield around spray zone to avoid possible personal injury from spray.
 - If injured by escaping fluid, see a doctor at once. Serious infection or reaction can develop if proper medical treatment is not administered immediately.
- (2) Operate the injector test bench lever rapidly. The nozzle assembly (3) should chatter audibly and spray evenly.
 - (3) With pressure gage reading injector test bench pressure, press the lever slowly and steadily until fuel is sprayed from nozzle assembly (3). The pressure registered on the gauge should be 3,071 to 3,471 psi (21,190 to 23,950 kPa). If pressure is not met, replace nozzle.
 - (4) Slowly press injector test bench hand lever until the pressure gauge reads 2986 psi (20,603 kPa). Hold at this pressure for 10 seconds. No diesel fuel should accumulate at the nozzle tip. If fuel is detected, replace nozzle.
 - (5) If no failure was indicated, install nozzle assembly (3).

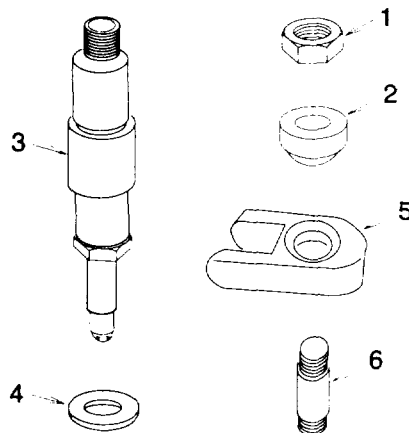

Figure 5-38. Nozzle

d. Installation.

- (1) If removed, install stud (6).

NOTE

- **The nozzle assembly uses special washers as spacers/seals. The washers are not re-usable and must be replaced with the same quantity and thickness washers removed.**
 - **The mounting brace is beveled to cup the bevel on the mating washer.**
- (2) Install new washer(s) (4) as noted during removal, nozzle (3), brace (5) with bevel up, washer (2) with bevel down, and nut (1). Torque nut to between 27 and 31 ft lb (37 and 42 Nm).

NOTE

FOLLOW-ON MAINTENANCE:
Install fuel supply tube onto nozzle (para 4-62).
Install fuel return hose onto nozzle (para 4-63).
Install access panel (para 4-13).

5-43. INJECTION PUMP TESTING, REPLACEMENT, AND ADJUSTMENT.**This task covers:**

- | | | |
|---|-------------------|------------------------|
| a. Testing
d. Adjustment | b. Removal | c. Installation |
|---|-------------------|------------------------|

INITIAL SETUPTools:

Fuel Delivery Sight
8, Section III, Appendix B

Materials/Parts:

Gasket(s) (0.1) (As Required)

54, Appendix G

Gasket(s) (0.3) (As Required)

60, Appendix G

Gasket

17, Appendix G

Materials/Parts:

Gasket

52, Appendix G

Gasket(s) (0.2) (As Required)

49, Appendix G

Wiping Rags

9, Appendix E

Equipment Conditions:

Refrigeration unit shut down (para 2-7) and battery disconnected (para 4-35).

Left side door open.

a. Testing.

- (1) Remove screw (1), flat washer (2), and cylinder casing (3).
- (2) Remove three screws (4), cover (5), and gasket (6). Discard gasket.

CAUTION

Always use two wrenches when loosening the fuel pipe to prevent turning the nozzle or injection pump fitting.

- (3) Loosen two flare nuts (7) and remove fuel pipe (8).
- (4) Connect a pressure gauge with a reading capacity of 8,532 psi (58,871 kPa) full scale to the M12 x 1.5 injection pump fitting (9).
- (5) Set and secure the manual shut down lever (10) to the full open position (right).

WARNING

Before applying pressure to the gauge, be sure that all connections are tight, and that the fittings are not damaged. Fluid escaping from a very small hole can be almost invisible. Use a piece of cardboard or wood, rather than hands, to search for suspected leaks.

- (6) Monitor the pressure gage reading and slowly turn the engine flywheel (11) clockwise. Note the maximum pressure indicated on the gage. If the pressure does not reach 4,266 psi (29,435 kPa) or above, the injection pump (12) must be replaced.

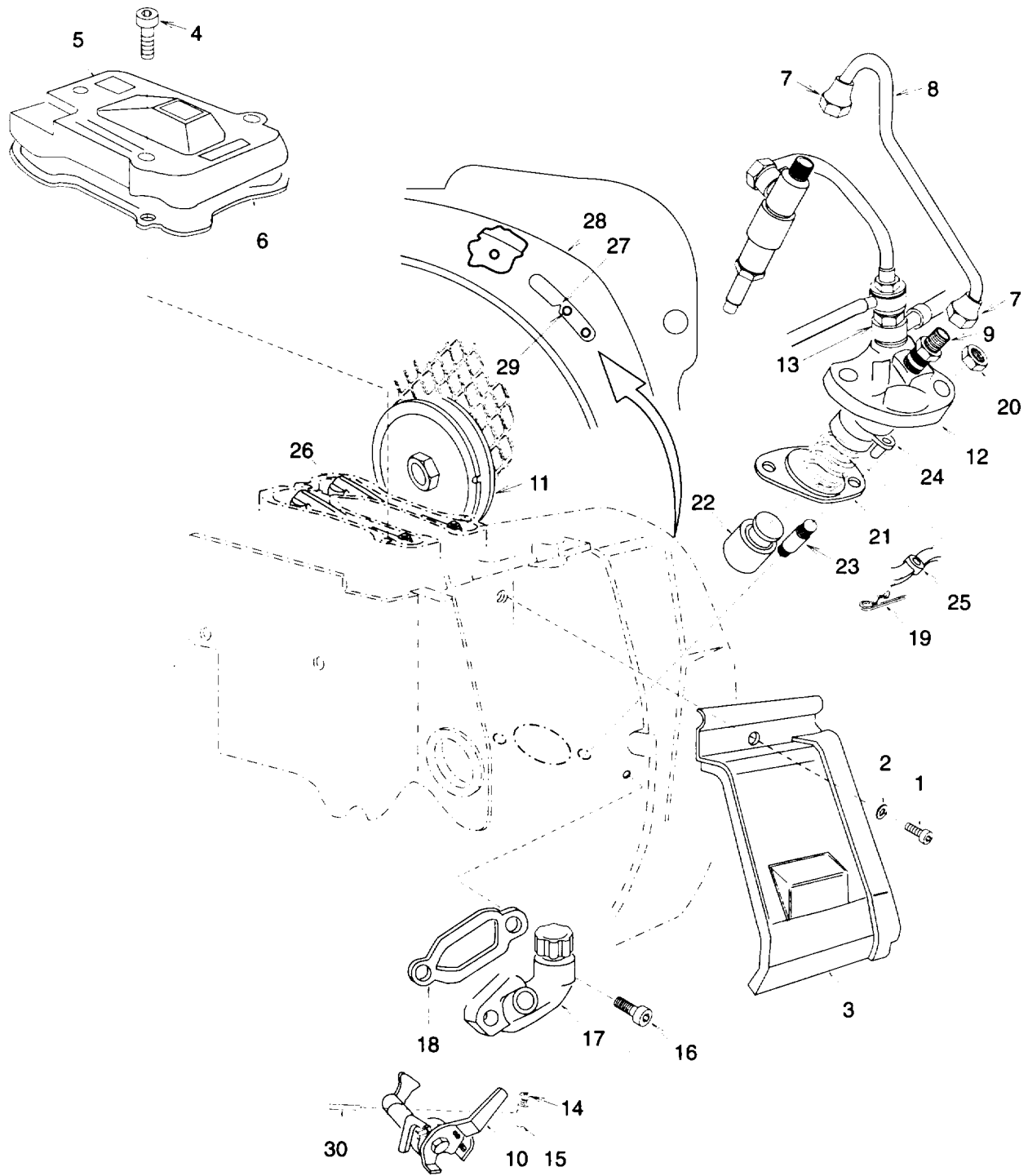

Figure 5-39. Fuel Injection Pumps

5-40. INJECTION PUMP TESTING, REPLACEMENT, AND ADJUSTMENT .-Continued

- (7) Monitor the pressure gage reading and slowly turn the engine flywheel (11) clockwise. The reading on the gage will show a progressive pressure increase to the maximum value noted in step (6), then will begin to drop suddenly. Stop turning the engine pulley at this point and monitor the gage reading as well as the time it takes the pressure to stop dropping. Note the final pressure reading, to establish the pressure drop, and the elapsed time.
- (a) If the total pressure drop was greater than 50 psi (4906 kPa), replace the injection pump (12).
- (b) If the drop occurred in less than 7 seconds, replace the injection pump (12).
- (c) If the pressure dropped suddenly as expected but continued to fall slowly, replace the injection pump (12).

CAUTION

Always use two wrenches when tightening the fuel pipe to prevent turning the nozzle or injection pump fitting.

- (8) If no failure was indicated, remove pressure gage and install fuel pipe (8). Tighten two flare nuts (7) to between 11 and 18 ft-lb (15 and 25 Nm).
- (9) Install new gasket (6), cover (5) and three screws (4).
- (10) Install cylinder casing (3), flat washer (2), and screw (1).
- (11) Release manual shut down lever (10).

b. Removal.

- (1) Remove screw (1), flat washer (2), and cylinder casing (3).
- (2) Remove three screws (4), cover (5) and gasket (6). Discard gasket.

CAUTION

Always use two wrenches when loosening the fuel pipe to prevent turning the nozzle or injection pump fitting.

- (3) Loosen two flare nuts (7) and remove fuel pipe (8).
- (4) Remove fuel filter to injection pump hose assembly (13) (para 4-62).
- (5) Loosen screw (14) and remove clamp (15).
- (6) Remove two screws (16), cover (17), and gasket (18). Discard gasket.
- (7) Remove clip (19).

NOTE

The injection pump uses special gaskets as shims/seals and are not re-usable. The quantity and thickness of gaskets determines the timing of the injection pump.

- (8) Remove two nuts (20), injection pump (12), and gasket(s) (21). Note quantity and thickness of gasket(s) and discard.

NOTE

The injection pump tappet can remain in the engine.

- (9) If tappet (22) is attached to injection pump (12) spring, remove it.

- (10) Remove stud(s) (23) if damaged.

c. Installation.

- (1) If removed, install stud(s) (23).

NOTE

The injection pump uses special gaskets as shims/seals and are not re-usable. The quantity and thickness of gaskets determines the timing of the injection pump.

- (2) Install tappet (22) if removed, new gasket(s) (21) as noted during removal, and injection pump (12) being careful to align lever arm (24) with hole in connecting rod (25). Install two nuts (20) and clip (19). Torque nuts to between 27 and 31 ft lb (37 and 42 Nm).

- (3) Check adjustment of injection pump (12).

d. Adjustment.

- (1) Install fuel filter to injection pump hose assembly (13) (para 4-61).

NOTE

The intake rocker arm will be in line with the intake manifold port.

- (2) Place a rag over injection pump fitting (9). Slowly rotate engine flywheel (11) clockwise and observe the intake rocker arm (26) movement. The intake rocker arm will move down during an intake stroke and then begin to rise as the compression stroke begins. Stop rotating the engine pulley at this point.

- (3) Position the connecting rod (25) at full open position (right).

5-40. INJECTION PUMP TESTING, REPLACEMENT, AND ADJUSTMENT .-Continued

- (4) Install the fuel delivery sight onto the injection pump fitting (9).

NOTE

It may be necessary to rotate the flywheel several turns in order to get fuel to become visible in the fuel delivery sight.

- (5) Slowly rotate engine flywheel (11) clockwise until the column of diesel fuel inside the fuel delivery sight starts to move. This indicates the start of static injection.
- (6) The reference mark (27) on shroud (28) should match the static injection point (29) (middle dot) punched onto the flywheel (11).

NOTE

Each 0.003 inch (0.1 mm) gasket inserted beneath the injection pump correspond to 1.38° of rotation on the flywheel.

- (7) If the static injection point (29) is to the left (counterclockwise) side of reference mark (27), the timing is too advanced and the injection pump (12) must be removed and installed with additional gasket(s) (23).
- (8) If the static injection point (29) is to the right (clockwise) side of reference mark (27), the timing is too retarded and the injection pump (12) must be removed and installed with fewer gasket(s) (23).
- (9) Position manual shut down lever (10) fully to the right (clockwise).
- (10) Be sure manual shut down lever (10) is fully to the right then install new gasket (8), cover (17), and two screws (16).
- (11) Pass wire (30) through manual shut down lever (10) and clamp (15). Position manual shut down lever fully to the left then slide clamp against lever and tighten screw (14).

CAUTION

Always use two wrenches when tightening the fuel pipe to prevent turning the nozzle or injection pump fitting.

- (12) Install fuel pipe (8) and tighten two flare nuts (7). Torque flare nuts to between 11 and 18 ft-lb (15 and 25 Nm).
- (13) Install new gasket (6), cover (5), and three screws (4).
- (14) Install cylinder casing (3), flat washer (2), and screw (1).

NOTE

**FOLLOW-ON MAINTENANCE:
Connect battery (para 4-35) and put unit back into service.**

5-44. FUEL PUMP REPLACEMENT.

This task covers:

a. Removal**b. Installation****INITIAL SETUP****Materials/Parts:**

Wiping Rags

9, Appendix E

Gasket(s) (As Required)

61, Appendix G

Gasket(s) (As Required)

48, Appendix G

Gasket

50, Appendix G

Washers (4)

16, Appendix G

Equipment Conditions:

Refrigeration unit shut down (para 2-7) and battery disconnected (para 4-35).

Front door open.

a. Removal.**WARNING**

Fuel pump may contain fuel. Injury to personnel can occur when removing. Appropriate actions should be taken to contain spills.

- (1) Remove two unions (1), washers (2), eyes (3), and washers (4). Discard washers.

NOTE

The fuel pump uses special gaskets as shims/seals and are not re-usable.

- (2) Remove two nuts (5), fuel pump (6), gasket(s) (7) (note quantity and thickness of gasket(s)), support (8), and gasket (9). Tappet (10) can be removed, be careful not to loose it. Discard gaskets.
- (3) Remove stud(s) (11) if damaged.

b. Installation.

- (1) If removed, install stud(s) (11).
- (2) Install new gasket (9), support (8), and tappet (10) if removed. Push tappet with finger and slowly rotate engine pulley (12) counterclockwise until tappet is at lowest point (farthest into the engine).

5-44. FUEL PUMP REPLACEMENT.-Continued**CAUTION**

The fuel pump uses special gaskets as shims/seals. The quantity and thickness of gaskets is important to prevent damaged to the fuel pump.

NOTE

Gasket thickness is either 0.008 in. (0.2 mm) or 0.040 in. (1.0 mm).

- (3) Install new gasket(s) (7) as noted during removal. Measure the distance from the gasket(s) surface to the end of tappet (10). Increase or decrease gaskets to attain a distance between 0.045 in. and 0.067 in. (1.3 mm and 1.7 mm).

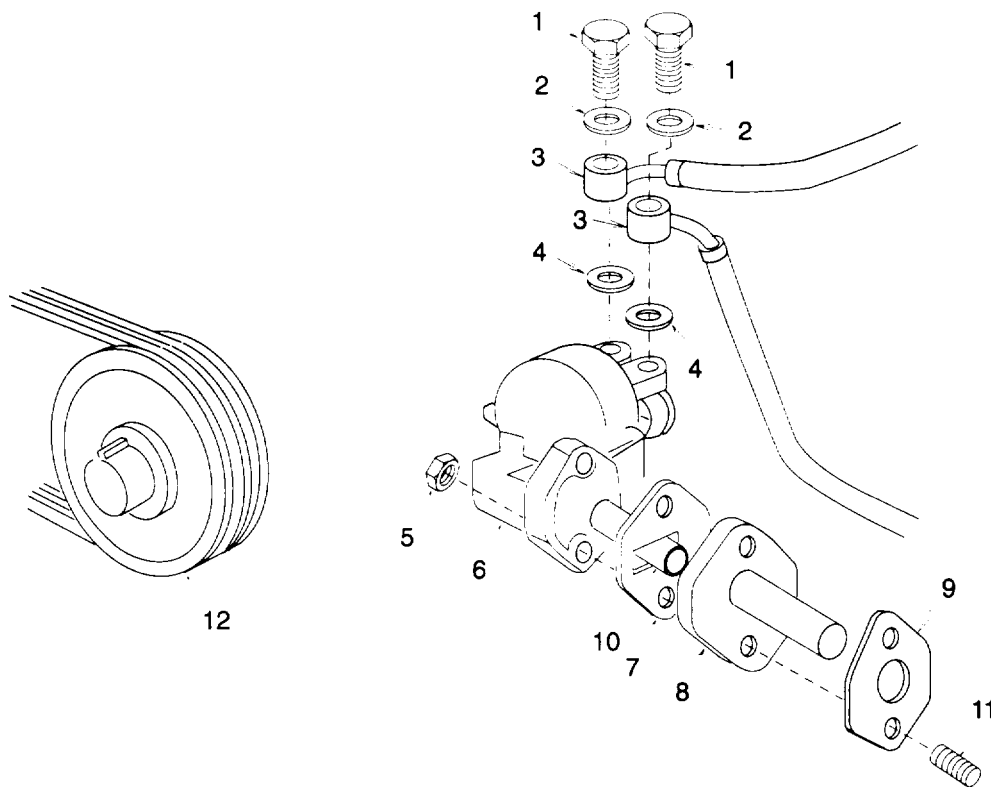

Figure 5-40. Fuel Pump

- (4) Install fuel pump (6) and two nuts (5).
 (5) Install two new washers (4), eyes (3), new washers (2), and unions (1).

NOTE**FOLLOW-ON MAINTENANCE:**

Close front door.

Connect battery (para 4-35) and put unit back into service.

5-45. CYLINDER HEAD TESTING, REPLACEMENT, AND ADJUSTMENT.**This task covers:****a. Removal****b. Test****c. Installation****INITIAL SETUP**Tools:

Valve Adjustment Tool
12, Section III, Appendix B

Materials/Parts:

Wiping Rag
9, Appendix E
Diesel Fuel

13, Appendix E
Gasket
17, Appendix G
Gaskets (2)
31, Appendix G

Materials/Parts:

Gasket
51, Appendix G
Gasket
15, Appendix G
O-Rings (4)
56, Appendix G

Equipment Conditions:

Top access panel removed (para 4-13).
Air inlet elbow removed (para 4-50).
Front door open.
Left side door open.

a. Removal.

- (1) Remove two screws (1), muffler assembly (2), and gasket (3). Discard gasket.
- (2) Remove two bolts (4) and flat washers (5).
- (3) Remove two screws (6) and gate (7).
- (4) Remove nut (8) and hook (9). Note location of hook for installation.
- (5) Remove three screws (10), cover (11), and gasket (12). Discard gasket.

CAUTION

Removal of the cylinder head when the engine is hot could result in damage or deformation of the cylinder heads.

- (6) Remove three nuts (13), nut (14) and four flat washer (15). Note location of nuts for installation.
- (7) Carefully remove cylinder head (16), gasket (17), two o-rings (18), protection pipes (19), o-rings (20), and rods (21). Discard gasket and o-rings.

5-45. CYLINDER HEAD TESTING, REPLACEMENT, AND ADJUSTMENT .-Continued

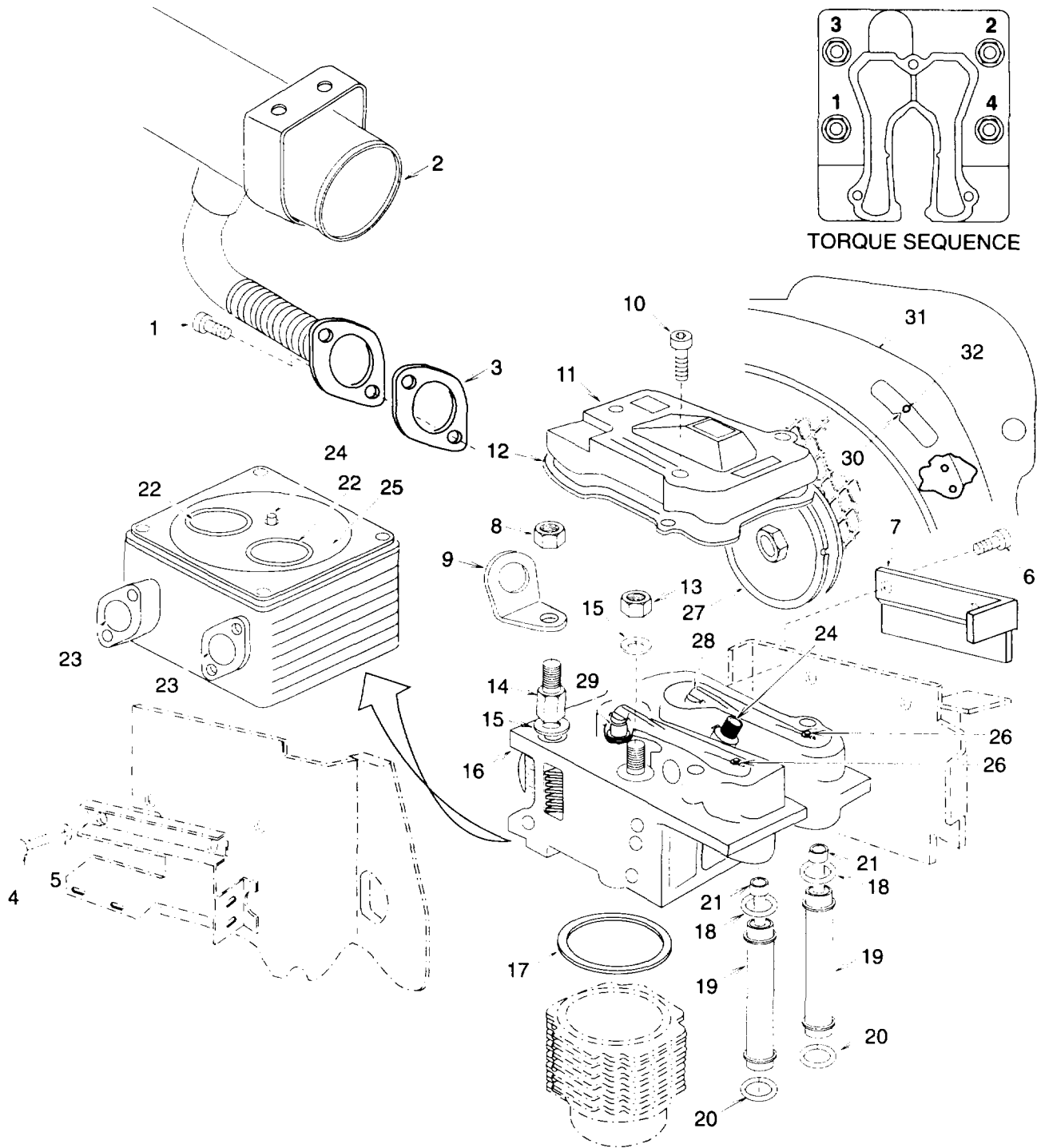

Figure 5-41. Cylinder Head

b. Testing.

- (1) Remove cylinder head (16) per a. above.
- (2) Invert cylinder head (16) and pour enough diesel fuel into cylinder head to pool around valve seats (22).
- (3) Examine each port (23) for three minutes. If fuel accumulates in a port, replace the cylinder head (16). Contact your local environmental officer for guidance on how to properly dispose of diesel fuel in accordance with local regulation.
- (4) If cylinder head (16) must be replaced, remove nozzle (24) (para 5-42).
- (5) If no failure was indicated, install cylinder head (16) per c. below.

c. Installation.

- (1) Clean carbon deposits from all mating surfaces. Check cylinder head (16) for any cracks or other damage that would affect operation of the engine. If damaged, cylinder head must be replaced.
- (2) Install nozzle (24) if removed (para 5-42).
- (3) If nozzle (24) was removed, check the distance between nozzle tip and cylinder head face (25). The distance must be between 0.069 in. and 0.089 in. (1.75 mm and 2.25 mm). If the distance is not within this range, remove and install the nozzle (para 5-42) adding or removing washers as necessary between nozzle and cylinder head (16).
- (4) Install two new o-rings (20), protection pipes (19), new o-rings (18), and rods (21).
- (5) Install new gasket (17).
- (6) Install cylinder head (16) being careful to align it onto protection pipes (19).
- (7) Install four flat washers (15), three nuts (13), and nut (14) as noted during removal. Torque nuts in increments of 13 ft lb (18 Nm) each in the order shown until 53 ft lb (83 Nm) is reached.
- (8) Install hook (9) and nut (8).

5-45. CYLINDER HEAD TESTING, REPLACEMENT, AND ADJUSTMENT .-Continued

- (9) Install gate (7) and two screws (6).
- (10) Install two flat washers (5) and bolts (4).
- (11) Install new gasket (3), muffler assembly (2), and two screws (1).

d. Adjustment.

- (1) Press on both rocker adjusting screws (26) while rotating engine flywheel (27) clockwise until both rocker arms (28) are up off valve stems (29) and reference mark (30) on shroud (31) is aligned with the piston top dead center point (32) (third/last dot) punched onto the flywheel (27).
- (2) Using valve adjustment tool, adjust each rocker arm (28) for a clearance to the valve stem (29) of 0.006 in. (0.15 mm).
- (3) Install new gasket (12), cover (11), and three screws (10).

NOTE

FOLLOW-ON MAINTENANCE:
Install air inlet elbow and air cleaner (para 4-50).
Install top access panel (para 4-13).
Close front door. Close left side door.

5-46. ENGINE OIL PUMP INSPECTION AND REPLACEMENT.

This task covers:

a. Removal

b. Inspection

c. Installation

INITIAL SETUP

Materials/Parts:

O-ring
 57, Appendix G

Equipment Conditions:

Left side door open.
 Refrigeration unit shut down (para 2-7) and battery disconnected (para 4-35).

a. Removal.

- (1) Remove three screws (1), cover (2), and o-ring (3). Discard o-ring.
- (2) Remove internal rotor (4) and external rotor (5).

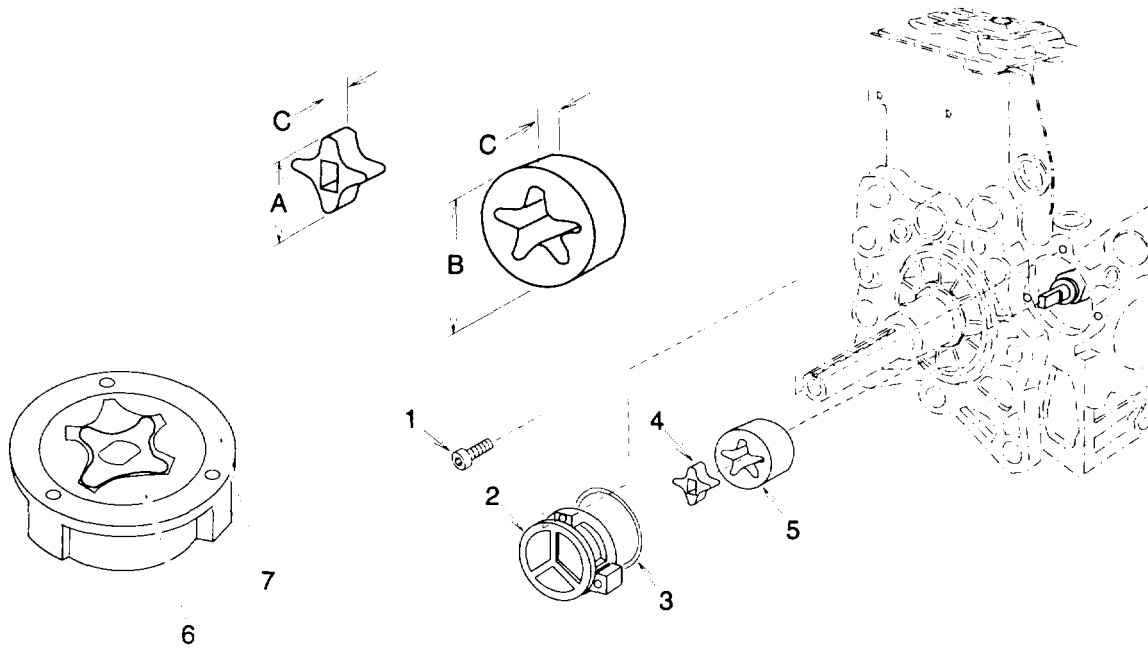

Figure 5-42. Engine Oil Pump

b. Inspection.

- (1) Check rotor (4) and (5) wear by measuring them and checking against the following dimensions. Replace rotor if not between these dimensions.

A	1.167 in. and 1.172 in. (29.65 mm and 29.77 mm)
B	1.592 in. and 1.597 in. (40.45 mm and 40.576 mm)
C	0.704 in. and 0.706 in. (17.89 mm and 17.94 mm)

NOTE

The rotor must be within dimensions before checking cover wear.

- (2) Check cover (2) wear by placing rotor (5) inside cover. Be sure o-ring (3) is not installed in cover and measure the distance between rotor surface (6) and cover edge (7). The dimension should be between 0.010 in. and 0.023 in. (0.27 mm and 0.60 mm). Replace the cover if not between these dimensions.

5-46. ENGINE OIL PUMP INSPECTION AND REPLACEMENT .-Continued**c. Installation.**

- (1) Install rotor (4) with the bevel facing out.
- (2) Install rotor (5) with bevel facing out.
- (3) Install new o-ring (3) into cover (2).
- (4) Install cover (2) and three screws (1). Torque screws to between 65 ft lb and 80 ft lb (88 Nm and 109 Nm).

NOTE**FOLLOW-ON MAINTENANCE:****Close left side door.****Connect battery (para 4-35) and put unit back into service.****5-47. FLYWHEEL REPLACEMENT.**

This task covers:**a. Removal****b. Installation**

INITIAL SETUP**Tools:**Flywheel puller
9, Appendix B**Equipment Conditions:**Left side door open.
Front door open.
Refrigeration unit shut down (para 2-7) and battery
disconnected (para 4-35).

a. Removal.

- (1) Remove screw (1), flat washer (2), and cylinder casing (3).
- (2) Remove two screws (4) and cover (5).
- (3) Remove two screws (6).
- (4) Remove screw (7) and flat washer (8).
- (5) Remove two screws (9) and flat washers (10).
- (6) Remove screw (11)
- (7) Remove shroud (12) and cover (13).
- (8) Remove nut (14), washer (15), pulley (16), and screen (17). Pin (18) can be removed if necessary.
- (9) Install flywheel puller onto flywheel (19).

CAUTION

Striking the center of the engine shaft or end of flywheel puller T-handle against the engine shaft to loosen the flywheel will damage the engine.

- (10) Turn flywheel puller T-handle clockwise to remove flywheel (19). Striking the T-handle to rotate in a clockwise direction can help loosen flywheel and will not cause damage.
- (11) Remove flywheel (19) being careful not to loose key (20).
- (12) Remove five screws (21) and alternator magnet (22).

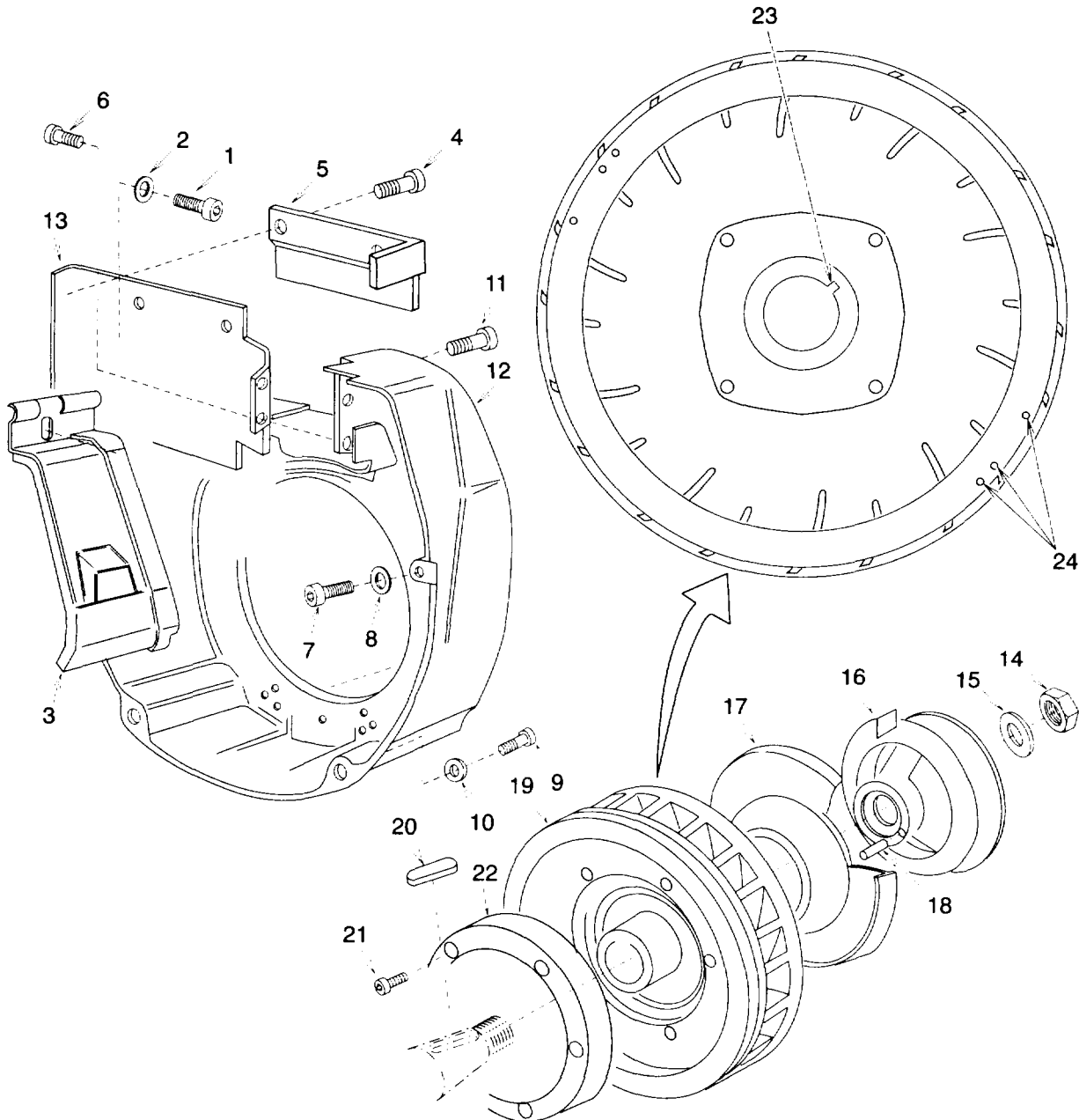

Figure 5-43. Flywheel

5-47. FLYWHEEL REPLACEMENT.-Continuedb. Installation.**CAUTION**

A new flywheel must have three punch marks in the same position as the old flywheel to allow proper timing of the engine.

NOTE

When installed, the indicator mark on the shroud will point to the furthest counterclockwise punch mark when the piston is at top dead center of the compression stroke. The other two punch marks should then be at 17° and 22° respectively from vertical.

- (1) Place the old flywheel (19) on top of new flywheel using the keyways (23) as reference to align them. Locate the three punch marks (24) on the old flywheel and make punch marks on the new flywheel in as close to the same position as possible.
- (2) Install alternator magnet (22) and five screws (21).
- (3) Install key (20) and flywheel (19).
- (4) Install pin (18) if removed. Install screen (17) and pulley (16) being careful to align pin with fly wheel (19).
- (5) Install washer (15) and nut (14). Torque nut to between 2393 ft lb and 2925 ft lb (3245 Nm and 3966 Nm).
- (6) Install cover (13) and shroud (12).
- (7) Install screw (11).
- (8) Install two flat washers (10) and screws (9).
- (9) Install flat washer (8) and screw (7).
- (10) Install two screws (6).
- (11) Install cover (5) and two screws (4).
- (12) Install cylinder casing (3), flat washer (2), and screw (1).

NOTE**FOLLOW-ON MAINTENANCE:**

Close front door.

Close left side door.

Connect battery (para 4-35) and put unit back into service.

5-48. ALTERNATOR REPLACEMENT.

This task covers:
a. Removal**b. Installation****INITIAL SETUP**Materials/Parts:

Marker tags (2)
4, Appendix E

Equipment Conditions:

Flywheel removed (para 547).

a. Removal.

- (1) Remove five screws (1) and alternator magnet (2).
- (2) Remove two screws (3), flat washers (4), and safety plates (5).
- (3) Tag and disconnect wireleads (6) by removing two wire splices (7).
- (4) Remove four screws (8) and alternator coil (9).

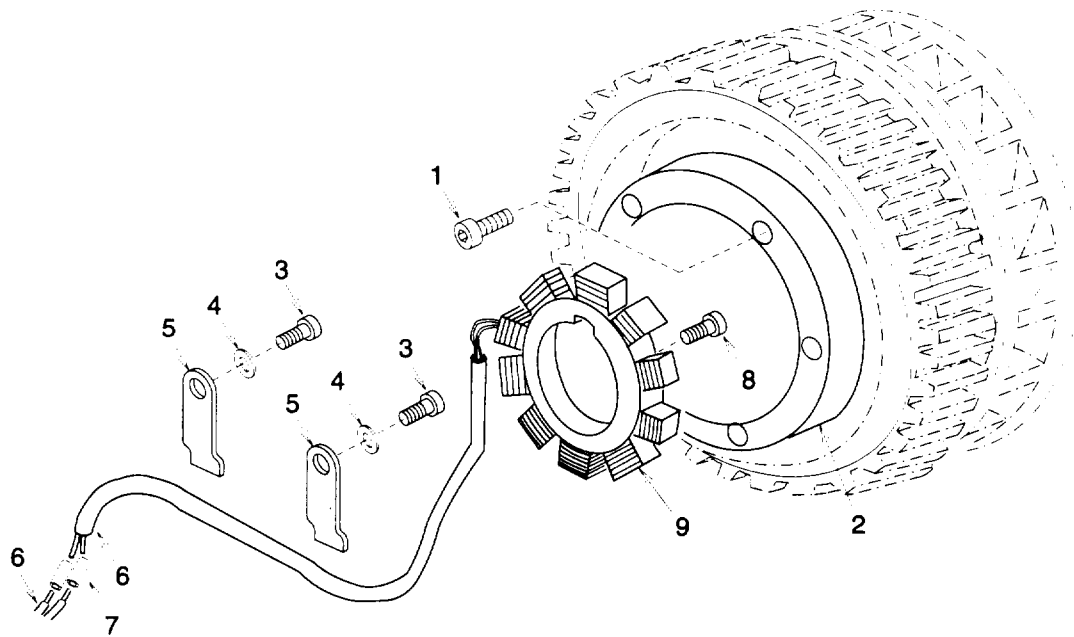

Figure 5-44. Alternator

5-48. ALTERNATOR REPLACEMENT.-Continued

b. Installation.

- (1) Install alternator coil (9) and secure with four screws (8).
- (2) Route alternator coil (9) leads as necessary and install two safety plates (5), flat washers (4), and screws (3).
- (3) Using tags and wiring diagram (fig. 1-4), connect wire leads (6) (para 4-20). Remove tags.
- (4) Install alternator magnet (2) and secure with five screws (1).

NOTE

**FOLLOW-ON MAINTENANCE:
Install flywheel (para 5-47).**

5-49. ENGINE AND COMPRESSOR BASE REPLACEMENT.

This task covers:

a. Removal

b. Installation

INITIAL SETUP

Materials/Parts:

- Lock Washers (2)
12, Appendix G
- Self Locking Nuts (4)
10, Appendix G
- Lock Washers (8)
12, Appendix G

Equipment Conditions:

- Engine removed (para 4-61).
 - Compressor removed (para 5-40).
-

a. Removal.

- (1) Remove swivel bolt (1).
- (2) Remove four self locking nuts (2), flat washers (3), and two engine mount spacer plates (4). Discard self locking nuts.
- (4) Remove engine mount (5).
- (5) Remove eight nuts (6), lock washers (7), and four isolator mounts (8). Discard lock washers.
- (6) Remove engine and compressor base (9).

b. Installation.

- (1) Install engine and compressor base (9) into enclosure.
- (2) Install four isolator mounts (8), eight new lock washers (7), and nuts (6).
- (3) Install engine mount (5).

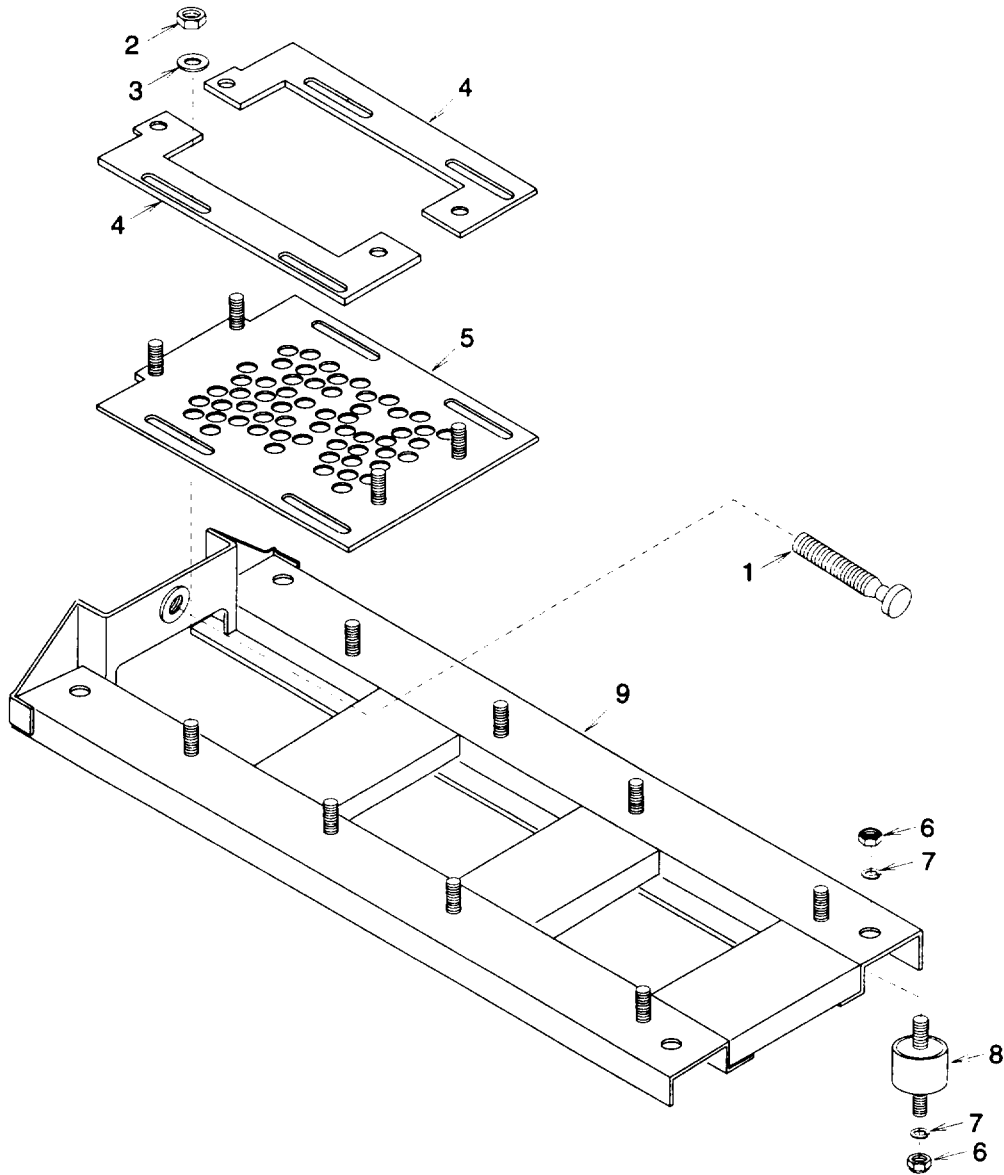

Figure 5-45. Engine and Compressor Base

5-49. ENGINE AND COMPRESSOR BASE REPLACEMENT.-Continued

- (4) Install two engine mount spacer plates (4), four flat washers (3), and new self locking nuts (2).
- (5) Install swivel bolt (1).

NOTE

FOLLOW-ON MAINTENANCE:
Install engine (para 4-61).
Install compressor (para 5-40).

5-50. SIDE DOORS REPLACEMENT.

This task covers:

a. Removal**b. Installation****INITIAL SETUP****Materials/Parts:**

Rivets (24)
 58, Appendix G
 Rivets (24)
 59, Appendix G

Equipment Conditions:

Refrigeration unit shut down (para 2-7) and battery disconnected (para 4-35).
 Barrel bolt clips removed (para 4-17).

a. Removal.

- (1) Remove twelve rivets (1), and right side door (2).
- (2) Remove twelve rivets (3), two hinges (4), and four bumpers (5).
- (3) Remove twelve rivets (6), and left side door (7).
- (4) Remove twelve rivets (8), two hinges (9), and four bumpers (10).

b. Installation.

- (1) Install four bumpers (10), two hinges (9) and secure with twelve rivets (8).
- (2) Install left side door (7) and secure using twelve rivets (6).
- (3) Install four bumpers (5), two hinges (4), and secure with twelve rivets (3).
- (4) Install right side door (2) and secure using twelve rivets (1).

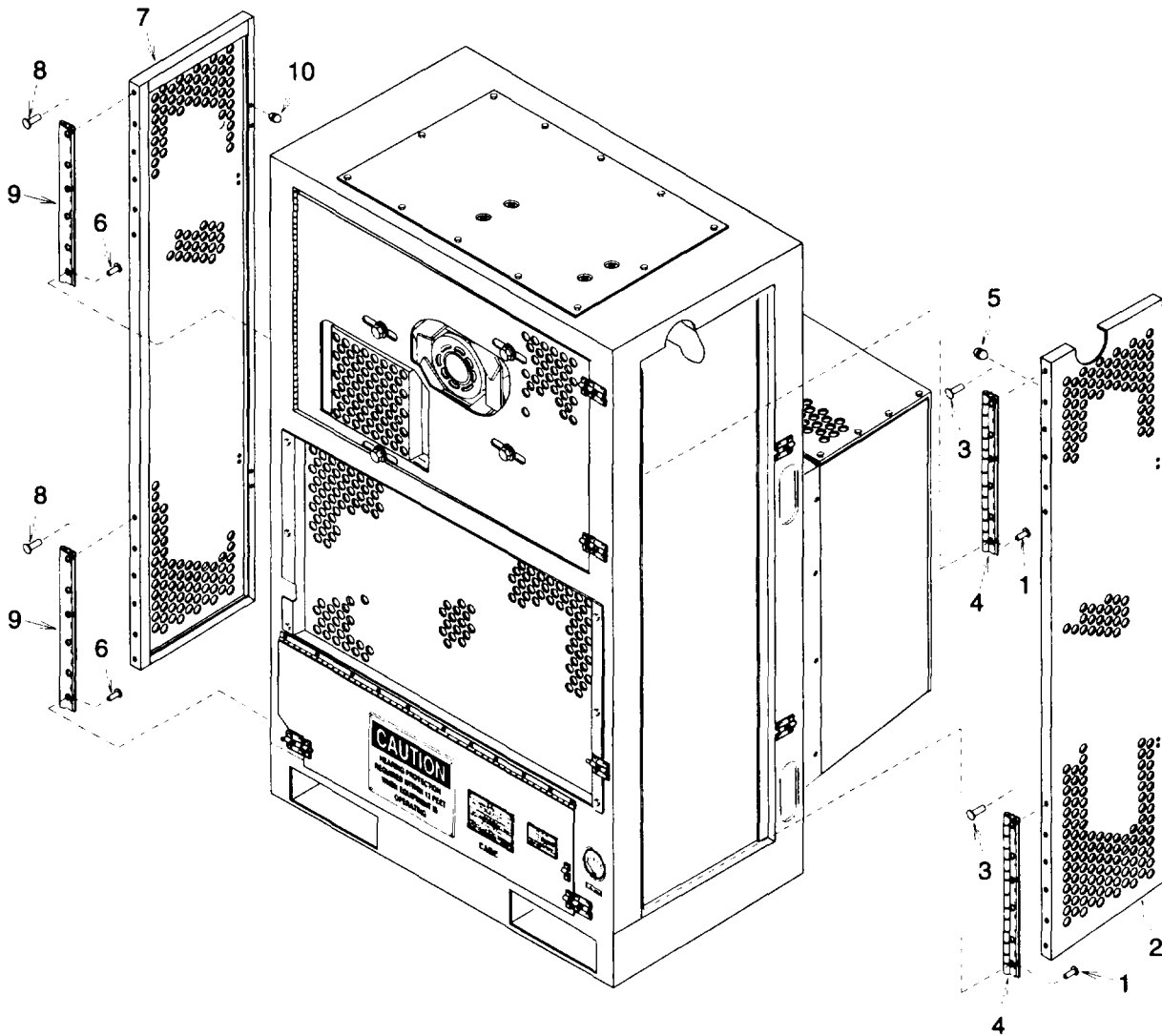

Figure 5-46. Left and Right Side Doors

NOTE

FOLLOW-ON MAINTENANCE:
 Install barrel bolt clips (para 4-17).
 Connect battery (para 4-35) and put unit back into service.

5-51. FRONT DOOR REPAIR.

This task covers:**a. Removal****b. Installation**

INITIAL SETUP**Materials/Parts:**

Rivets (9)
58, Appendix G
Rivets (9)
59, Appendix G
Lock Washers (4)
2, Appendix G

Equipment Conditions:

Refrigeration unit shut down (para 2-7) and battery disconnected (para 4-35).
Barrel bolt clips removed (para 4-17).

a. Removal.**NOTE****Repair is limited to replacement of damaged parts.**

- (1) Remove nine rivets (1), and door (2).
- (2) Remove nine rivets (3) and hinge (4).
- (3) Remove four screws (5), lock washers (6), flat washers (7) and slide plate (8). Discard lock washers.
- (4) Remove four bumpers (9).

b. Installation.**NOTE****Repair is limited to replacement of damaged parts.**

- (1) Install four bumpers (9).
- (2) Install slide plate (8), four flat washers (7), new lock washers (6), and screws (5).
- (3) Install hinge (4) using nine rivets (3).
- (4) Install door (2) using nine rivets (1).

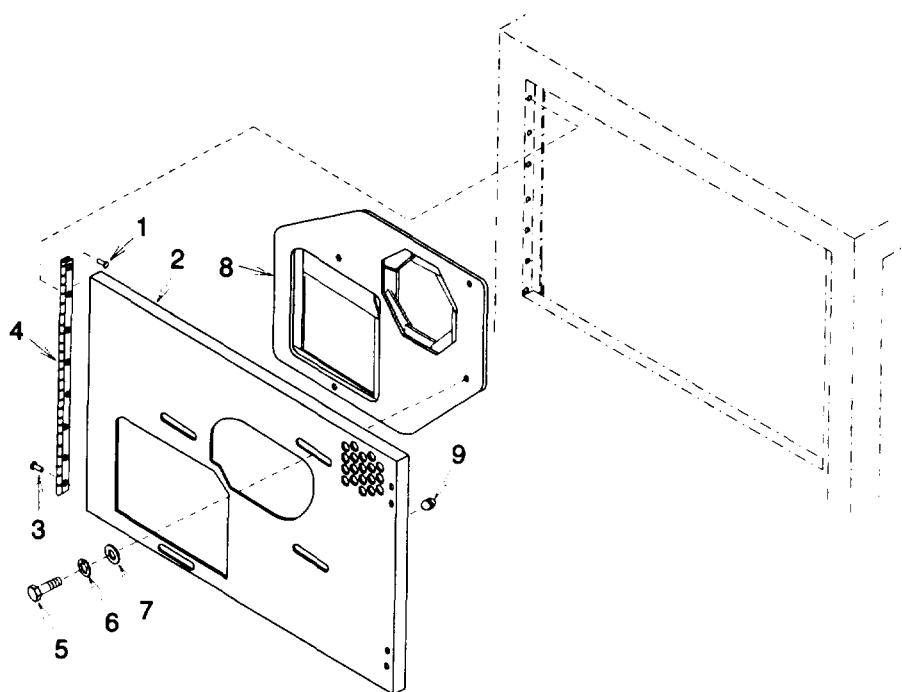

Figure 5-47. Front Door

NOTE

FOLLOW-ON MAINTENANCE:
 Install barrel bolt clips (para 4-17).
 Connect battery (para 4-35) and put unit back into service.

5-52. HOUSING REPAIR.

This task covers: Repair

INITIAL SETUP**Equipment Conditions:**

Refrigeration unit shut down (para 2-7) and battery disconnected (para 4-35).

General Safety Instructions:**WARNING**

Exposed rotating parts are used in the refrigeration unit. Personal injury can result if battery is connected.

Repair.**NOTE**

Repair to housing at this maintenance level is limited to replacement of any damaged rivets or blind rivet nuts.

- (1) Drill through rivet or blind rivet nut using drill bit slightly smaller than rivet diameter.
- (2) Remove any remaining rivet material.

NOTE**FOLLOW-ON MAINTENANCE:**

Connect battery (para 4-35) and put unit back into service.

CHAPTER 6

GENERAL SUPPORT MAINTENANCE INSTRUCTIONS

6-1. GENERAL.

The only item authorized by the Maintenance Allocation Chart (MAC) to the general support maintenance level is welding repair to the housing. However, general support maintenance may be called upon to perform any or all of the MAC items listed for unit and direct support maintenance for rehabilitation or overhaul of the refrigeration unit.

6-2. HOUSING REPAIR.

This task covers:

a. Repair

INITIAL SETUPEquipment Conditions:

Refrigeration unit shut down (para. 2-7) and battery disconnected (para. 4-35).

Tools:

Torch Set
1, Section III, Appendix B

General Safety Instructions:**WARNING**

Rotating parts are used in the refrigeration unit. Personal injury can result if battery is connected.

Repair.

- (1) Disassemble refrigeration unit as necessary and make repairs as indicated.
- (2) Repair any minor sheet metal dents and bent edges by straightening using common sheet metal repair procedures.
- (3) Weld any cracks or breaks in frame members or welds per MIL-B-7883.
- (4) Touch-up any painted surfaces per TM 43-0139.
- (5) Assemble refrigeration unit as necessary to return to service.

6-1/(6-2 blank)

APPENDIX A

REFERENCES

A-1. SCOPE.

This appendix list all forms, field manuals, and technical manuals referenced in this manual.

A-2. FORMS.

Recommended Changes to Publications..... DA Form 2028

Recommended Changes to Equipment Technical Manuals..... DA Form 2028-2

Product Quality Deficiency Report Standard Form 368

Log Book..... DA Form 2408-9

Equipment Inspection and Maintenance Worksheet..... DA Form 2404

A-3. FIELD MANUALS.

NBC Contamination Avoidance FM 3-3

NBC Protection FM 3-4

NBC Decontamination FM 3-5

A-4. TECHNICAL MANUALS.

Destruction of Army Material to Prevent Enemy Use TM 750-244-3

Unit, Direct Support, and General Support Maintenance
Repair Parts and Special Tools List..... TM 9-4110-255-24P

A-5. MISCELLANEOUS PUBLICATIONS.

Army Logistics Readiness and Sustainability AR 700-138

Army Maintenance Management System (TAMMS) DA Pam 738-750

Expendable Items
(Except Medical Class V, Repair Parts and Heraldic Items) CTA 50-970

Army Medical Department Expendable/Durable Items..... CTA 8-100

Methods of Preservation MIL-P-116

Crates, Wood, Open And Covered..... MIL-C-52950

A-6. WARRANTY TECHNICAL BULLETIN.

Refrigeration Unit, Mechanical, Panel Mounted for Refrigerator,
Prefabricated, Panel Type, Diesel Engine Driven,
5,000 BTU Model F5000RD TB 9-4110-255-24

APPENDIX B

MAINTENANCE ALLOCATION CHART

SECTION I INTRODUCTION

B-1. THE ARMY MAINTENANCE SYSTEM MAC.

a. This introduction (section I) provides a general explanation of all maintenance and repair functions authorized at various maintenance levels under the standard Army Maintenance System concept.

b. The Maintenance Allocation Chart (MAC) in Section II designates overall authority and responsibility for the performance of maintenance functions on the refrigeration unit. The application of the maintenance functions to the end item or component will be consistent with the capacities and capabilities of the designated maintenance levels, which are shown on the MAC in column (4) as:

Unit - Includes two subcolumns, C (operator/crew) and O (unit) maintenance.

Direct Support - Includes an F subcolumn

General support - Includes an H subcolumn.

Depot - Includes a D subcolumn.

c. Section III lists the tools and test equipment (both special tools and common tool sets) required for each maintenance function as referenced from Section II.

d. Section IV contains supplemental instructions and explanatory notes for a particular maintenance function.

B-2. MAINTENANCE FUNCTIONS.

Maintenance functions will be limited to and defined as follows:

a. Inspect. To determine the serviceability of an item by comparing its physical, mechanical and/or electrical characteristics with established standards through examination (e.g., by sight, sound, or feel).

b. Test. To verify serviceability by measuring the mechanical, pneumatic, hydraulic, or electrical characteristics of an item and comparing those characteristics with prescribed standards.

c. Service. Operations required periodically to keep an item in proper operating condition, e.g., to clean (includes decontaminate when required), to preserve, to drain, to paint, or to replenish fuel, lubricants, chemical fluids, or gases.

d. Adjust. To maintain or regulate, within prescribed limits, by bringing into proper position, or by setting the operating characteristics to specified parameters.

e. Aline. To adjust specified variable elements of an item to bring about optimum or desired performance.

B-2. MAINTENANCE FUNCTIONS . - Continued

f. Calibrate. To determine and cause corrections to be made or to be adjusted on instruments or test, measuring, and diagnostic equipment used in precision measurement. Consists of comparisons of two instruments, one of which is a certified standard of known accuracy, to detect and adjust any discrepancy in the accuracy of the instrument being compared.

g. Remove/Install. To remove and install the same item when required to perform service or other maintenance functions. Install may be the act of emplacing, seating, or fixing into position a spare, repair part, or module (component or assembly) in a manner to allow the proper functioning of an equipment or system.

h. Replace. To remove an unserviceable item and install a serviceable counterpart in its place. "Replace" is authorized by the MAC and assigned maintenance level is shown as the 3d position code of the SMR code.

i. Repair. The application of maintenance services¹, including fault location/troubleshooting², removal/installation, and disassembly/assembly³ procedures, and maintenance actions⁴ to identify troubles and restore serviceability to an item by correcting specific damage, fault, malfunction, or failure in a part, subassembly, module (component or assembly), end item, or system.

j. Overhaul. That maintenance effort (service/action) prescribed to restore an item to a completely serviceable/operational condition as required by maintenance standards in appropriate technical publications (i.e., DMWR). Overhaul is normally the highest degree of maintenance performed by the Army. Overhaul does not normally return an item to like new condition.

k. Rebuild. Consists of those services/actions necessary for the restoration of unserviceable equipment to a like new condition in accordance with original manufacturing standards. Rebuild is the highest degree of material maintenance applied to Army equipment. The rebuild operation includes the act of returning to zero those age measurements (e.g., hours/miles) considered in classifying Army equipment/components.

B-3. EXPLANATION OF COLUMNS IN THE MAC, SECTION II .

a. Column 1, Group Number. Column 1 lists functional group code numbers, the purpose of which is to identify maintenance significant components, assemblies, subassemblies, and modules with the next higher assembly.

b. Column 2, Component/Assembly. Column 2 contains the names of components, assemblies, subassemblies, and modules for which maintenance is authorized.

c. Column 3, Maintenance Functions. Column 3 lists the functions to be performed on the item listed in column 2. (For detailed explanation of these functions, see paragraph B-2.)

¹Services - Inspect, test, service, adjust, align, calibrate, and/or replace.

²Fault location/troubleshooting - The process of investigating and detecting the cause of equipment malfunctioning; the act of isolating a fault within a system or unit under test (UUT).

³Disassembly/assembly - The step-by-step breakdown (taking apart) of a spare/functional group coded item to the level of its least component, that is assigned an SMR code for the level of maintenance under consideration (e.g., identified as maintenance significant).

⁴Actions - Welding, grinding, riveting, straightening, facing, machining, and/or resurfacing.

B-3. EXPLANATION OF COLUMNS IN THE MAC, SECTION II. - Continued

d. Column 4, Maintenance Level. Column 4 specifies each level of maintenance authorized to perform each function listed in column 3, by indicating work time required (expressed as man-hours in whole hours or decimals) in the appropriate subcolumn. This work-time figure represents the active time required to perform that maintenance function at the indicated level of maintenance. If the number or complexity of the tasks within the listed maintenance function vary at different maintenance levels, appropriate work-time figures are to be shown for each level. The work-time figure represents the average time required to restore an item (assembly, subassembly, component, module, end item, or system) to a serviceable condition under typical field operating conditions. This time includes preparation time (including any necessary disassembly/assembly time), troubleshooting/fault location time, and quality assurance time in addition to the time required to perform the specific tasks identified for the maintenance functions authorized in the maintenance allocation chart. The symbol designations for the various maintenance levels are as follows:

- C Operator or Crew Maintenance
- O Unit Maintenance
- F Direct Support Maintenance
- H General Support Maintenance
- D Depot Maintenance

e. Column 5, Tools and Equipment Reference Code Column 5 specifies, by code, those common tool sets (not individual tools) common, TMDE, and special tools, special TMDE, and special support equipment required to perform the designated function. Codes are keyed to tools and test equipment in section III.

f. Column 6, Remarks. When applicable, this column contains a letter code, in alphabetical order, which is keyed to the remarks contained in Section IV.

⁵This maintenance level is not included in Section II, column (4) of the Maintenance Allocation Chart. Functions to this level of maintenance are identified by a work-time figure in the "H" column of Section II, column (4), and an associated reference code is used in the Remarks column (6). This code is keyed to Section IV, Remarks, and the SRA complete repair application is explained there.

B-4. EXPLANATION OF COLUMNS IN TOOL AND TEST EQUIPMENT REQUIREMENTS, SECTION III.

- a. Column 1, Reference Code. The tool and test equipment reference code correlates with a code used in the MAC, Section II, Column 5.
- b. Column 2, Maintenance Level. The lowest level of maintenance authorized to use the tool or test equipment.
- c. Column 3, Nomenclature. Name or identification of the tool or test equipment.
- d. Column 4, National Stock Number. The National Stock Number of the tool or test equipment.
- e. Column 5, Tool Number. The manufacturer's part number or type number.

B-5. EXPLANATION OF COLUMNS IN REMARKS, SECTION IV.

- a. Column 1, Remarks Code. The code recorded in column 6, Section II.
- b. Column 2, Remarks. This column lists information pertinent to the maintenance function being performed as indicated in the MAC, Section II.

SECTION II MAINTENANCE ALLOCATION CHART FOR REFRIGERATION UNIT

(1) Group Number	(2) Component/ Assembly	(3) Maint. Function	(4) MAINTENANCE CATEGORY					(5) Tools and Equipment	(6) Remarks
			Unit		Direct Support	General Support	Depot		
			C	O	F	H	D		
00	REFRIGERATION UNIT								
01	PANELS & GUARDS								
	Panels	Inspect Repair Replace	0.1		1.0			1 1	A
	Guards	Inspect Replace	0.1	0.5				1	
	Bolts, Barrel	Inspect Service Replace	0.1	0.1 1.0				1 1	
	Bolt Assembly, Unit Mounting	Inspect Replace	0.1	0.5				1	
02	ELECTRICAL AND CONTROL								
	Wires, Cables, & Harnesses	Inspect Test Repair Replace		0.5 0.5 1.0 2.0				1 1 1, 3 1, 3	
	Circuit Breaker	Inspect Test Replace		0.1 0.5 1.0				1 1 1	
	Lamp, Miniature	Inspect Test Replace		0.1 0.5 1.0				1 1 1	
	Fuses	Inspect Test Replace		0.1 0.5 0.2				1 1 1	
	Relays, Control	Inspect Test Replace		0.1 0.5 1.0				1 1 1,3	
	Relays, Time Delay	Inspect Test Replace		0.1 0.5 1.0				1 1 1, 3	
	Hourmeter	Inspect Test Replace		0.1 0.5 1.0				1 1 1	

(1) Group Number	(2) Component/ Assembly	(3) Maint. Function	(4) MAINTENANCE CATEGORY					(5) Tools and Equipment	(6) Remarks
			Unit		Direct Support	General Support	Depot		
			C	O	F	H	D		
02 - Cont	Ammeter	Inspect		0.1				1	
		Test		0.5				1	
		Replace		1.0				1	
	Switch, Toggle	Inspect		0.1				1	
		Test		0.5				1	
		Replace		1.0				1	
	Timer, Defrost	Inspect		0.1				1	
		Test		0.5				1	
		Replace		1.0				1	
	Thermostat, Remote Bulb	Inspect		0.1				1	
		Test		0.5				1	
		Replace		1.0				1	
	Switch, Engine Speed	Inspect		0.1				1	
		Replace		1.0				1	
	Transformer, Control	Inspect		0.1				1	
		Test		0.5				1	
		Replace		1.0				1	
	Temperature Gage (Thermometer)	Inspect	0.1						
Test			1.0				1		
Replace			0.5				1		
Solenoid, Continuous Duty	Inspect		0.1				1		
	Test		0.5				1		
	Replace		1.0				1		
Battery	Inspect	0.1							
	Test		0.3				1		
	Replace		0.3				1		
Switch, Temperature (Defrost Termination)	Inspect		0.1				1		
	Test		0.5				1		
	Replace		1.0				1		
Switch, Push (Door)	Inspect	0.1							
	Test		0.5				1, 3		
	Replace		1.0				1, 3		
03 POWER TRANSMISSION- /AIR HANDLING V-Belts	Inspect	0.1							
	Adjust		0.5				1		
	Replace		0.5				1		

(1) Group Number	(2) Component/ Assembly	(3) Maint. Function	(4) MAINTENANCE CATEGORY					(5) Tools and Equipment	(6) Remarks	
			Unit		Direct Support	General Support	Depot			
			C	O	F	H	D			
03 - Cont	Pulley, Engine	Inspect Replace	0.1	6.0				1		
	Pulley, Compressor	Inspect Replace	0.1		6.0			1		
	Pulley, Idler	Inspect Replace	0.1	1.0				1		
	Fan, Condenser	Inspect Replace		0.5 1.0				1 1		
	Fan, Evaporator	Inspect Replace		0.5 0.5				1 1		
	Shaft, Fan Drive	Inspect Replace	0.1		4.0			1, 4, 5, 6		
	Bearings, Flange	Inspect Service Replace		0.1 0.2 2.0				1 1 1		
	Clutch, Fan	Inspect Test Replace	0.1		0.5 1.5			1 1		
	04	REFRIGERATION SYSTEM								
		Dehydrator	Inspect Replace	0.1		3.0			4, 5	
Gages, Pressure		Inspect Replace	0.1		3.0			4, 5		
Strainer		Inspect Replace	0.1		3.0			4, 5		
Valves, Isolation		Inspect Replace	0.1		3.0			4, 5		
Receiver		Inspect Replace	0.1		3.0			4, 5		
Condenser Coil		Inspect Service Replace		0.1 1.0	4.0			1 1, 2 4, 5, 6		
Valves, Pressure Regulator		Inspect Replace	0.1		3.0			4, 5, 6		
Valve, Check		Inspect Replace	0.1		8.0			4, 5, 6		

(1) Group Number	(2) Component/ Assembly	(3) Maint. Function	(4) MAINTENANCE CATEGORY					(5) Tools and Equipment	(6) Remarks
			Unit		Direct Support	General Support	Depot		
			C	O	F	H	D		
04 - Cont	Hose Assemblies, Metal	Inspect Replace	0.1		3.0			4, 5, 6	
	Accumulator	Inspect Replace	0.1		3.0			4, 5, 6	
	Valves, Solenoid	Inspect	0.1					1	
		Test		0.3					
		Repair Replace		1.0	3.5 3.5			4,5 4, 5	B
	Valves, Stop	Inspect	0.1						
		Replace			3.0			4, 5, 6	
	Indicator, Sight	Inspect	0.1						
		Replace			3.0			4, 5	
	Switches, Pressure	Inspect	0.1						
		Replace			3.0			4, 5	
	Heat Exchanger	Inspect		0.1				1	
		Replace			3.0			4, 5, 6	
Valve, Expansion	Inspect		0.1				1		
	Replace			3.0			4, 5		
Evaporator Coil	Inspect		0.1				1		
	Service		1.0				1, 2		
	Replace			4.0			4, 5, 6		
Compressor	Inspect	0.1							
	Service			0.5			4, 5		
	Test			0.5			4, 5		
	Repair			10.0			4, 5, 6		
	Replace			6.0			4, 5, 6		
Tubing and Fittings	Inspect		1.0				1		
	Test			1.0			4, 5, 6		
	Repair			1.0			4, 5, 6		
	Replace			3.0			4, 5, 6		
05	ENGINE								
Oil Filter	Inspect	0.2							
	Service Replace		0.2 0.2				1 1		
Air Cleaner	Inspect	0.1							
	Service Replace		0.3 0.3				1 1		

(1) Group Number	(2) Component/ Assembly	(3) Maint. Function	(4) MAINTENANCE CATEGORY					(5) Tools and Equipment	(6) Remarks
			Unit		Direct Support	General Support	Depot		
			C	O	F	H	D		
05 - Cont	Muffler	Inspect Replace	0.1	0.8				1	
	Switch, Engine Oil Pressure	Inspect Test Replace	0.1	0.5 1.0				1 1	
	Switch, Engine Temperature	Inspect Test Replace		0.1 0.5 1.0				1 1	
	Solenoid, Fuel	Inspect Test Replace		0.1 0.5 1.0				1 1	
	Motor, Starting	Inspect Replace	0.1	0.5				1	
	Nozzle	Test Replace			1.0 1.0			1, 7, 10,11 1, 10, 11	
	Pump, Injection	Test Replace Adjust			1.0 1.0 1.0			1 1 1, 8	
	Fuel Filter	Inspect Service Replace	0.1	0.3 0.3				1 1	
	Voltage Regulator	Inspect Replace	0.1	0.5				1	
	Fuel Pump	Inspect Replace	0.5		1.0			1 1	
	Head, Cylinder	Inspect Test Replace Adjust	0.1		2.0 2.0 1.0			1 1 1, 12	
	Engine Oil Pump	Inspect Replace			1.0 2.0			1 1	
	Flywheel	Inspect Replace		1.0	4.0			1 1, 9	
	Alternator	Test Replace		1.0	4.0			1 1	

(1) Group Number	(2) Component/ Assembly	(3) Maint. Function	(4) MAINTENANCE CATEGORY					(5) Tools and Equipment	(6) Remarks	
			Unit		Direct Support	General Support	Depot			
			C	O	F	H	D			
05 - Cont	Glow Plug	Inspect		0.5				1		
		Test		0.5				1		
		Replace		0.5				1		
06	Engine	Inspect	0.1							
		Service		1.0				1		
		Repair		5.0	5.0			1	C	
06	FUEL	Replace		6.0				1		
		Hoses	Inspect	0.1						
			Repair		0.8				1	
Replace			0.3				1			
06	Filter, Fuel Line	Inspect	0.1							
		Service		0.5				1		
		Replace		0.5				1		
06	Fuel Gage	Inspect	0.1							
		Replace		0.5				1		
		Sending Unit	Inspect		0.1					1
Replace			2.5					1		
Fuel Tank	Inspect		0.1							
	Repair		0.8					1		
	Replace		2.0					1		
07	HOUSING	Inspect	0.1							
		Replace		1.0				1		
		Doors and Cover	Inspect	0.1						
Service			0.5					1		
Repair				1.0				1	A	
07	Housing	Replace			0.5				1	
		Inspect	0.1							
		Repair			6.0	6.0			1	D

SECTION III TOOL AND TEST EQUIPMENT REQUIREMENTS FOR REFRIGERATION UNIT

(1) Tool or Test Equipment Ref Code	(2) Maintenance Level	(3) Nomenclature	(4) National Stock Number	(5) Tool Number
<p>NOTE</p> <p>Standard tools and test equipment in the following kits are adequate to accomplish the maintenance functions listed in Section II:</p>				
1	O	Shop Equipment (1), Automotive Vehicle	4910-00-754-0654	SC 4910-95-CL-A74
2	O	Comb, Fin	5120-00-916-6197	
3	O	Heat Gun	3439-01-037-7268	
4	F	Tool Kit, Service, Refrigeration Unit	5180-00-597-1474	SC 5180-90-CL-N18
5	F	Recovery and Recycle Unit, Refrigerant	4130-01-338-2707	
6	F	Nitrogen Regulator	6680-00-503-1327	
7	F	Injector Test Bench		(62445) 773-6543 (A4521) 365.43
8	F	Fuel Delivery Sight	5120-01-413-8732	(62445) 773-6594 (A4521) 365.94
9	F	Flywheel Puller		(62445) 773-6502 (A4521) 365.02
10	F	Injector Extractor (Without Mechanical Puller)	5120-01-333-3140	(62445) 003-0536 (A4521) 305.36
11	F	Mechanical Puller (Use With Injector Extractor)	5120-01-247-6131	(62445) 003-0463 (A4521) 304.63
12	F	Valve Adjustment Tool	5120-01-410-8568	(62445) 773-6601 (A4521) 366.01

SECTION IV REMARKS FOR REFRIGERATION UNIT

Reference Code	Remarks
A	Repair is limited to replacement of damaged gaskets.
B	Repair at unit maintenance level is limited to replacement of electric coil.
C	Repair at unit maintenance level is limited to replacement of damaged components only.
D	Repair at direct support maintenance level is limited to replacement of damaged components.

B-11/(B-12 blank)

APPENDIX C**COMPONENTS OF END ITEM (COEI) AND BASIC ISSUE ITEMS (BII) LIST****SECTION I INTRODUCTION****C-1. SCOPE.**

This appendix lists components of the end item and basic issue items for the refrigeration unit to help you inventory the items for safe and efficient operation of the equipment.

C-2. GENERAL.

The Components of End Item (COEI) and Basic Issue Items (BII) Lists are divided into the following sections:

- a. Section II, Components of End Item. This listing is for information purposes only, and is not authority to requisition replacements. These items are part of the refrigeration unit. As part of the end item, these items must be with the end item whenever it is issued or transferred between property accounts. Items of COEI are removed and separately packaged for transportation or furnished to help you find and identify the items.
- b. Section III, Basic Issue Items. These essential items are required to place the refrigeration unit in operation, operate it, and to do emergency repairs. Although shipped separately packaged, BII must be with the refrigeration unit during operation and when it is transferred between property accounts. This list is your authority to request/requisition them for replacement based on authorization of the end item by the TOE/MTOE. Illustrations are furnished to help you find and identify the items.
- c. Explanation of Columns.
 - (1) Column (1), Illus Number, gives you the number of the item illustrated.
 - (2) Column (2), National Stock Number, identifies the stock number of the item to be used for requisitioning purposes.
 - (3) Column (3), Description and Usable On Code, identifies the Federal item name (in all capital letters) followed by a minimum description when needed. The last line below the description is the Commercial and Government Entity Code (CAGEC) (in parentheses) and the part number.
 - (4) Column (4), U/I (unit of issue), indicates how the item is issued for the National Stock Number shown in column two.
 - (5) Column (5), Qty Rqd, indicates the quantity required.

SECTION II COMPONENTS OF END ITEM

There are no loose or separate components supplied with this refrigeration unit.

SECTION III BASIC ISSUE ITEMS LIST

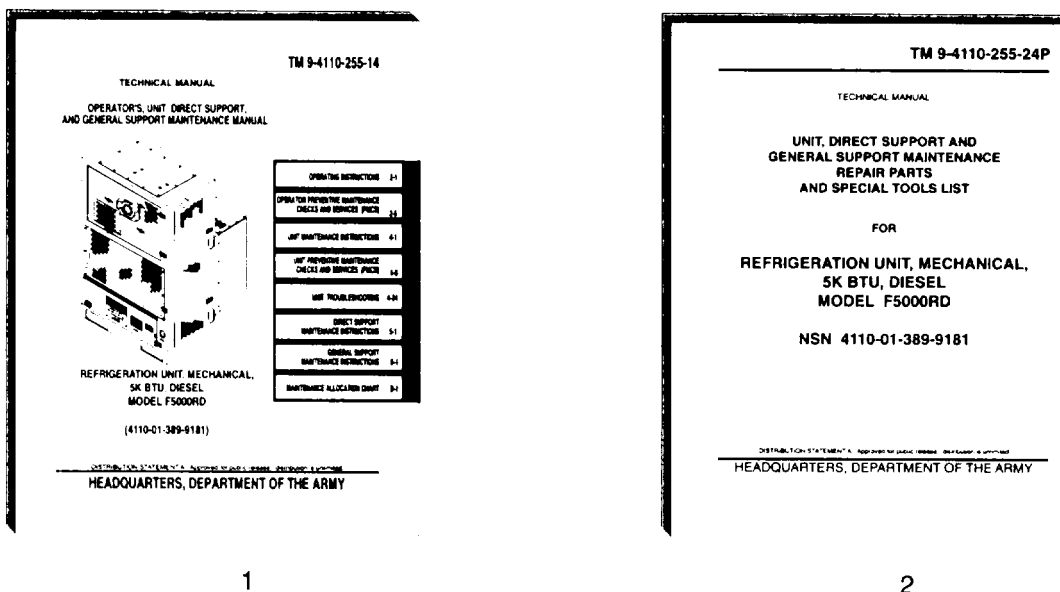

Figure C-1. Basic Issue Items

(1) Illus Number	(2) National Stock Number	(3) Description CAGEC and Part Number	(4) U/M	(5) Qty Rqd.
1		ARMY TECHNICAL MANUAL Operator's, Unit, Direct Support and General Support Maintenance for Refrigeration Unit, Mechanical 5K BTU Diesel, Model F5000RD TM 9-4110-255-14	EA	1
2		ARMY TECHNICAL MANUAL Unit, Direct Support and General Support Maintenance Repair Parts and Special Tools List for Refrigeration Unit, Mechanical, 5K BTU, Diesel Model F5000RD TM 9-4110-255-24P	EA	1

APPENDIX D

ADDITIONAL AUTHORIZATION LIST

There are no additional authorized items required for this refrigeration unit.

D-1/(D-2 blank)

APPENDIX E

EXPENDABLE AND DURABLE ITEMS LIST

SECTION I INTRODUCTION

E-1. SCOPE.

This appendix lists expendable and durable items you will need to maintain the refrigeration unit. This listing is for informational purposes only and is not authority to requisition the listed items. These items are authorized by CTA 50-970, expendable items (except Medical, Class V, Repair Parts, and Heraldic Items).

E-2. EXPLANATION OF COLUMNS.

- a. Column (1) - Item Number. This number is assigned to the entry in the listing for referencing when required.
- b. Column (2) - Level. This column identifies the lowest level of maintenance that requires the listed item.
 - C - Operator/Crew
 - O - Unit Maintenance
 - F - Direct Support Maintenance
 - H - General Support Maintenance
- c. Column (3) National Stock Number. This is the national stock number assigned to the item; use it to request or requisition the item.
- d. Column (4) Description. Indicates the federal item name and, if required a description to identify the item. The last line for each item indicates the Commercial and Government Entity Code (CAGEC) in parentheses followed by the part number.
- e. Column (5) Unit of Measure (U/M) Unit of Issue (U/I). This measure is expressed by a two character alphabetical abbreviation (e.g., EA, IN, PR). If the unit of measure differs from the unit of issue as shown in the Army Master Data File (AMDF) requisition the lowest unit of issue that will satisfy your requirements.

SECTION II EXPENDABLE AND DURABLE ITEMS LIST

(1) Item Number	(2) Level	(3) National Stock Number	(4) Description	(5) (U/M)/ (U/I)
1	O		Adhesive-Sealant, Silicone RTV MIL-A-46106, Type I	oz
2	O	5935-00-725-4153	Solder, Lead-Tin, QQ-S-571 Type SN60WRP2	
3	F	3439-00-640-3713	Flux, Brazing O-F-499, type B	oz
4	O	9905-00-537-8954	Marker Tag, MIL-T-12755	box
5	O		Tie Down Strap, (96906), MS3367-2-9	hd
6	O	5640-00-580-6276	Insulation Tape	roll
7	O		Tie Down Strap, (96906), MS3367-4-9	hd
8	O		Tie Down Strap, (96906), MS3367-5-9	hd
9	O	7920-00-205-1711	Wiping Rag	bl
10	O	9150-01-178-4725	Lubricating Oil, Engine, MIL-L-2104, OE/HDO-15/40	qt
11	O	9150-01-177-3988	Lubricating Oil, Engine, MIL-L-2104, OE/HDO-10	qt
12	O	9150-00-188-9864	Lubricating Oil, Engine, MIL-L-2104, OE/HDO-50	qt
13	O		Fuel, Diesel, VV-F-800, DF-2	bl
14	O		Fuel, Diesel, VV-F-800, DF-A	bl
15	O	7930-00-985-6911	Detergent (81349) MIL-D-16791	gl
16	O		Clamp, (81646), 6202	ea
17	O	9150-00-985-7316	Grease, Multipurpose MIL-G-23549	lb
18	O	3439-01-045-7940	Flux, Solder, Liquid, Rosin Base MIL-F-14256	qt
19	O	3040-00-644-0439	Adhesive, General Purpose,	pt
20	F		Acetone	gl

(1) Item Number	(2) Level	(3) National Stock Number	(4) Description	(5) (U/M)/ (U/l)
21	F		Methyl-Ethyl Ketone	gl
22	F	6830-00-292-0732	Nitrogen	cy
23	F		Brazing Alloy, Silver QQ-B-564, grade O, I or II	oz
24	F		Brazing Alloy, Silver QQ-B-564, grade III	oz
25	O	5350-00-192-5047	Abrasive Cloth	pg
26	F	6830-01-380-4960	Refrigerant, R134a	cy
27	F		Tape, Anti-Seize MIL-T-27730, Size 1	roll
28	F	9150-01-410-8972	Lubricating Oil, Refrigerant, Compressor, (2R128) SW-68	qt
29	O		Tie Down Strap, (96906), MS3367-7-9	hd
30	O		Lubricating Oil, Engine Preservative, MIL-L-21260, T930	qt
31	O		Oil Preservative, VV-L-800, T900	gl
32	O		Compound, MIL-C-16173	qt
33	O	8135-00-664-6958	Greaseproofed, Waterproof, Flexible Barrier Material, PP-C-843, Type II Class B	roll
34	O	7510-00-266-5006	Tape, Waterproof Packaging, PPP-T-60, Type IV	roll

APPENDIX F

ILLUSTRATED LIST OF MANUFACTURED ITEMS

SECTION I

F-1. SCOPE.

This appendix includes complete instructions for making items authorized to be manufactured or fabricated at unit, and direct support maintenance.

a. A part number index in alphanumeric order is provided for cross-referencing the part number of the item to be manufactured to the figure which covers fabrication criteria.

b. All bulk materials needed for manufacture of an item are listed by part number or specification number in a tabular list on the illustration.

c. All dimensions are given in inches with centimeters shown in parenthesis.

d. For fabrication information of electrical wires including lengths and markings, see Table 4-3.

SECTION II

F-2. MANUFACTURED ITEMS PART NUMBER LIST .

<u>Part Number</u>	<u>Figure Number</u>
12075-5-9375.....	F-1
12075-9-2750.....	F-1
12075-9-3350.....	F-1
12075-9-7313	F-1
12075-9-7500.....	F-1
12075-9-9750.....	F-1
12076-3-1000	F-2
12076-5-0875.....	F-2
12076-5-1375.....	F-2
12076-5-6750.....	F-2
12284-5-5000.....	F-3
12284-5-9750.....	F-3
12290-8-8000.....	F-4
148K0000-1/204	F-5
148K0000-1/205	F-6

F-2. MANUFACTURED ITEMS PART NUMBER LIST . - Continued

<u>Part Number</u>	<u>Figure Number</u>
148K0000-1/206.....	F-6
148K0000-1/232.....	F-7
148K0000-1/233.....	F-7
148K0018.....	F-8
148K0093-3.....	F-9
148K0113-1.....	F-3
148K0113-3.....	F-3
148K0113-5.....	F-3
148K0113-7.....	F-3
148K0113-9.....	F-10
148K0113-11.....	F-10
148K0113-13.....	F-11
148K0143.....	F-12
148K0144.....	F-13
148K0168.....	F-14
148K0169-1T.....	F-15
148K0170.....	F-1
148K0171.....	F-16
148K0172.....	F-1
148K0173.....	F-17
148K0174.....	F-18
148K0221.....	F-19
148K0222-1/T.....	F-20
148K0223-1/T.....	F-21
148K0224-1/T.....	F-22
148K0225-1/T.....	F-23
148K0226-1/T.....	F-24
148K0227.....	F-25
148K0228.....	F-26
148K0229.....	F-27
148K0230-1/T.....	F-28
148K0231-1/T.....	F-29
148K0232.....	F-30

<u>Part Number</u>	<u>Figure Number</u>
148K0233.....	F-31
148K0234.....	F-32
148K0239-1/3.....	F-3
148K0239-1/4.....	F-3
148K0240-1/3.....	F-1
148K0240-3/3.....	F-1
148K0244.....	F-3
148K0245.....	F-33
150K0096.....	F-3
150K0163-1.....	F-34
150K0165-5.....	F-34
150K0165-7.....	F-34
150K0165-11.....	F-34
150K0165-13.....	F-34
150K0185-1/1.....	F-35
150K0201-1 /1.....	F-35
150K0201-1/3.....	F-6
150K0206-3/3.....	F-36
150K0206-5/3.....	F-36
152K0194.....	F-37
51206-13.....	F-38
51206-25.....	F-38
51206-30.....	F-38
51206-36.....	F-38
8337032-4.....	F-39

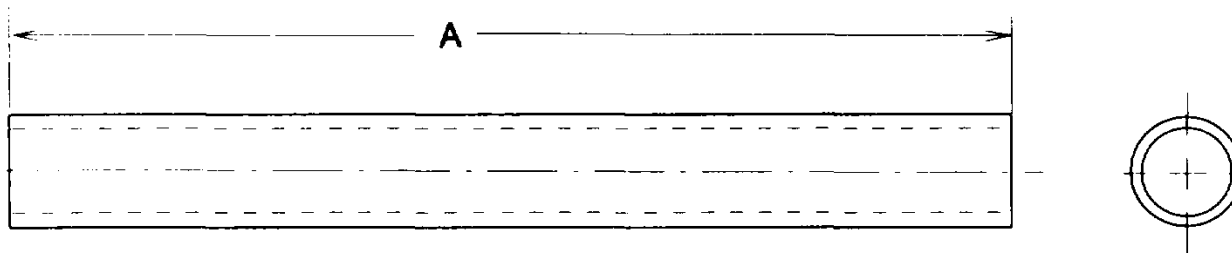

ITEM	PART NO.	DIM "A"	FABRICATE FROM
1	12075-5-9375	9.375 (23.813)	0.375 (.953) O.D. X 0.032 (0.081) WALL ASTM B280 COPPER TUBING
2	12075-9-2750	2.75 (6.99)	0.875 (2.223) O.D. X 0.045 (0.114) WALL ASTM B280 COPPER TUBING
3	12075-9-3350	3.35 (8.51)	0.875 (2.223) O.D. X 0.045 (0.114) WALL ASTM B280 COPPER TUBING
4	12075-9-7313	7.31 (18.57)	0.875 (2.223) O.D. X 0.045 (0.114) WALL ASTM B280 COPPER TUBING
5	12075-9-7500	7.50 (19.05)	0.875 (2.223) O.D. X 0.045 (0.114) WALL ASTM B280 COPPER TUBING
6	12075-9-9750	9.75 (24.77)	0.875 (2.223) O.D. X 0.045 (0.114) WALL ASTM B280 COPPER TUBING
7	148K0170	1.13 (2.87)	0.375 (.953) O.D. X 0.032 (0.081) WALL ASTM B280 COPPER TUBING
8	148K0172	1.25 (3.17)	0.625 (1.588) O.D. X 0.035 (0.089) WALL ASTM B280 COPPER TUBING
9	148K0240-1/3	100.00 (279.40)	0.125 (.318) O.D. X 0.030 (0.076) WALL ASTM B280 COPPER TUBING
10	148K0240-3/3	120.00 (304.80)	0.125 (.318) O.D. X 0.030 (0.076) WALL ASTM B280 COPPER TUBING

Figure F-1. Tube, Copper Straight, Various

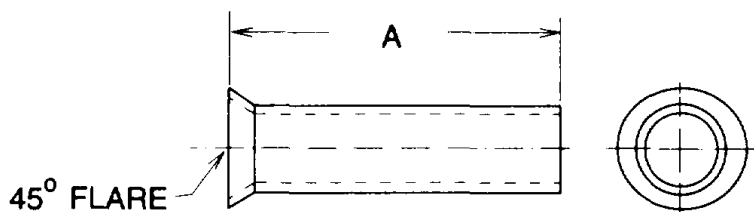

ITEM	PART NO.	DIM "A"	FABRICATE FROM
1	12076-3-1000	1.000 (2.540)	0.250 (0.635) O.D. X 0.030 (0.076) WALL ASTM B280 COPPER TUBING
2	12076-5-0875	0.875 (2.222)	0.375 (.953) O.D. X 0.032 (0.081) WALL ASTM B280 COPPER TUBING
3	12076-5-1375	1.375 (3.493)	0.375 (.953) O.D. X 0.032 (0.081) WALL ASTM B280 COPPER TUBING
4	12076-5-6750	7.750 (17.145)	0.375 (.953) O.D. X 0.032 (0.081) WALL ASTM B280 COPPER TUBING

Figure F-2. Tubing-Copper, Straight Flared, Various

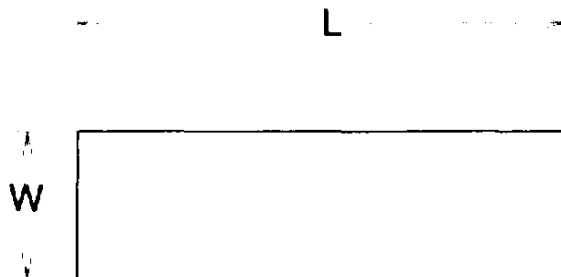

ITEM	PART NUMBER	W DIM	L DIM	FABRICATE FROM
1	12284-5-5000	50 (1.27)	5.00 (12.70)	ASTM D1056-2A2C2F2 0.125 (0.318) THICK RUBBER GASKET
2	12284-5-9750	50 (1.27)	6.75 (17.15)	ASTM D1056-2A2C2F2 0.125 (0.318) THICK RUBBER GASKET
3	1 50K0096	50 (1.27)	6.84 (17.37)	ASTM D1056-2A2C2F2 0.125 (0.318) THICK RUBBER GASKET
4	148K13-1	56 (1.42)	8.68 (22.05)	ASTM D1056-2A2C2F2 0.125 (0.318) THICK RUBBER GASKET
5	148K0113-3	56 (1.42)	27.87 (70.79)	ASTM D1056-2A2C2F2 0.125 (0.318) THICK RUBBER GASKET
6	148K0113-5	50 (1.42)	3.06 (7.77)	ASTM D1056-2A2C2F2 0.125 (0.318) THICK RUBBER GASKET
7	148K0113-7	56 (1.42)	31.87 (80.95)	ASTM D1056-2A2C2F2 0.125 (0.318) THICK RUBBER GASKET
8	148K0239-1/3	50 (1.27)	4.88 (12.40)	ASTM D1056-2A2C2F2 0.125 (0.318) THICK RUBBER GASKET
9	148K0239-1/4	50 (1.27)	6.50 (16.51)	ASTM D1056-2A2C2F2 0.125 (0.318) THICK RUBBER GASKET
10	148K0244	1.00 (2.54)	5.00 (12.70)	ASTM D735 0.063 (0.160) THICK NEOPRENE GASKET

Figure F-3. Gasket, Various

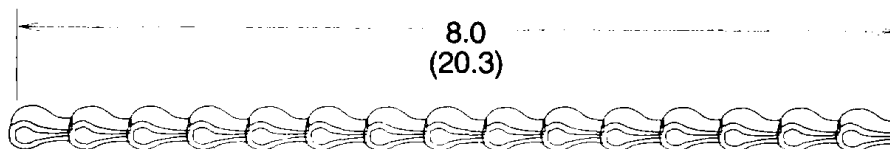

NOTE

- 1. FABRICATE FROM NUMBER 8 SASH CHAIN

Figure F-4. Chain, Sash, Part Number 12290-8-8000

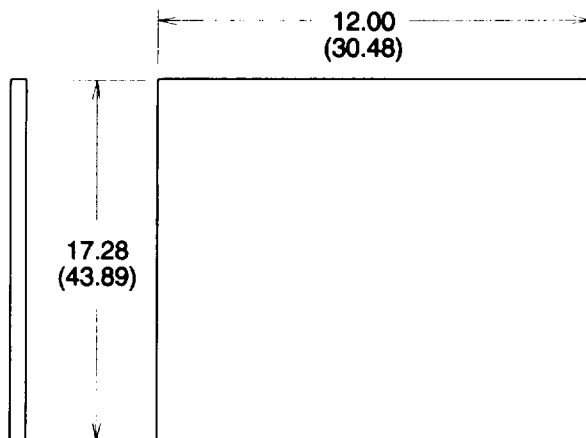

NOTE

1. FABRICATE FROM (97403) 13225E8562 INSULATION SHEET

Figure F-5. Insulation, Sound and Temperature, Part Number 148K0000-1/204

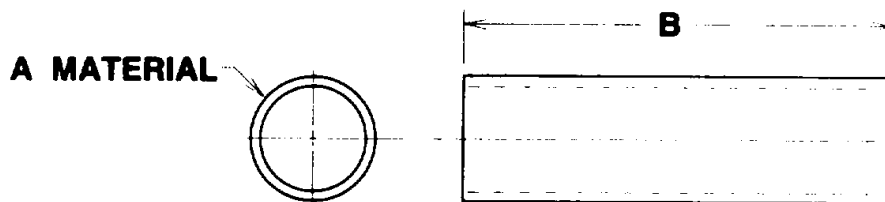

ITEM	PART NUMBER	FABRICATE FROM MATERIAL A	B LENGTH
1	148K0000-1/205	M23053/5-106-9 INSULATION, SLEEVING, HEAT SHRINKABLE	1.50 (3.81)
2	148K0000-1/206	M23053/5-107-9 INSULATION, SLEEVING, HEAT SHRINKABLE	1.50 (3.81)
3	150K0201-1/3	M23053/5-107-0 INSULATION, SLEEVING, HEAT SHRINKABLE	4.00 (10.16)

Figure F-6. Insulation Sleeving

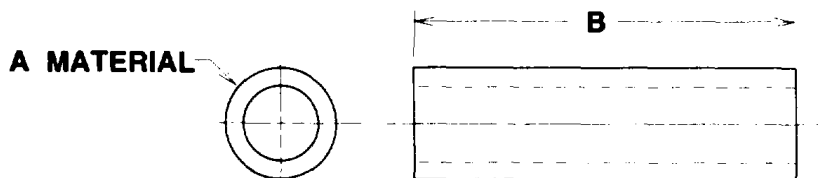

ITEM	PART NUMBER	FABRICATE FROM MATERIAL	A B LENGTH
1	148K0000-1/232	MIL-P-15280, FORM T, 1.38 ID (3.51) X .50 (1.27) WALL INSULATION, TUBING	AS REQD
2	148K0000-1/233	MIL-P-15280, FORM T, 0.63 ID (1,60) X .50 (1.27) WALL INSULATION, TUBING	AS REQD

Figure F-7. Insulation Tubing, Part Number 148K0000-1/233

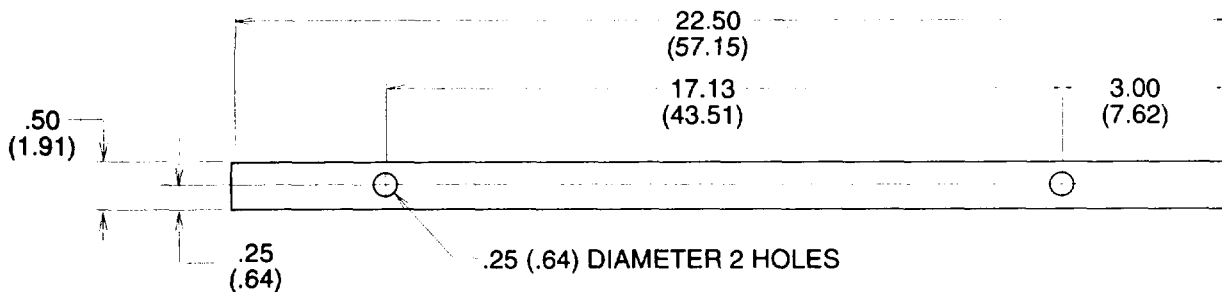

NOTE
 1. FABRICATE FROM ASTM D1056-2A2C2F2
 0.125 (0.318) THICK RUBBER GASKET

Figure F-8. Gasket, Control Box, Top, Part Number 148K0018

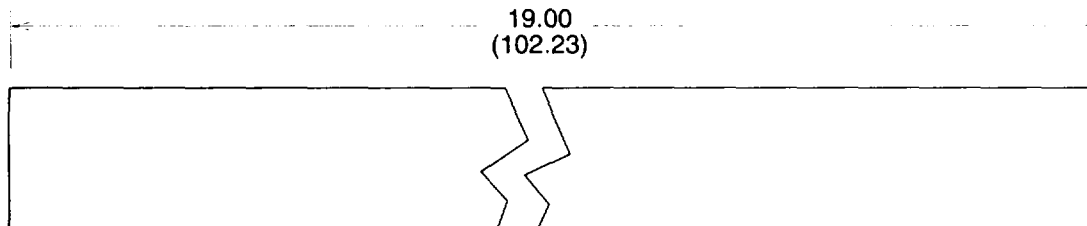

NOTE
 1. FABRICATE FROM (70470) 572320 WEBBING FABRIC

Figure F-9. Webbing Fabric, Part Number 148K0093-3

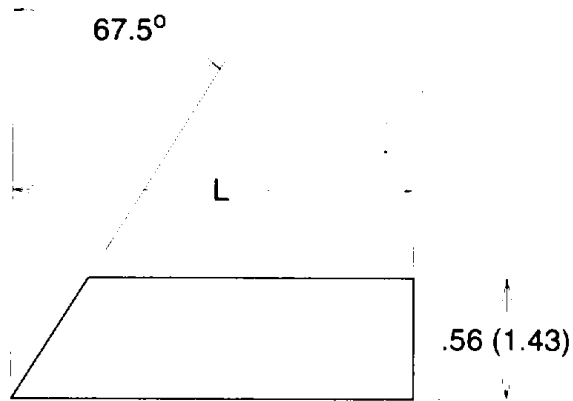

ITEM	PART NUMBER	L DIM	FABRICATE FROM
1	1 48KO1 13-9	1.88 (4.78)	ASTM D1056-2A2C2F2 0.125 (0.318) THICK RUBBER GASKET
2	1 148KO113-11	5.18 (13.16)	ASTM D1056-2A2C2F2 0.125 (0.318) THICK RUBBER GASKET

Figure F-10. Gasket, Control Box Cover

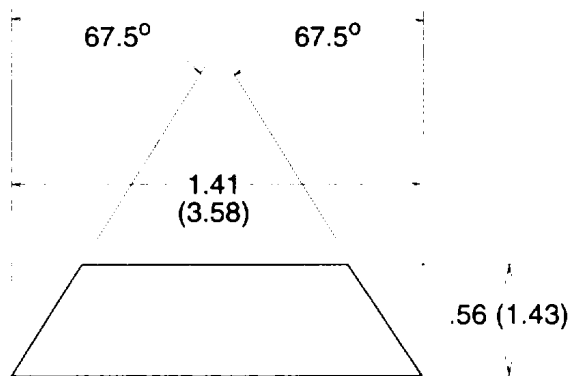

NOTE

- FABRICATE FROM ASTM D1056-2A2C2F2
0.125 (0.318) THICK RUBBER GASKET

Figure F-11. Gasket, Control Cover, Part Number 148K0113-13

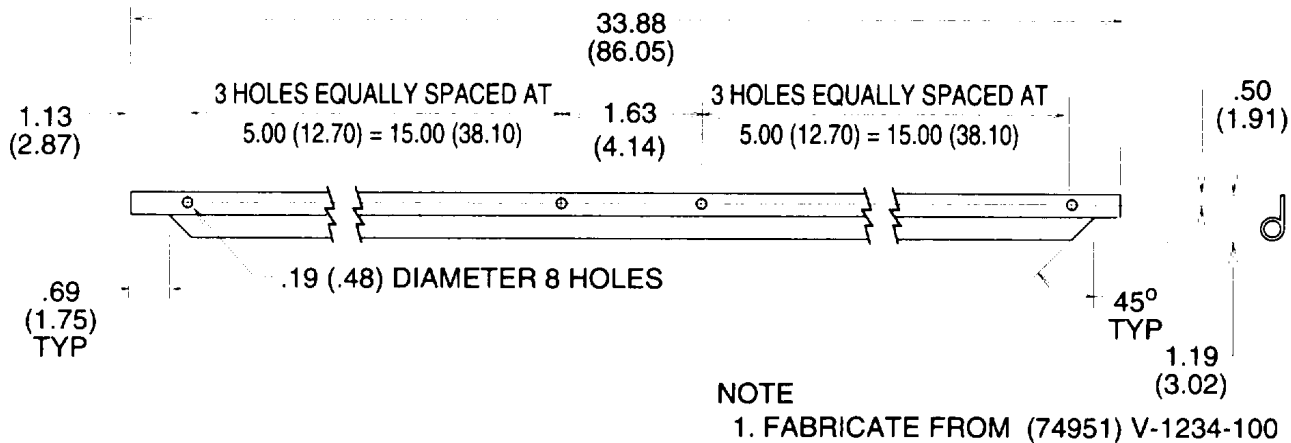

Figure F-12. Gasket, Top/Bottom, Part Number 148K0143

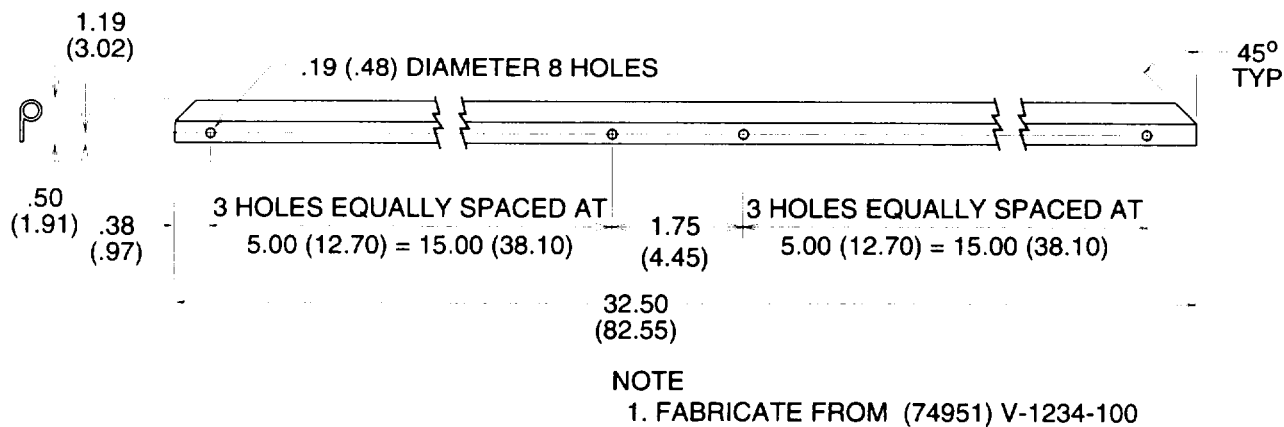
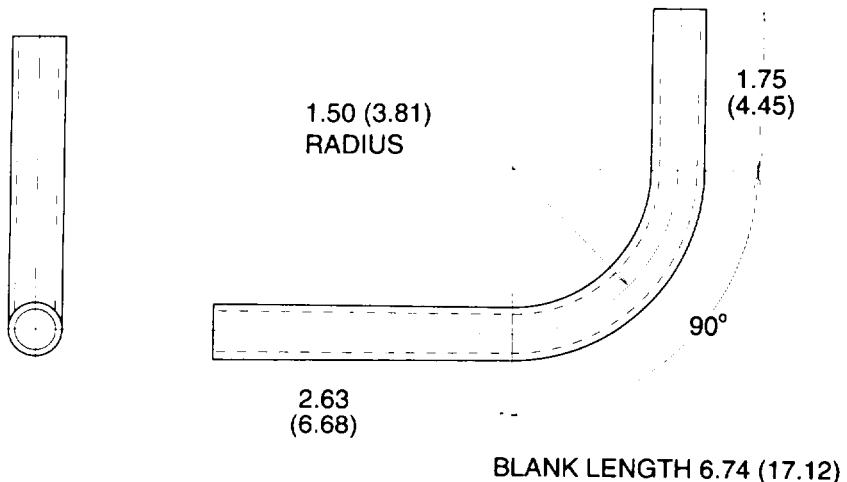
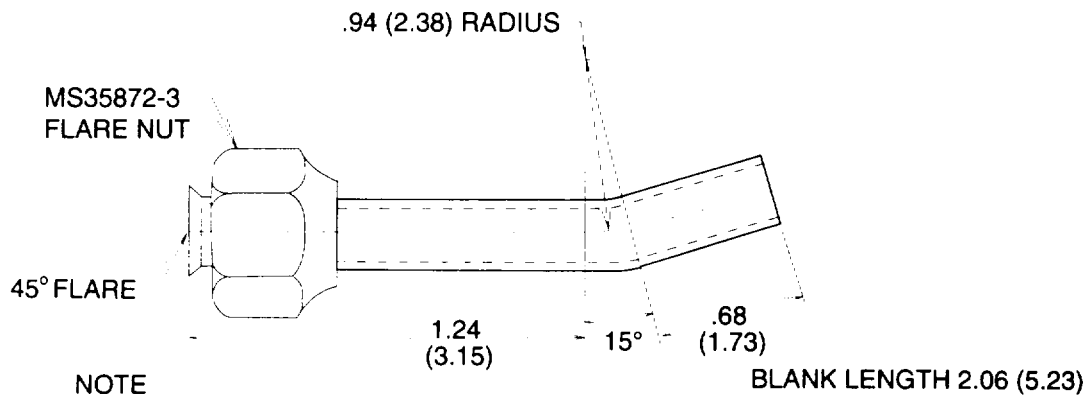

Figure F-13. Gasket, Right/Left, Part Number 148K0144



NOTE
 1. FABRICATE FROM .625 (1.58) O.D. X 0.035 (0.089)
 WALL ASTM B280 COPPER TUBING

Figure F-14. Tube, Coil To Heat Exchanger, Part Number 148K0168



NOTE
 1. FABRICATE FROM .375 (0.95) O.D. X 0.049 (0.12)
 WALL ASTM B280 COPPER TUBING

Figure F-15. Tube Expansion, Valve To Heat Exchanger, Part Number 148K0169-1/T

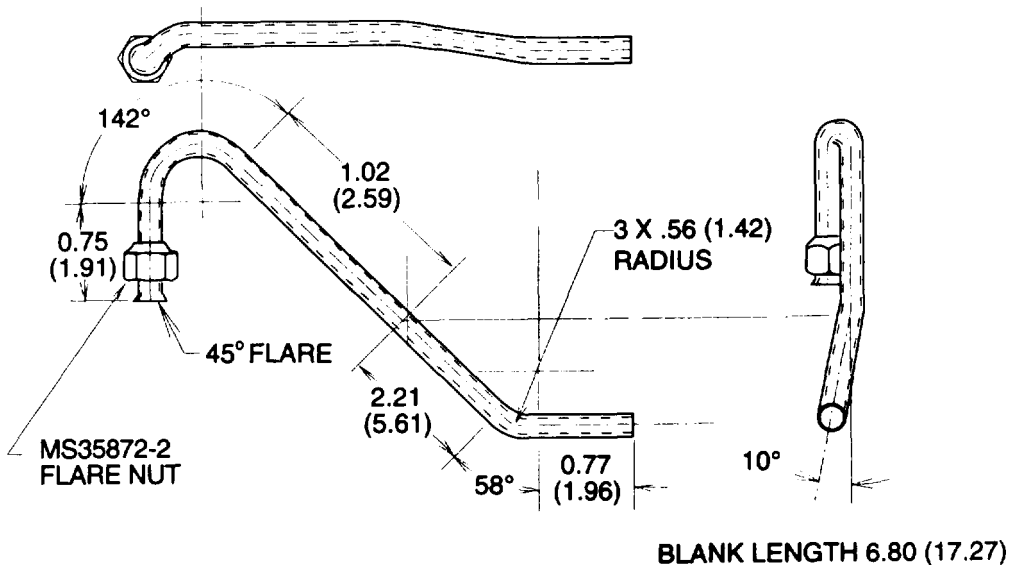

NOTE
 1. FABRICATE FROM .250 (.635) O.D. X 0.030 (0.076)
 WALL ASTM B280 COPPER TUBING

Figure F-16. Tube, Expansion Valve Bypass, Part Number 148K0171

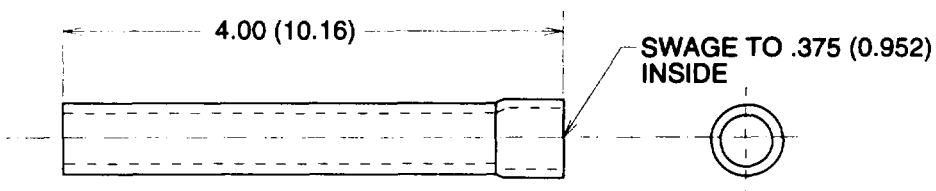

NOTE
 1. FABRICATE FROM .375 (0.952) O.D. X 0.032 (0.081)
 WALL ASTM B280 COPPER TUBING

Figure F-17. Tube, 0.375 Tee To Defrost Coil, Part Number 148K0173

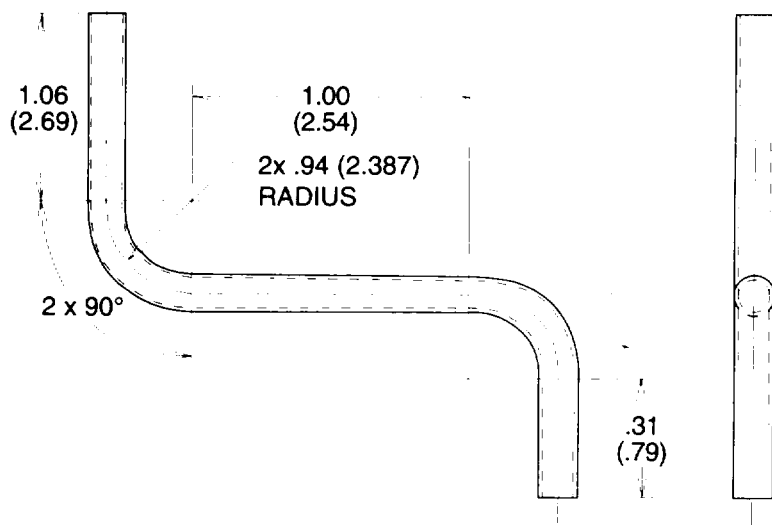

BLANK LENGTH 9.06 (23.00)

NOTE

1. FABRICATE FROM .38 (.965) O.D. X 0.032 (0.081) WALL ASTM B280 COPPER TUBING

Figure F-18. Tube, Heat Exchanger to 0.375 Elbow, Part Number 148K0174

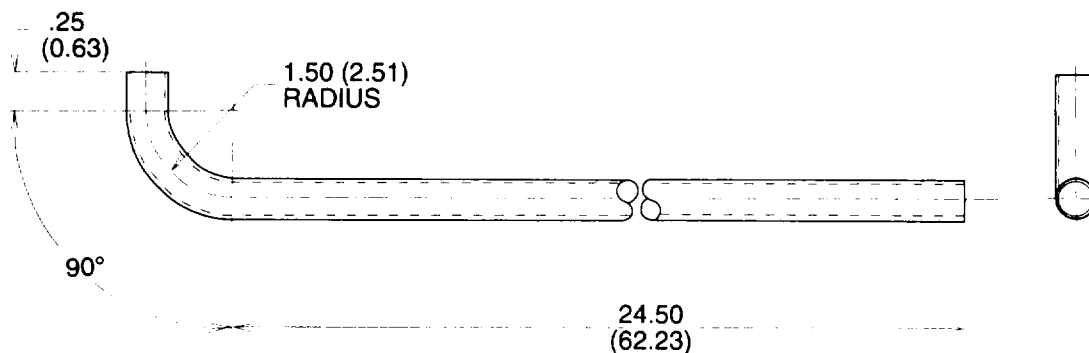

BLANK LENGTH 27.11 (68.85)

NOTE

1. FABRICATE FROM .625 (1.58) O.D. X 0.035 (0.81) WALL ASTM B280 COPPER TUBING

Figure F-19. Tube, Condenser Outlet, Part Number 148K0221

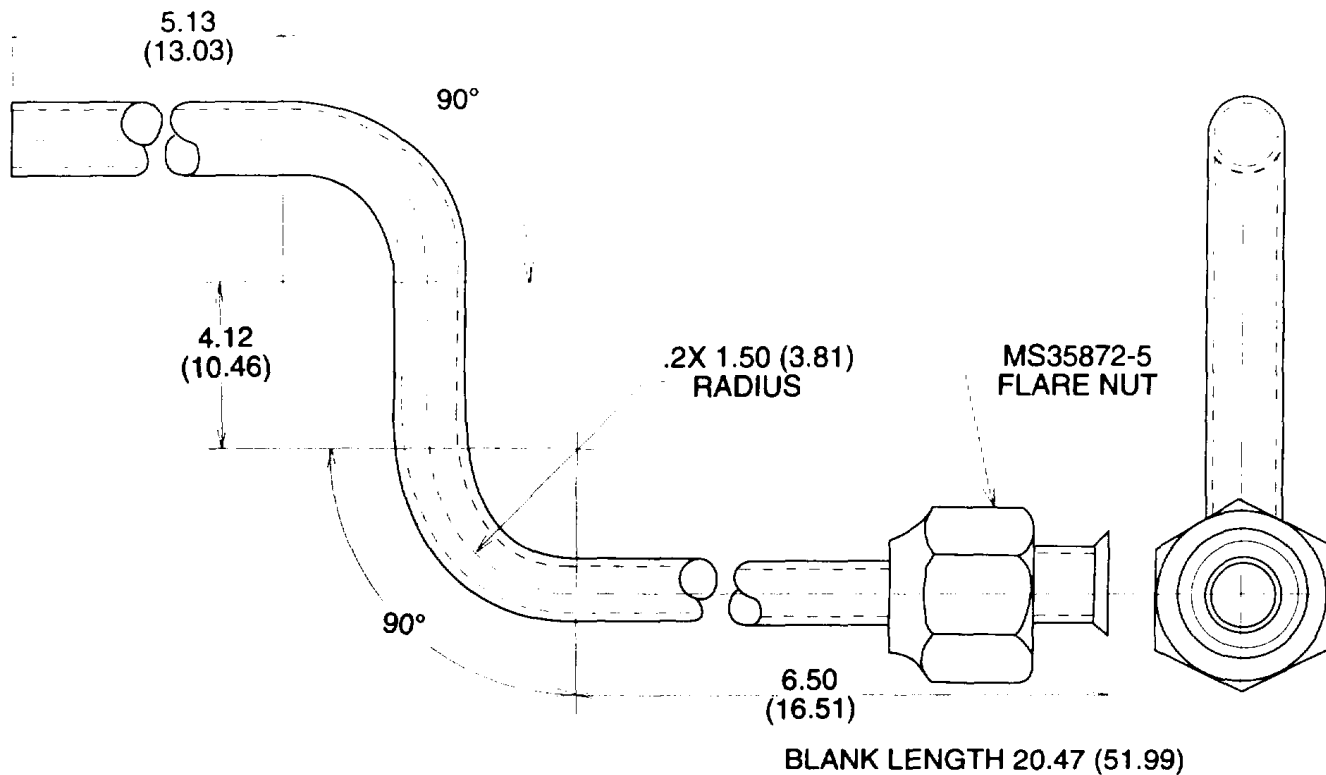

NOTE

1. FABRICATE FROM .625 (1.587) O.D. X 0.035 (0.088) WALL ASTM B280 COPPER TUBING

Figure F-20. Tube, Receiver Inlet, Part Number 148K0222-1/T

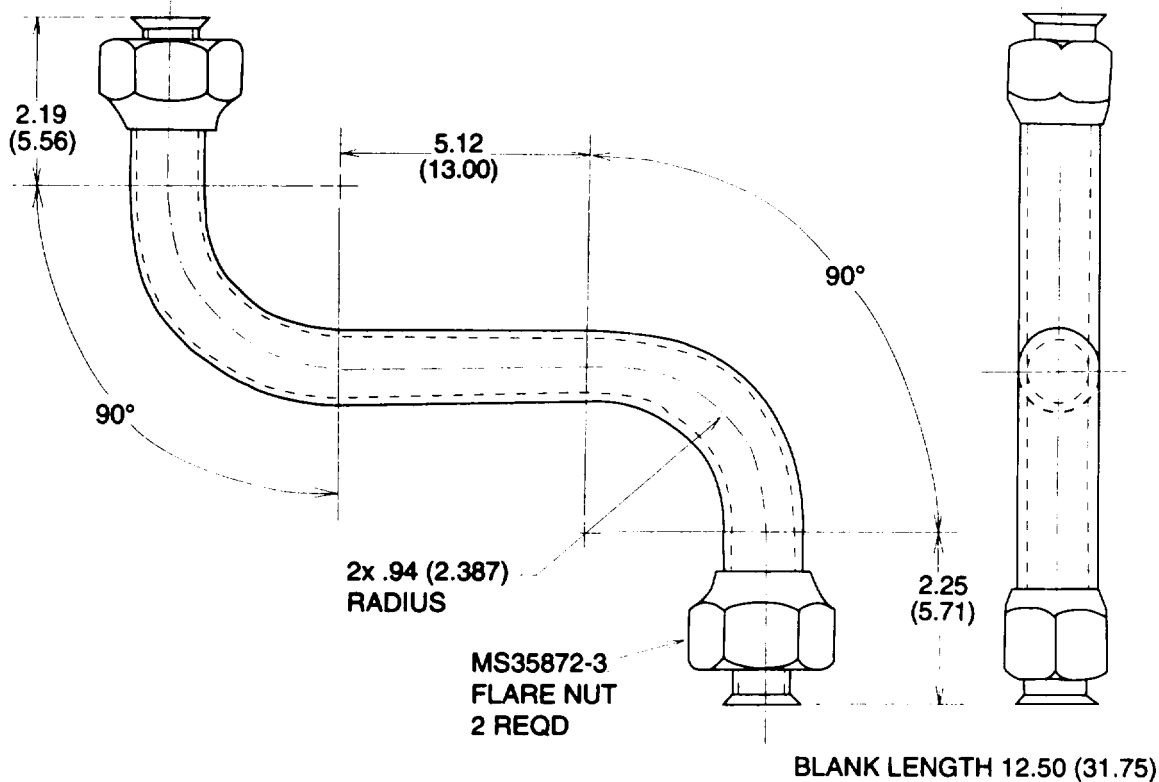

NOTE

1. FABRICATE FROM .375 (.952) O.D. X 0.032 (0.081) WALL ASTM B280 COPPER TUBING

Figure F-21. Tube, Receiver To Filter Drier, Part Number 148K0223-1-T

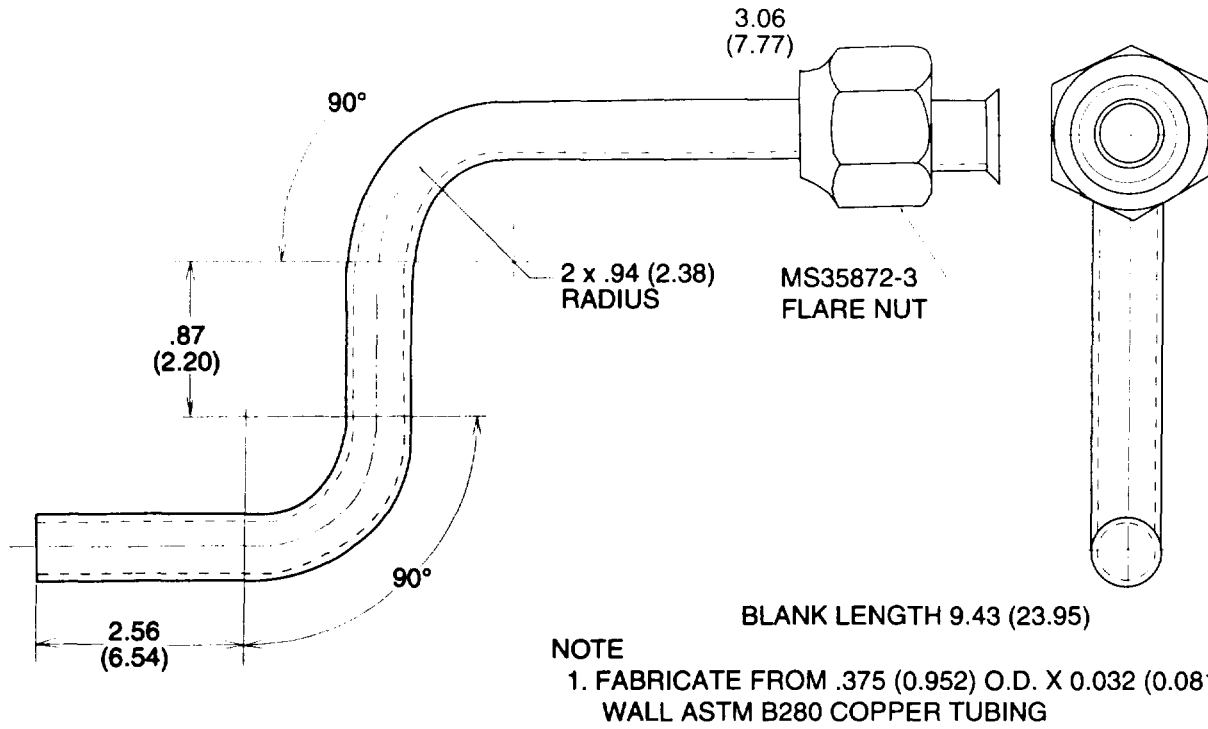

Figure F-22. Tube, Hand Valve To Solenoid N.C., Part Number 148K0224-1/T

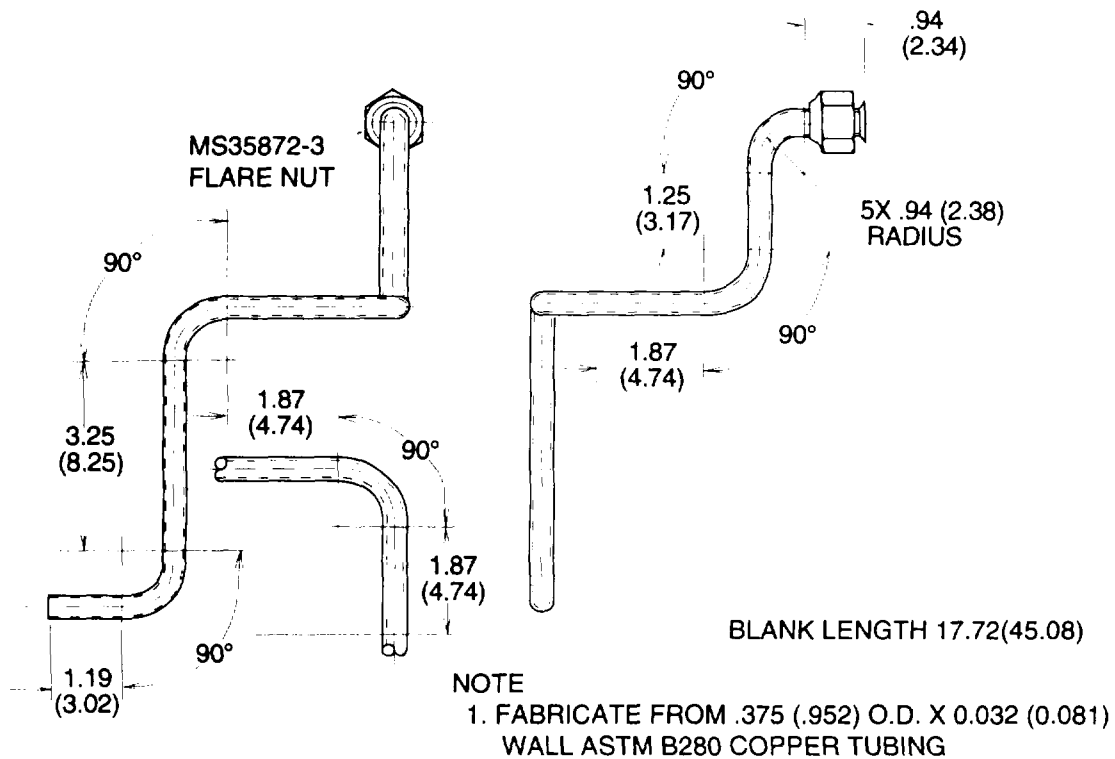
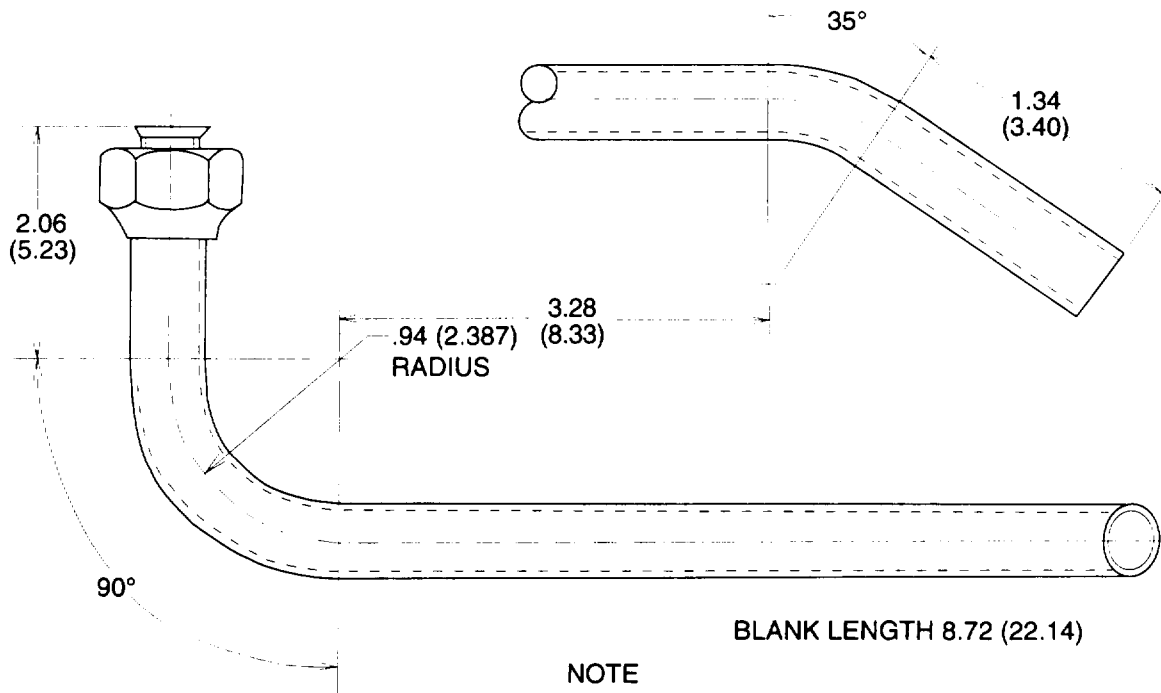

Figure F-23. Tube, Solenoid N. C. to Sight Glass, Part Number 148K0225-1/T



NOTE

1. FABRICATE FROM .375 (.952) O.D. X 0.032 (0.081) WALL ASTM B280 COPPER TUBING

Figure F-24. Tube, Sight Glass To Elbow, Part Number 148K0226-1/T

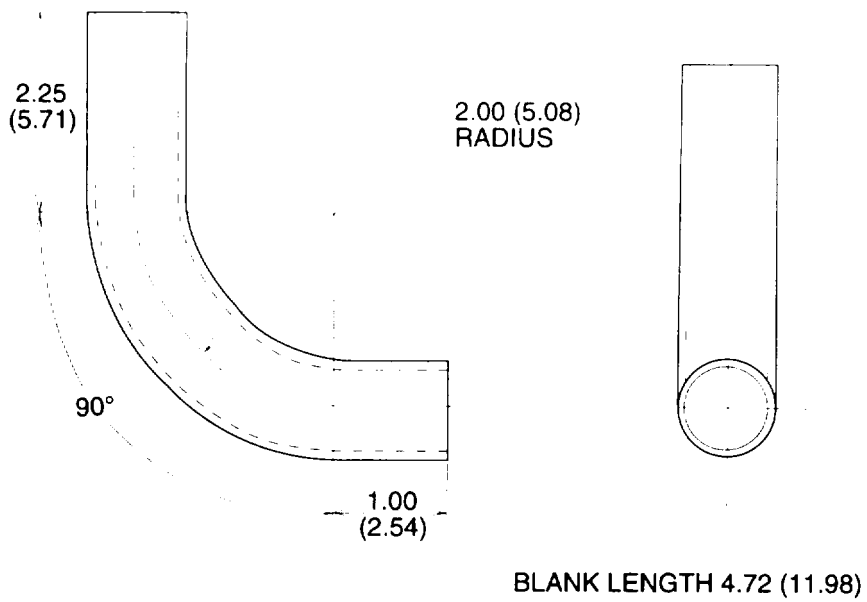

NOTE
 1. FABRICATE FROM .500 (1.27) O.D. X 0.032 (0.81) WALL ASTM B280 COPPER TUBING

Figure F-25. Tube, Compressor Discharge, Part Number 148K0227

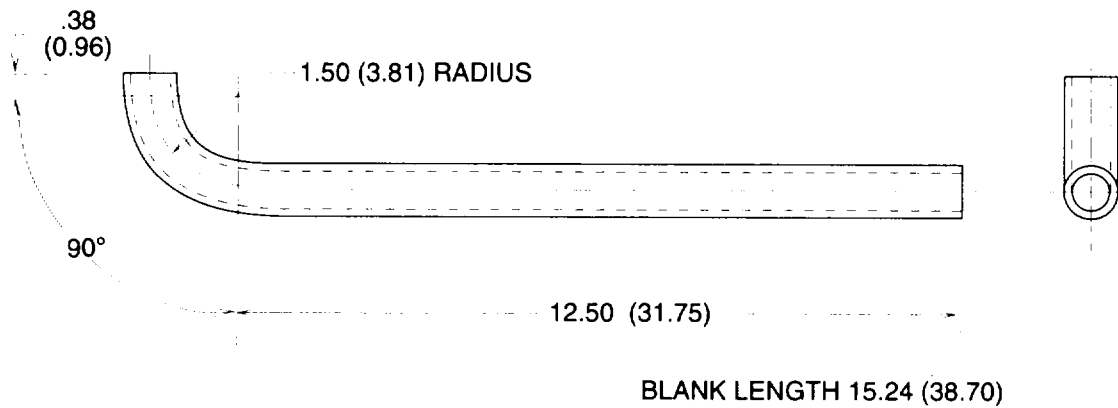

NOTE
 1. FABRICATE FROM .625 (1.58) O.D. X 0.035 (0.088) WALL ASTM B280 COPPER TUBING

Figure F-26. Tube, Isolator (Discharge) to Reducer Elbow, Part Number 148K0228

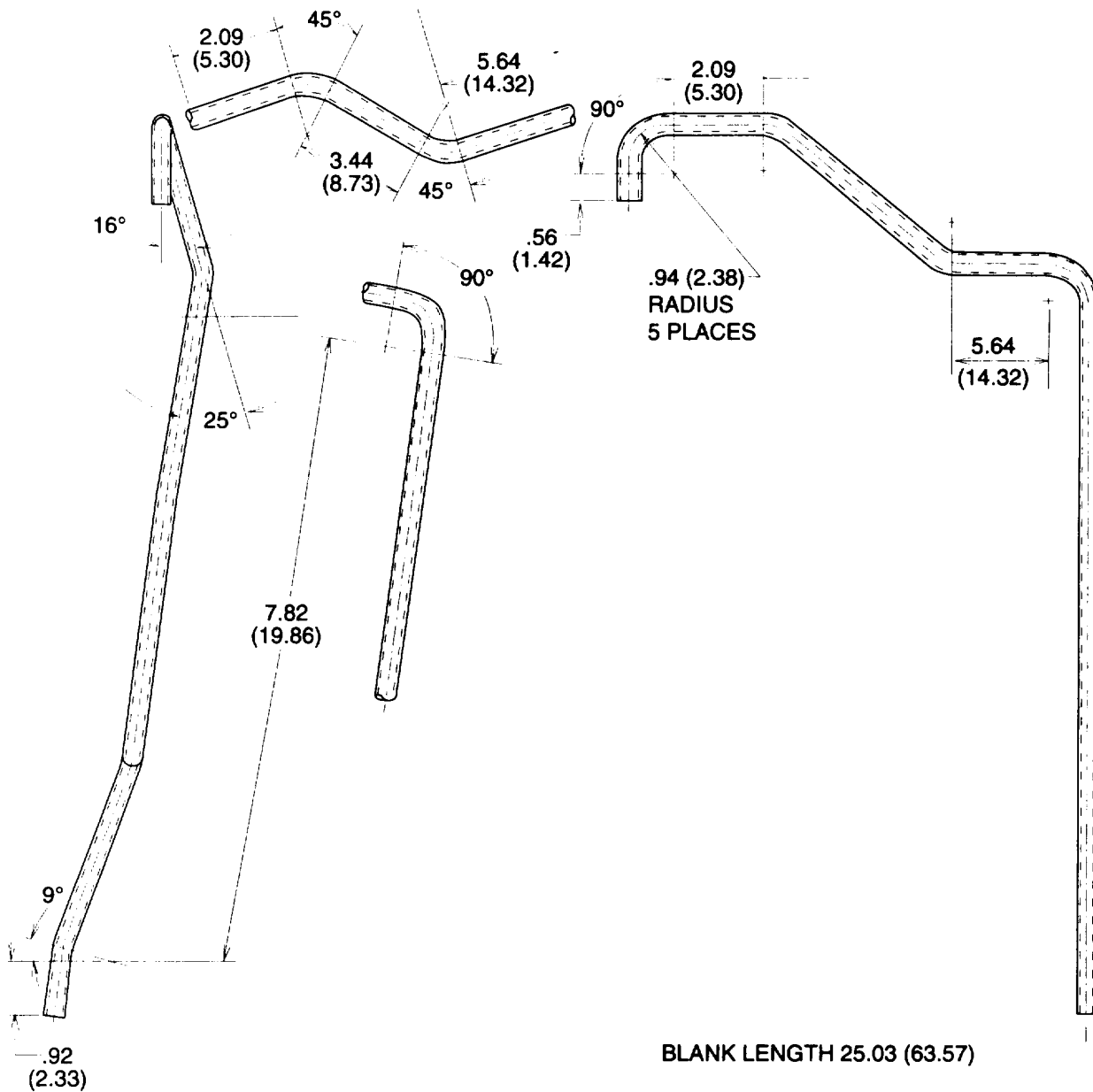

NOTE

1. FABRICATE FROM .375 (.952) O.D. X 0.032 (0.081) WALL ASTM B280 COPPER TUBING

Figure F-27. Tube, Strainer Hand Valve, Part Number 148K0229

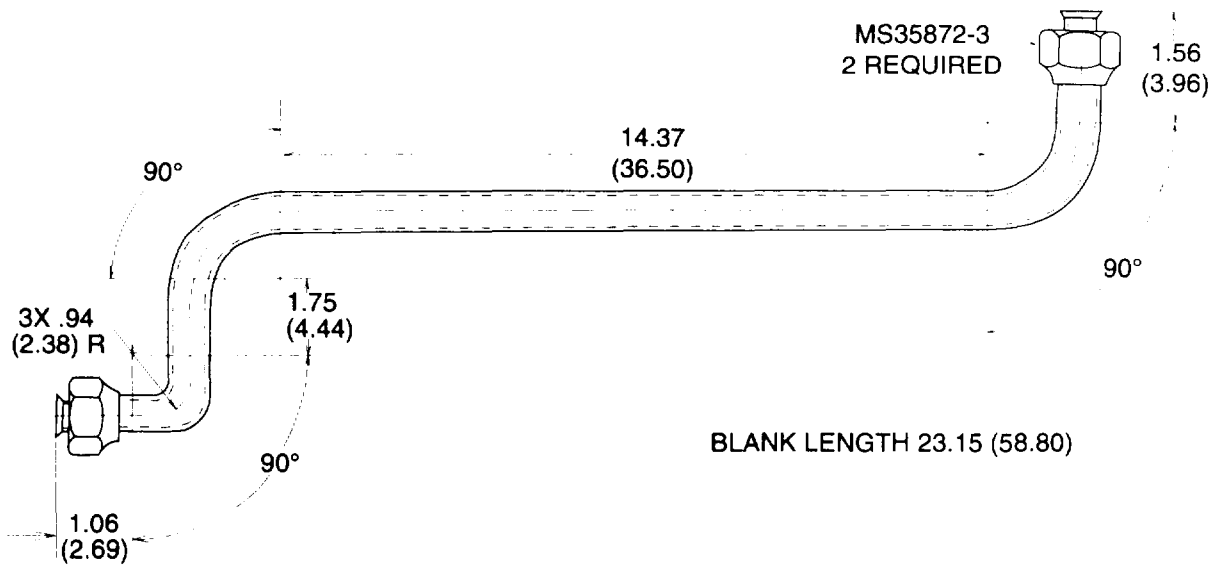

NOTE

- 1. FABRICATE FROM .375 (.952) O.D. X 0.032 (0.081) WALL ASTM B280 COPPER TUBING

Figure F-28. Tube, Strainer to Solenoid N.O., Part Number 148K0230-1/T

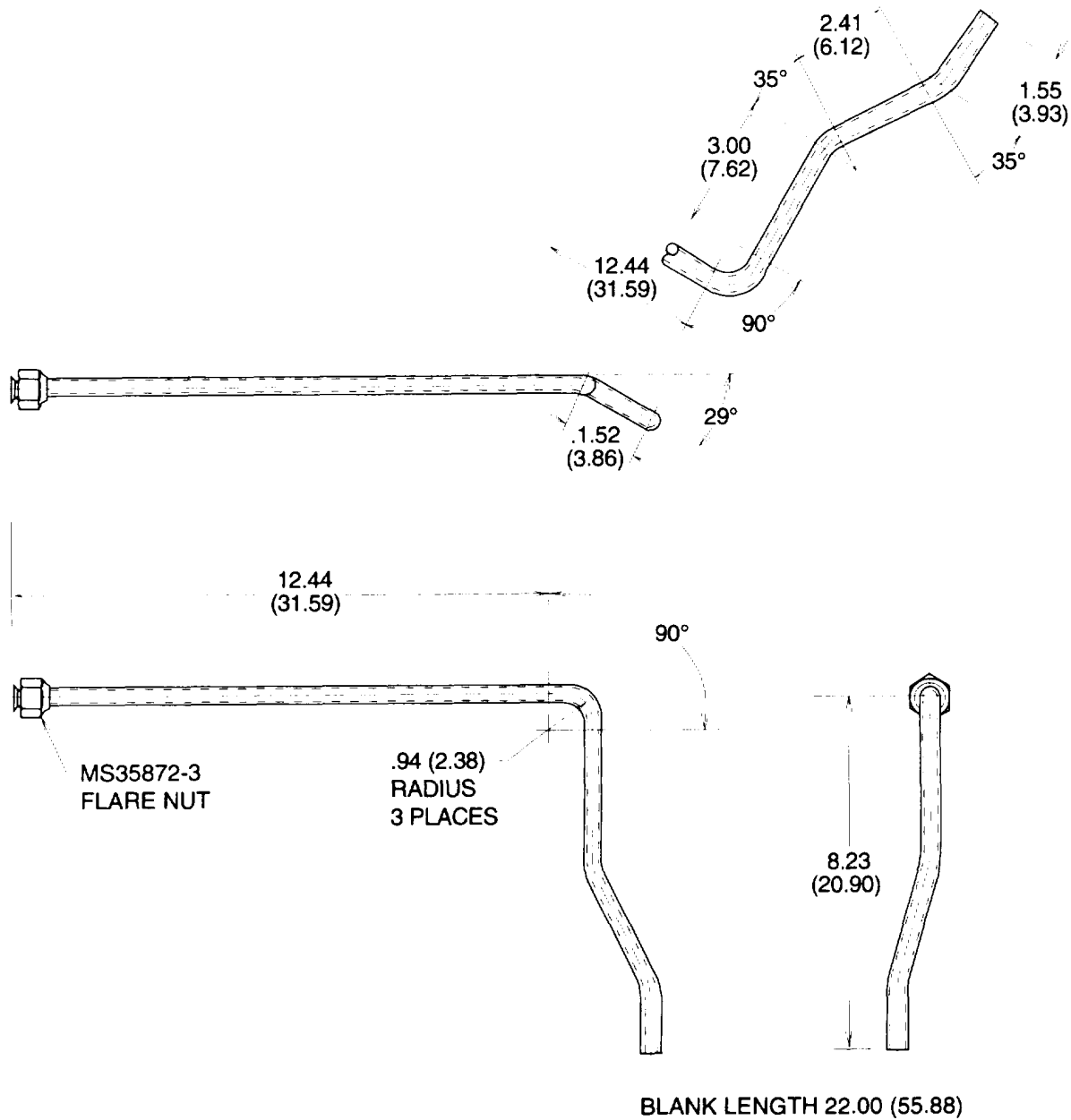

NOTE
 1. FABRICATE FROM .375 (.952) O.D. X 0.032 (0.081) WALL ASTM B280 COPPER TUBING

Figure F-29. Tube, Solenoid N. O. to Elbow, Part Number 149K0231-1/T

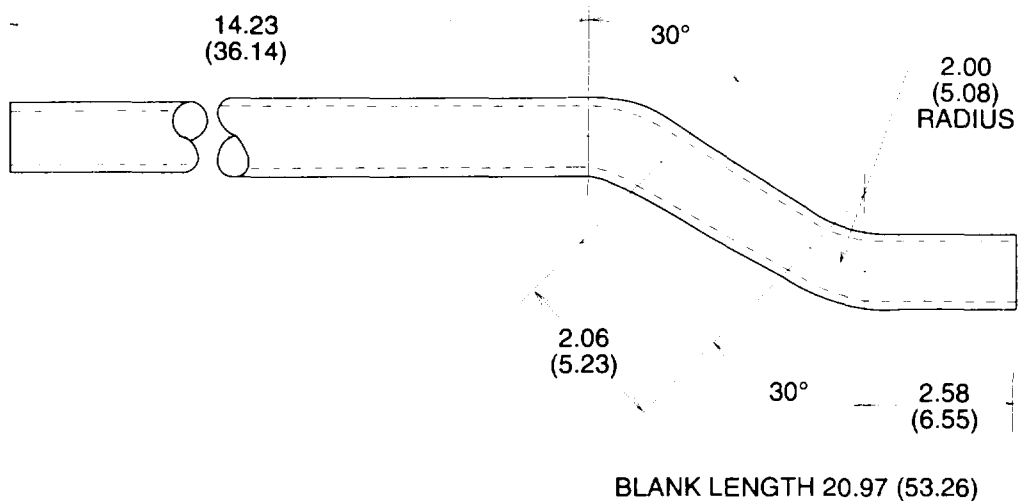

NOTE
 1. FABRICATE FROM .875 (2.222) O.D. X 0.045 (0.114) WALL ASTM B280 COPPER TUBING

Figure F-30. Tube, Isolator (Suction) To CPR Valve, Part Number 148K0232

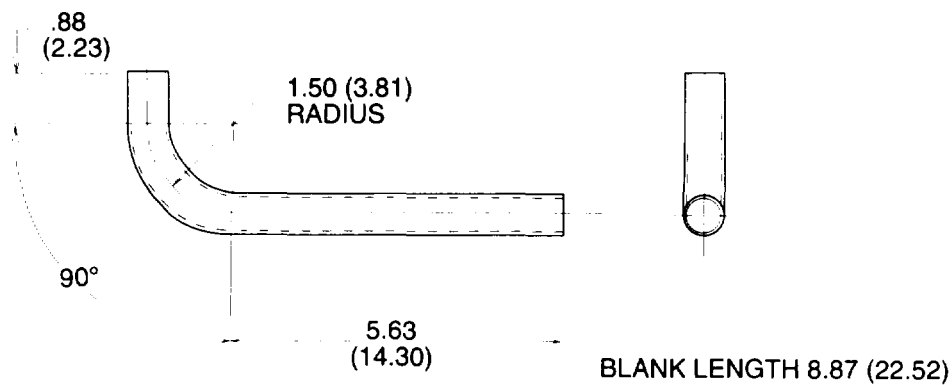

NOTE
 1. FABRICATE FROM .625 (1.58) O.D. X 0.032 (0.81) WALL ASTM B280 COPPER TUBING

Figure F-31. Tube, Discharge Pressure Regulator to Elbow, Part Number 148K0233

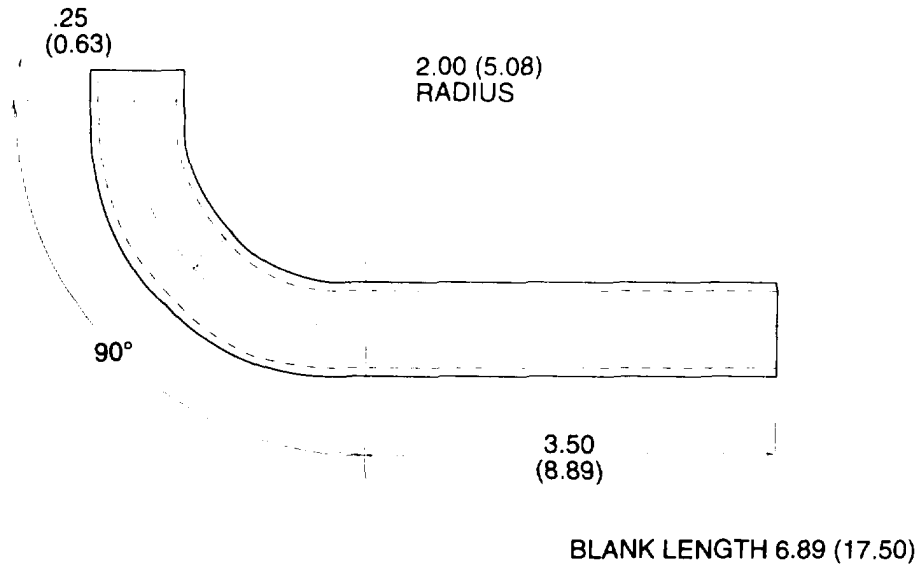

NOTE

1. FABRICATE FROM .875 (2.22) O.D. X 0.045 (2.54) WALL ASTM B280 COPPER TUBING

Figure F-32. Tube, DPR Valve To Street, Part Number 148K0234

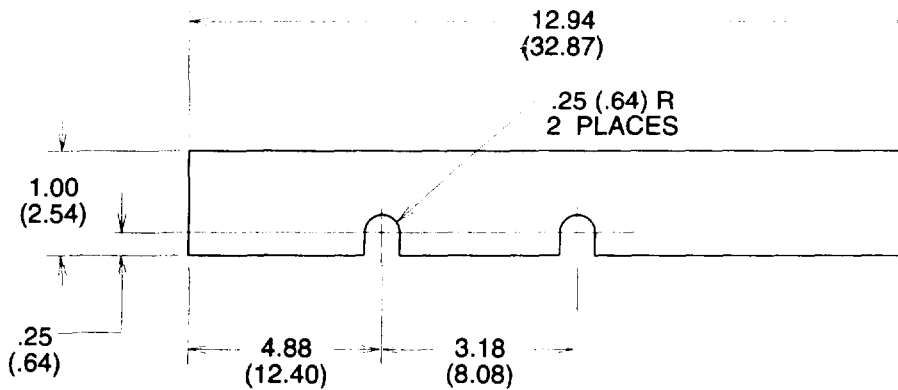

NOTE

1. FABRICATE FROM ASTM D735 0.063 (0.160) THICK NEOPRENE RUBBER

Figure F-33. Gasket, Horizontal, Part Number 148K0245

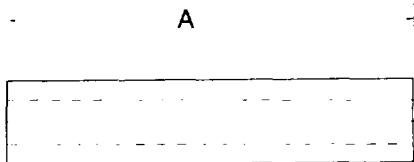

ITEM	PART NO.	DIM "A"
1	150K0163-1	8.00 (20.32)
2	150K0165-5	38.00 (96.52)
3	150K0165-7	28.00 (71.12)
4	150K0165-11	16.00 (40.64)
5	150K01 65-13	33.00 (83.82)

NOTE

1. FABRICATE FROM (24161) 70001 (OR EQUAL) .25 (.64) ID RUBBER HOSE

Figure F-34. Hose, Drain, Part Number 150K0165

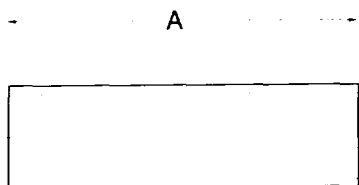

ITEM	PART NO.	DIM "A"
1	150K0185-1/1	18.00 (45.72)
2	150K0201-1/1	4.00 (10.16)

NOTE

1. FABRICATE FROM QQ-B-575/R30T281

Figure F-35. Braid, Wire, Tubular, Part Number 150K0185-1/1 and 150K0201-1/1

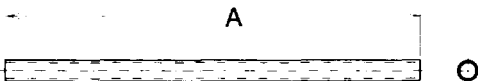

ITEM	PART NO.	DIM "A"
1	150K0206-3/3	60.00 (152.40)
2	150K0206-5/3	39.96 (101.50)

NOTE
 1. FABRICATE FROM .125 (.318) O.D. X 0.030 (0.076) WALL ASTM B280 COPPER TUBING

Figure F-36. Capillary Lines, Part Number 150K0206-3/3 & -5/3

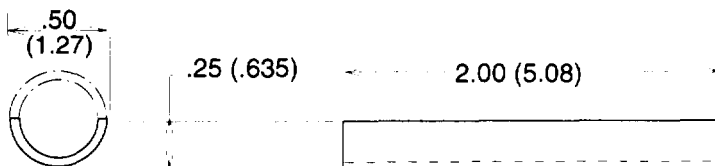

NOTE
 1. FABRICATE FROM 0.50 (1.27) X .032 (.0812) WALL ASTM B280 COPPER TUBING

Figure F-37. Contact Cradle, Sensing Bulb, Part Number 152K0194

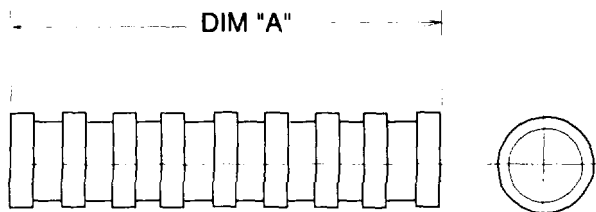

ITEM	PART NO.	DIM "A"
1	51206-13	13.00 (33.02)
2	51206-25	25.00 (63.50)
3	51206-30	30.00 (76.20) 1
4	51206-36	36.00 (91.44)

NOTE

1. FABRICATE FROM (1W654) PLS-1/2 (OR EQUAL) LOOM

Figure F-38. Loom-1/2 I. D. Part Number 51206-13, -25, -30, and -36

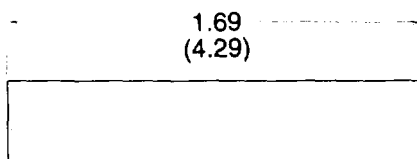

NOTE

1. FABRICATE FROM (70563) 1332 X 1.125 (2.858) WIDE

Figure F-39. Tape, Adhesive, Part Number 8337032-4

APPENDIX G

MANDATORY REPLACEMENT PARTS

Item Number	Nomenclature	Part Number	CAGEC
1	Lock Washer	500K1950-3	(94833)
2	Lock Washer	500K1950-4	(94833)
3	Self Locking Nut	500K1927-9	(94833)
4	Self Locking Nut	500K1927-3	(94833)
5	Lock Washer	500K1950-1	(94833)
6	Self Locking Nut	500K1927-1	(94833)
7	Self Locking Nut	500K1927-4	(94833)
8	Lock Washer	500K1950-6	(94833)
9	Self Locking Nut	500K1927-2	(94833)
10	Self Locking Nut	500K1927-6	(94833)
11	Gasket	774-5035	(62445)
12	Lock Washer	500K1950-5	(94833)
13	Washer	777-5428	(62445)
14	Washer	777-5401	(62445)
15	Gasket	774-5124	(62445)
16	Washer	777-5409	(62445)
17	Gasket	774-5131	(62445)
18	Washer	777-5439	(62445)
19	Washer	777-5450	(62445)
20	Washer	777-5402	(62445)
21	Washer	777-5407	(62445)
22	Lock Washer	500K1950-5	(94833)

Item Number	Nomenclature	Part Number	CAGEC
23	Rivet	500K2031-140	(94833)
24	Nut	61X4	(79470)
25	Ferrule Tube	60X4	(79470)
26	Connector	4750-4B	(00624)
27	Rivet	500K2031-139	(94833)
28	Teflon Seal	24591	(97765)
29	Self Locking Nut	500K1927-5	(94833)
30	Self Locking Nut	500K1927-8	(94833)
31	Gasket	774-5062	(62445)
32	Lock Washer	500K1950-2	(94833)
33	Rivet	13214E3789-6	(97403)
34	Lock Washer	17-10715	(10855)
35	Discharge Valves	17-40086	(10855)
36	Suction Valves	17-44111-00	(10855)
37	Gasket Service Valve	17-21003	(10855)
38	Gasket Service Valve	17-10811-05	(10855)
39	Suction Valve Position Spring	17-40083	(10855)
40	Valve Plate Gasket	17-50002	(10855)
41	Discharge Valve Stop	17-40087	(10855)
42	Gasket	17-44123-00	(10855)
43	Gasket	17-10218-02	(10855)
44	Gasket	17-44713-00	(10855)
45	Rivet	SSPQ-64	(05693)
46	Washer	777-7197	(62445)

Item Number	Nomenclature	Part Number	CAGEC
47	Washer	777-5435	(62445)
48	Gasket (0.2)	774-5075	(62445)
49	Gasket (0.2)	774-5066	(62445)
50	Gasket	774-5134	(62445)
51	Gasket	774-5115	(62445)
52	Gasket	774-5164	(62445)
53	Gasket	774-5173	(62445)
54	Gasket (0.1)	774-5067	(62445)
55	Gasket		(62445)
56	O-Ring	775-7912	(62445)
57	O-Ring	775-7949	(62445)
58	Rivet	SSPV-64	(05693)
59	Rivet	MS20605S6W2	(96096)
60	Gasket (0.3)	774-5065	(62445)
61	Gasket (0.1)	774-5076	(62445)

G-31(G-4 blank)

ALPHABETICAL INDEX

A

Access Panel Repair..... 5-3
 Access Panel Replacement..... 4-16
 Accumulator Replacement..... 5-29
 Administrative Storage..... 4-69
 Air Cleaner Replacement..... 4-50
 Air Handling System..... 1-15
 Alternator Replacement..... 5-48
 Alternator Testing..... 4-58
 Ammeter M1 Testing and Replacement..... 4-27
 Assembly and Preparation for Use..... 2-4

B

Barrel Bolt Replacement..... 4-17
 Battery BT Testing and Replacement..... 4-35
 Battery Shield Repair..... 5-5
 Brazing/Debrazing Procedure..... 5-12

C

Charging the Refrigerant System..... 5-15
 Check Valve Replacement..... 5-26
 Circuit Breaker CB1 Testing
 and Replacement..... 4-21
 Cleaning..... 3-4
 Common Tools and Equipment..... 4-1
 Compound Gage Replacement..... 5-18
 Compressor B1 Testing, Service, Repair,
 and Replacement..... 5-40
 Compressor Pulley Replacement..... 5-6
 Condenser Coil Replacement..... 5-23
 Condenser Fan Replacement..... 4-41
 Continuous Duty Solenoid K5 Testing
 and Replacement..... 4-34
 Control Box Assembly Replacement..... 4-20
 Control Box Cover Repair
 and Replacement..... 5-2
 Control Panel Repair..... 5-4
 Control Relays K1, K2 and K3 Testing
 and Replacement..... 4-24
 Control Transformer T1 Testing
 and Replacement..... 4-32
 Corrosion Prevention and Control..... 1-9
 Cylinder Head Testing, Replacement,
 and Adjustment..... 5-45

D

Decals and Instruction Plates..... 2-8

Defrost Timer TM1 Testing and Replacement 4-29

Dehydrator Replacement..... 5-17

Destruction of Army Material to Prevent Enemy Use..... 1-3

Differential Oil Pressure Switch S5 Replacement 5-35

Discharging the Refrigerant System..... 5-10

Dual Pressure Control Switch S2 Replacement 5-36

E

Engine and Compressor Base Replacement..... 5-49

Engine Drain Hose Replacement..... 4-60

Engine Oil Pressure Switch Testing and Replacement 4-52

Engine Oil Pump Inspection and Replacement 5-46

Engine Pulley Replacement..... 4-39

Engine Repair and Replacement..... 4-61

Engine Speed Switch S8 replacement..... 4-31

Engine Temperature Switch Testing and Replacement 4-53

Equipment Characteristics, Capabilities and Features..... 1-10

Equipment Data 1-12

Evacuating the Refrigerant System..... 5-14

Evaporator Coil Replacement 5-39

Evaporator Cover Panel Replacement..... 4-15

Evaporator Fan Replacement..... 4-42

Expansion Valve Replacement..... 5-38

F

Fan Clutch C1 Testing and Replacement..... 4-46

Fan Drive Shaft Replacement..... 5-7

Fault Controls and Indicators..... 2-2

Flange Bearing (Condenser Fan) Replacement 4-43

Flange Bearing (Evaporator Fan) Replacement 4-44

Flywheel Replacement..... 5-47

Front Coil Guard Panel Replacement..... 4-14

Front Door Repair 5-51

Fuel Filter Replacement..... 4-56

Fuel Gage Replacement 4-65

Fuel Pump Replacement..... 5-44

Fuel Return Hoses Replacement..... 4-63

Fuel Solenoid Testing and Replacement 4-54

Fuel Supply Hoses/Fuel Pipe Repair and Replacement..... 4-62

Fuel Tank Repair and Replacement..... 4-67

Fuses F1 and F2 Testing and Replacement 4-23

G

Gasket (Heat Shield) Replacement..... 4-68

General..... 2-3, 3-3, 4-10, 6-1

Glow Plug Testing and Replacement..... 4-59

Grease Fitting Extension Replacement..... 4-45

H

Heat Exchanger Replacement..... 5-37

Hourmeter M2 Testing and Replacement..... 4-26

Housing Repair 5-52, 6-2

I

Idler Pulley Replacement 4-40
 In-Line Fuel Filter Replacement 4-64
 Injection Pump Testing, Replacement,
 and Adjustment..... 5-43
 Installation Instructions..... 4-6
 Isolation Valves Replacement..... 5-21

L

Lamp Assembly DS1 Testing
 and Replacement..... 4-22
 Leak Testing the Refrigerant System..... 5-13
 Location and Description of
 Major Components..... 1-11
 Long Term Storage or Shipment..... 4-70
 Lubrication 3-1, 4-9

M

Maintenance Forms, Records and Reports..... 1-2
 Mandatory Replacement Parts..... 4-11
 Metal Hose Assembly (Discharge)
 Replacement 5-27
 Metal Hose Assembly (Suction)
 Replacement 5-28
 Muffler Replacement..... 4-51

N

NBC Decontamination Procedures..... 2-10
 Nozzle Testing and
 Replacement 5-42

O

Official Nomenclature, Names
 and Designations..... 1-6
 Oil Filter Replacement 4-49
 Operating Controls and Indicators..... 2-1
 Operating System 1-13
 Operation Under Inclement Weather..... 2-9
 Operator Checks..... 2-6

P

Preliminary Adjustment of Equipment 4-8
 Preliminary Servicing of Equipment 4-7
 Preparation for Storage or Shipment..... 1-4
 Pressure Gage Replacement..... 5-19
 Pressure Regulator Valve (Crankcase)
 Replacement 5-25
 Pressure Regulator Valve (Discharge)
 Replacement 5-24
 Purging the Refrigerant System 5-11
 Push Switches S9 and S10 Testing
 and Replacement..... 4-37
 Push Switches S9 and S10 Testing
 and Replacement..... 4-37

Q

Quality Assurance..... 1-5

R

Receiver Replacement..... 5-22
 Refrigerant System Pressure Check..... 5-16
 Refrigeration System..... 1-14
 Refrigeration System Repairs..... 5-8
 Remote Bulb Thermostat S2 Testing
 and Replacement..... 4-30
 Repair Parts..... 4-3
 Reporting Equipment Improvement
 Recommendations (EIR)..... 1-7

S

Scope 1-1
 Sending Unit Replacement..... 4-66
 Service Manifold Installation 5-9
 Service Upon Receipt of Material..... 4-5
 Shutdown Procedures..... 2-7
 Side Doors Replacement..... 5-50
 Sight Indicator Replacement..... 5-34
 Site and Shelter Requirements..... 4-4
 Solenoid Valve L1 (Liquid Line)
 Replacement 5-30
 Solenoid Valve L1 (Liquid Line) Testing
 and Repair..... 4-47
 Solenoid Valve L2 (Defrost Line)
 Replacement 5-31
 Solenoid Valve L2 (Defrost Line) Testing
 and Repair..... 4-48
 Special Tools, TMDE,
 and Support Equipment..... 4-2
 Starting Motor Replacement..... 4-55
 Startup Procedures..... 2-22
 Stop Valve (Defrost Line) Replacement..... 5-33
 Stop Valve (Liquid Line) Replacement..... 5-32
 Strainer Replacement 5-20

T

Temperature Switch S3 Replacement..... 4-36
 Thermometer Testing and Replacement..... 4-33
 Time Delay Relays TD1 and TD2 Testing
 and Replacement..... 4-25
 Toggle Switch S1 Testing and
 Replacement 4-28
 Top Access Panel Replacement..... 4-13
 Troubleshooting 3-2, 4-12, 5-1
 Tubing and Fittings Testing,
 Repair, and Replacement 5-41

U

Unit Mounting Bolt Assembly Replacement..... 4-18

V

V-Belts Replacement and Adjustment..... 4-38
 Voltage Regulator Replacement..... 4-57

W

Warranty Information 1-8
 Wires, Cables, and Harnesses Testing,
 Repair, and Replacement 4-19

By Order of the Secretary of the Army:

Official:

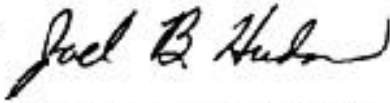

*Administrative Assistant to the
Secretary of the Army*
03094

DENNIS J. REIMER
General, United States Army
Chief of Staff

DISTRIBUTION:

To be distributed in accordance with DA Form 12-25E, block no. 6311, requirements for **TM 9-4110-255-14**

★US GOVERNMENT PRINTING OFFICE: 1997-554-121/60004

These are the instructions for sending an electronic 2028:

The following format must be used if submitting an electronic 2028. The subject line must be exactly the same and all fields must be included; however only the following fields are mandatory: 1,3, 4, 5, 6, 7, 8, 9,10,13,15, 16,17, and 27.

From: "Whomever" <whomever@avma27.army.mil>
To: mpmt@avma28.army.mil@st-louis-emh.army. mil
Subject: DA Form 2028

1. **From:** Joe Smith
2. **Unit:** home
3. **Address:** 4300 Park
4. **City:** Hometown
5. **St:** MO
6. **Zip:** 77777
7. **Date Sent:** 19-OCT-93
8. **Pub no:** 55-2840-229-23
9. **Pub Title:** TM
10. **Publication Date:** 04-JUL-85
11. **Change Number:** 7
12. **Submitter Rank:** MSG
13. **Submitter FName:** Joe
14. **Submitter MName:** T
15. **Submitter LName:** Smith
16. **Submitter Phone:** 123-123-1234
17. **Problem:** 1
18. **Page:** 2
19. **Paragraph:** 3
20. **Line:** 4
21. **NSN:** 5
22. **Reference:** 6
23. **Figure:** 7
24. **Table:** 8
25. **Item:** 9
26. **Total:** 123
27. **Text:**

This is the text for the problem below line 27.

RECOMMENDED CHANGES TO EQUIPMENT TECHNICAL PUBLICATIONS

 <p style="font-size: small; margin: 0;"><i>THEN...JOT DOWN THE DOPE ABOUT IT ON THIS FORM. CAREFULLY TEAR IT OUT, FOLD IT AND DROP IT IN THE MAIL.</i></p>		SOMETHING WRONG WITH PUBLICATION	
		FROM: (PRINT YOUR UNIT'S COMPLETE ADDRESS)	
		DATE SENT	
PUBLICATION NUMBER		PUBLICATION DATE	PUBLICATION TITLE
IN THIS SPACE, TELL WHAT IS WRONG AND WHAT SHOULD BE DONE ABOUT IT.			
BE EXACT PIN-POINT WHERE IT IS			
PAGE NO.	PARA-GRAPH	FIGURE NO.	TABLE NO.
PRINTED NAME, GRADE OR TITLE AND TELEPHONE NUMBER		SIGN HERE	

The Metric System and Equivalents

Linear Measure

1 centimeter = 10 millimeters = .39 inch
 1 decimeter = 10 centimeters = 3.94 inches
 1 meter = 10 decimeters = 39.37 inches
 1 dekameter = 10 meters = 32.8 feet
 1 hectometer = 10 dekameters = 328.08 feet
 1 kilometer = 10 hectometers = 3,280.8 feet

Weights

1 centigram = 10 milligrams = .15 grain
 1 decigram = 10 centigrams = 1.54 grains
 1 gram = 10 decigrams = .035 ounce
 1 decagram = 10 grams = .35 ounce
 1 hectogram = 10 decagrams = 3.52 ounces
 1 kilogram = 10 hectograms = 2.2 pounds
 1 quintal = 100 kilograms = 220.46 pounds
 1 metric ton = 10 quintals = 1.1 short tons

Liquid Measure

1 centiliter = 10 milliliters = .34 fl. ounce
 1 deciliter = 10 centiliters = 3.38 fl. ounces
 1 liter = 10 deciliters = 33.81 fl. ounces
 1 dekaliter = 10 liters = 2.64 gallons
 1 hectoliter = 10 dekaliters = 26.42 gallons
 1 kiloliter = 10 hectoliters = 264.18 gallons

Square Measure

1 sq. centimeter = 100 sq. millimeters = .155 sq. inch
 1 sq. decimeter = 100 sq. centimeters = 15.5 sq. inches
 1 sq. meter (centare) = 100 sq. decimeters = 10.76 sq. feet
 1 sq. dekameter (are) = 100 sq. meters = 1,076.4 sq. feet
 1 sq. hectometer (hectare) = 100 sq. dekameters = 2.47 acres
 1 sq. kilometer = 100 sq. hectometers = .386 sq. mile

Cubic Measure

1 cu. centimeter = 1000 cu. millimeters = .06 cu. inch
 1 cu. decimeter = 1000 cu. centimeters = 61.02 cu. inches
 1 cu. meter = 1000 cu. decimeters = 35.31 cu. feet

Approximate Conversion Factors

<i>To change</i>	<i>To</i>	<i>Multiply by</i>	<i>To change</i>	<i>To</i>	<i>Multiply by</i>
inches	centimeters	2.540	ounce-inches	Newton-meters	.007062
feet	meters	.305	centimeters	inches	.394
yards	meters	.914	meters	feet	3.280
miles	kilometers	1.609	meters	yards	1.094
square inches	square centimeters	6.451	kilometers	miles	.621
square feet	square meters	.093	square centimeters	square inches	.155
square yards	square meters	.836	square meters	square feet	10.764
square miles	square kilometers	2.590	square meters	square yards	1.196
acres	square hectometers	.405	square kilometers	square miles	.386
cubic feet	cubic meters	.028	square hectometers	acres	2.471
cubic yards	cubic meters	.765	cubic meters	cubic feet	35.315
fluid ounces	milliliters	29.573	cubic meters	cubic yards	1.308
pints	liters	.473	milliliters	fluid ounces	.034
quarts	liters	.946	liters	pints	2.113
gallons	liters	3.785	liters	quarts	1.057
ounces	grams	28.349	liters	gallons	.264
pounds	kilograms	.454	grams	ounces	.035
short tons	metric tons	.907	kilograms	pounds	2.205
pound-feet	Newton-meters	1.356	metric tons	short tons	1.102
pound-inches	Newton-meters	.11296			

Temperature (Exact)

°F	Fahrenheit temperature	5/9 (after subtracting 32)	Celsius temperature	°C
----	------------------------	----------------------------	---------------------	----

